

Chilled Water Fan Coil Units Air Handling Units

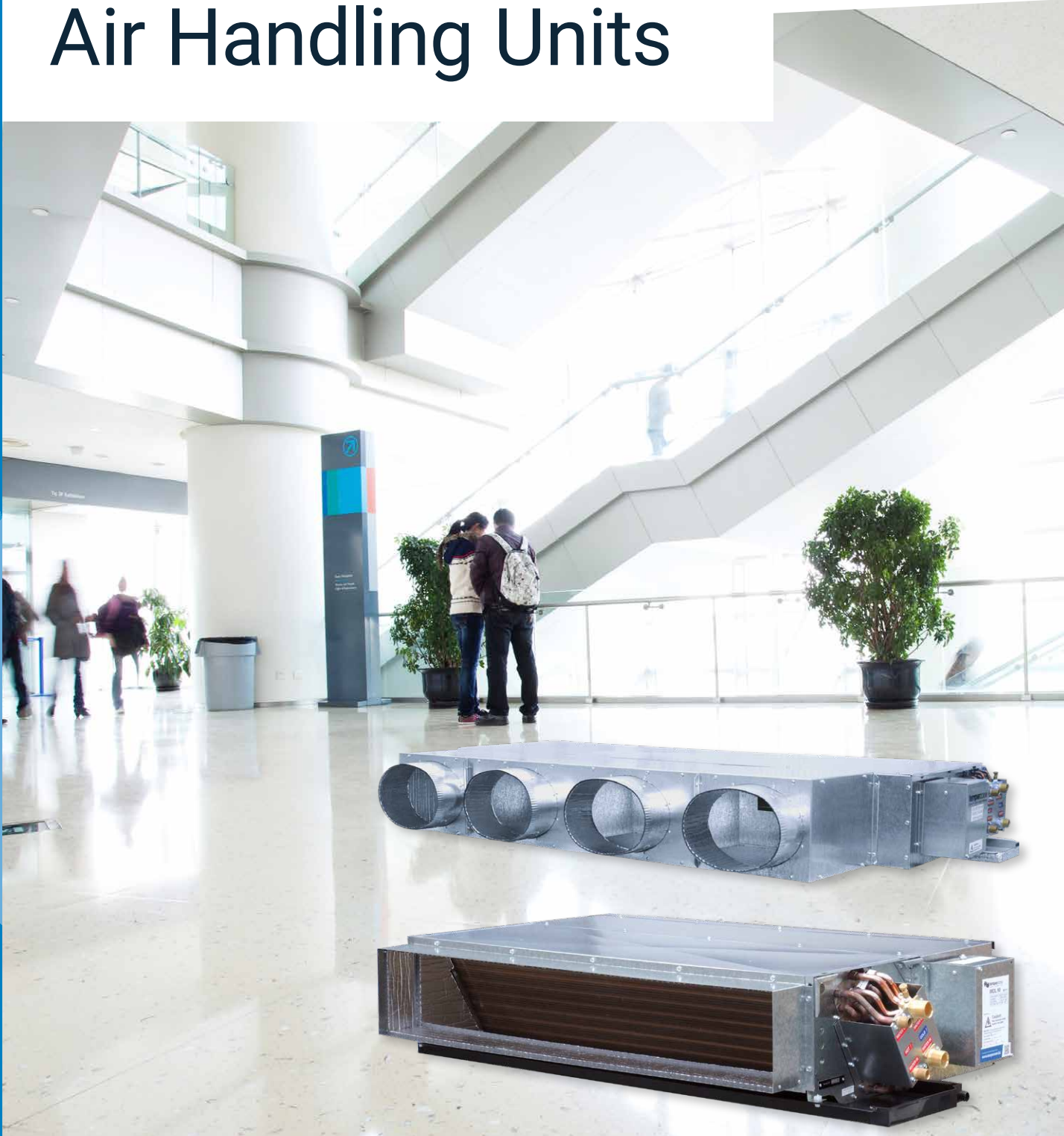



**Chilled water
solutions for
every project**

Index



Advantage range (underceiling)
(GMW)

05



Elementary range (low profile)
(MKT)

17



Advantage range (low profile)
(IMDL)

37



Premium range (low profile)
(IMDL-Y)

47

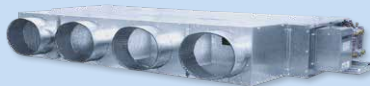

Premium range (Multizone)
(IXDL)

57



Advantage range (Compact FCU)
(IMD)

71



Premium range (Compact FCU)
(IMD-Y)

87



Advantage range (AHU)
(IJD)

103

OPTIONS

How we combine superior performance and energy savings

In a complex world of chilled water technology, Temperzone offer a wide range of solutions.

Temperzone has an extensive range of chilled water products, we have the product to suit your air movement requirements.

All models can be air flow controlled to match the required load profile either through simple local control or through a building management system.

The premium range incorporates EC fan technology, offering a higher efficiency operation compared to traditional AC alternatives.

All Temperzone units incorporate high efficiency heat transfer coils to extract the most out of your chilled water system. Temperzone units have a range of heat transfer coil options adaptable to a wide spectrum of chilled water system operating parameters. Whatever the water temperature and flow rate requirements, Temperzone has a solution to match your needs.

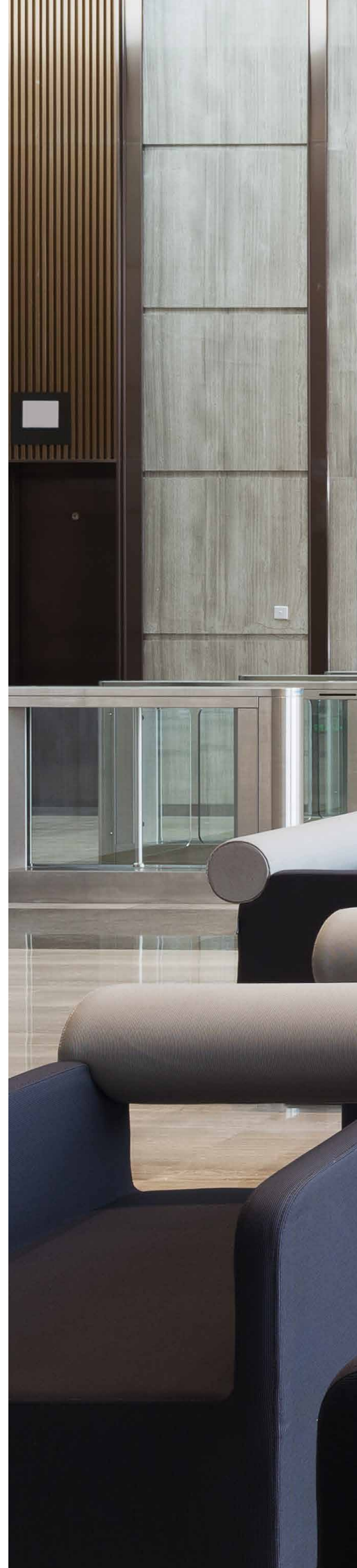

**One of the most
energy-efficient**



Advantage Range (Underceiling)

GMW

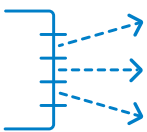

Motorised Swing Louvre

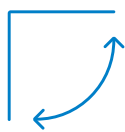

Hinged Return Air Filter

Advantage Range (GMW) Specifications



Model	GMW 50	GMW 70	GMW 80	GMW 140	GMW 160
Nominal Air Flow (l/s) * 'H Series'	175	240	375	625	815
Nominal Air Flow (l/s) * 'S Series'	150	170	295	520	N/A
Fan Type	Forward curved centrifugal double inlet double width				
Power Source **	1 Phase 230 Volt AC 50 Hz				
Full Load Amps (A) 'H Series'	0.45	0.9	0.7	1.4	2.0
Full Load Amps (A) 'S Series'	0.37	0.74	0.37	0.74	N/A
Fan Motor Type	Three speed, direct drive				
Heat Exchanger Type	Aluminium corrugated plate fins to expanded rifled copper tube				
Cooling/Heating Medium	Chilled Water or Hot Water				
Coil Connection - Cooling 2 Row	Ø 15 (½" BSP)	Ø 15 (½" BSP)	Ø 20 (¾" BSP)	Ø 20 (¾" BSP)	Ø 20 (¾" BSP)
Coil Connection - Cooling 3 Row	Ø 15 (½" BSP)	Ø 20 (¾" BSP)	Ø 20 (¾" BSP)	Ø 20 (¾" BSP)	Ø 25 (1" BSP)
Coil Connection - Heating 1 Row	Ø 15 (½" BSP)	Ø 15 (½" BSP)	Ø 15 (½" BSP)	Ø 15 (½" BSP)	Ø 15 (½" BSP)
Finish	Polyester Powder Coat + White PVC				
Test Pressure	2100 kPa				
Air Filter Type	Plastic Net - Washable				
Weight Incl. Water (kg)	28	40	51	79	79
Nett Dry Weight (kg)	27	38	48	74	74
Shipping Weight (kg)	30	41	51	78	78

* with standard screen filter fitted and a dry coil surface.

** voltage fluctuation limit 200-252V

Cooling and Heating Coil options:

3 Row Cooling Only

2 Row Cooling + 1 Row Heating

Fan Options

H-Series 4 Pole Motor

S-Series 6 Pole Motor

GMW50S-3

				Low Speed			Medium Speed			High Speed		
3 row chilled water coil				135 L/s			140 L/s			150 L/s		
Air on DB/WB	W. flow L/s	P.D. kPa	Cooling kW	Entering water temp			Entering water temp			Entering water temp		
				6	7	8	6	7	8	6	7	8
23/17	0.1	3.2	total	2.7	2.5	2.3	2.8	2.6	2.3	2.9	2.6	2.4
			sensible	1.9	1.8	1.7	1.9	1.8	1.7	2.0	1.9	1.8
	0.2	11.1	total	3.3	3.0	2.8	3.4	3.1	2.8	3.5	3.2	3.0
			sensible	2.1	2.0	1.9	2.2	2.1	1.9	2.3	2.2	2.0
	0.3	22.9	total	3.5	3.3	3.0	3.6	3.3	3.0	3.8	3.5	3.2
			sensible	2.2	2.1	2.0	2.3	2.2	2.0	2.4	2.3	2.1
27/19	0.1	3.2	total	3.3	3.1	2.9	3.4	3.2	2.9	3.5	3.2	3.0
			sensible	2.3	2.3	2.2	2.4	2.3	2.2	2.5	2.4	2.3
	0.2	11.1	total	4.1	3.8	3.5	4.2	3.9	3.6	4.3	4.0	3.7
			sensible	2.6	2.5	2.4	3.7	2.6	2.5	2.8	2.7	2.6
	0.3	22.9	total	4.4	4.1	3.8	4.5	4.2	3.9	4.6	4.3	4.0
			sensible	2.7	2.6	2.5	2.8	2.7	2.6	3.0	2.8	2.7

GMW50S-2/1

2 row chilled water coil				135 L/s			140 L/s			150 L/s		
Air on DB/WB	W. flow L/s	P.D. kPa	Cooling kW	Entering water temp			Entering water temp			Entering water temp		
				6	7	8	6	7	8	6	7	8
23/17	0.1	2.8	total	2.5	2.3	2.1	2.5	2.3	2.1	2.5	2.4	2.1
			sensible	1.7	1.6	1.6	1.7	1.7	1.6	1.8	1.7	1.7
	0.2	9.5	total	3.0	2.8	2.5	3.1	2.8	2.6	3.2	2.9	2.7
			sensible	1.9	1.8	1.7	2.0	1.9	1.8	2.1	2.0	1.9
	0.3	19.5	total	3.2	3.0	2.7	3.3	3.0	2.8	3.4	3.2	2.9
			sensible	2.0	1.9	1.8	2.1	2.0	1.9	2.2	2.1	1.9
27/19	0.1	2.8	total	3.0	2.8	2.6	3.0	2.8	2.6	3.1	2.9	2.7
			sensible	2.1	2.0	2.0	2.2	2.1	2.0	2.3	2.2	2.1
	0.2	9.5	total	3.7	3.4	3.2	3.8	3.5	3.2	3.9	3.6	3.4
			sensible	2.4	2.3	2.2	2.4	2.4	2.2	2.6	2.5	2.4
	0.3	19.5	total	4.0	3.7	3.4	4.1	3.8	3.5	4.2	3.9	3.6
			sensible	2.5	2.4	2.3	2.6	2.5	2.4	2.7	2.6	2.5

1 row hot water coil

Air on DB	W. flow L/s	P.D. kPa	Heating kW	Entering water temp			Entering water temp			Entering water temp		
				50	65	80	50	65	80	50	65	80
15	0.03	2.7	heat	1.3	1.8	2.4	1.3	1.9	2.4	1.3	1.9	2.5
	0.06	9.3	heat	1.5	2.1	2.7	1.5	2.1	2.8	1.5	2.2	2.9
	0.09	19.5	heat	1.6	2.3	2.9	1.6	2.3	3.0	1.6	2.3	3.1
21	0.03	2.7	heat	1.1	1.6	2.2	1.1	1.6	2.2	1.1	1.7	2.2
	0.06	9.3	heat	1.2	1.9	2.5	1.2	1.9	2.5	1.3	1.9	2.6
	0.09	19.5	heat	1.3	2.0	2.7	1.3	2.0	2.7	1.4	2.1	2.8

GMW50H-3

				Low Speed			Medium Speed			High Speed		
3 row chilled water coil				155 L/s			165 L/s			175 L/s		
Air on DB/WB	W. flow L/s	P.D. kPa	Cooling kW	Entering water temp			Entering water temp			Entering water temp		
				6	7	8	6	7	8	6	7	8
23/17	0.1	3.2	total	2.9	2.7	2.4	3.0	2.7	2.5	3.0	2.8	2.5
			sensible	2.0	1.9	1.8	2.1	2.0	1.9	2.2	2.1	2.0
	0.2	11.1	total	3.6	3.3	3.0	3.7	3.4	3.1	3.8	3.5	3.2
			sensible	2.3	2.2	2.1	2.4	2.3	2.2	2.5	2.4	2.3
	0.3	22.9	total	3.9	3.6	3.2	4.0	3.7	3.4	4.2	3.8	3.5
			sensible	2.4	2.3	2.2	2.6	2.4	2.3	2.7	2.5	2.4
27/19	0.1	3.2	total	3.5	3.3	3.0	3.6	3.3	3.1	3.7	3.4	3.1
			sensible	2.5	2.4	2.3	2.6	2.5	2.4	2.7	2.6	2.5
	0.2	11.1	total	4.4	4.1	3.8	4.5	4.2	3.9	4.7	4.4	4.0
			sensible	2.9	2.8	2.6	3.0	2.9	2.8	3.1	3.0	2.9
	0.3	22.9	total	4.7	4.4	4.1	4.9	4.6	4.3	5.1	4.8	4.4
			sensible	3.0	2.9	2.8	3.2	3.0	2.9	3.3	3.2	3.0

GMW50H-2/1

2 row chilled water coil				155 L/s			165 L/s			175 L/s		
Air on DB/WB	W. flow L/s	P.D. kPa	Cooling kW	Entering water temp			Entering water temp			Entering water temp		
				6	7	8	6	7	8	6	7	8
23/17	0.1	2.8	total	2.6	2.4	2.2	2.6	2.4	2.2	2.7	2.5	2.2
			sensible	1.9	1.8	1.7	1.9	1.8	1.7	2.0	1.9	1.8
	0.2	9.5	total	3.2	3.0	2.7	2.3	3.1	2.8	3.4	3.2	2.9
			sensible	2.1	2.0	1.9	2.2	2.1	2.0	2.3	2.2	2.1
	0.3	19.5	total	3.5	3.2	2.9	3.7	3.4	3.0	3.8	3.5	3.1
			sensible	2.2	2.1	2.0	2.3	2.2	2.1	2.4	2.3	2.2
27/19	0.1	2.8	total	3.1	2.9	2.7	3.2	3.0	2.8	3.3	3.1	2.8
			sensible	2.3	2.2	2.1	2.4	2.3	2.2	2.5	2.4	2.3
	0.2	9.5	total	4.0	3.7	3.4	4.1	3.8	3.5	4.2	3.9	3.6
			sensible	2.6	2.5	2.4	2.7	2.6	2.5	2.8	2.7	2.6
	0.3	19.5	total	4.3	4.0	3.7	4.5	4.2	3.9	4.6	4.3	4.0
			sensible	2.8	2.6	2.5	2.9	2.8	2.6	3.0	2.9	2.7

1 row hot water coil

Air on DB	W. flow L/s	P.D. kPa	Heating kW	Entering water temp			Entering water temp			Entering water temp		
				50	65	80	50	65	80	50	65	80
15	0.03	2.7	heat	1.4	2.0	2.5	1.4	2.0	2.6	1.4	2.0	2.7
	0.06	9.3	heat	1.6	2.2	2.9	1.6	2.3	3.0	1.6	2.4	3.1
	0.09	19.5	heat	1.7	2.4	3.1	1.7	2.5	3.2	1.8	2.5	3.3
21	0.03	2.7	heat	1.1	1.7	2.3	1.2	1.8	2.4	1.2	1.8	2.4
	0.06	9.3	heat	1.3	2.0	2.6	1.3	2.0	2.7	1.4	2.1	2.8
	0.09	19.5	heat	1.4	2.1	2.8	1.4	2.2	2.9	1.5	2.2	3.0

GMW70S-3

3 row chilled water coil				Low Speed			Medium Speed			High Speed		
				160 L/s			167 L/s			170 L/s		
Air on DB/WB	W. flow L/s	P.D. kPa	Cooling kW	Entering water temp			Entering water temp			Entering water temp		
				6	7	8	6	7	8	6	7	8
23/17	0.2	4.6	total	3.9	3.5	3.2	3.9	3.6	3.3	4.0	3.6	3.3
			sensible	2.5	2.4	2.2	2.6	2.4	2.3	2.6	2.5	2.3
	0.3	9.5	total	4.2	3.8	3.5	4.3	3.9	3.6	4.3	4.0	3.6
			sensible	2.6	2.5	2.3	2.7	2.6	2.4	2.7	2.6	2.4
	0.4	15.9	total	4.3	4.0	3.6	4.5	4.1	3.8	4.5	4.2	3.8
			sensible	2.7	2.6	2.4	2.8	2.6	2.5	2.8	2.7	2.5
27/19	0.2	4.6	total	4.7	4.4	4.1	4.8	4.5	4.2	4.9	4.5	5.2
			sensible	3.1	2.9	2.8	3.2	3.0	2.9	3.2	3.1	2.9
	0.3	9.5	total	5.1	4.8	4.4	5.3	4.9	4.5	5.3	5.0	4.6
			sensible	3.3	3.1	3.0	3.4	3.2	3.1	3.4	3.3	3.0
	0.4	15.9	total	5.3	5.0	4.6	5.5	5.1	4.8	5.5	5.2	4.8
			sensible	3.3	3.2	3.0	3.4	3.3	3.1	3.5	3.3	3.2

GMW70S-2/1

2 row chilled water coil				160 L/s			167 L/s			170 L/s		
Air on DB/WB	W. flow L/s	P.D. kPa	Cooling kW	Entering water temp			Entering water temp			Entering water temp		
				6	7	8	6	7	8	6	7	8
23/17	0.2	11.2	total	3.6	3.4	3.1	3.7	3.4	3.1	3.8	3.5	3.2
			sensible	2.3	2.2	2.1	2.4	2.3	2.2	2.4	2.3	2.2
	0.3	23.4	total	4.0	3.6	3.3	4.0	3.7	3.4	4.1	3.8	3.4
			sensible	2.5	2.3	2.2	2.5	2.4	2.3	2.6	2.4	2.3
	0.4	38.9	total	4.1	3.8	3.4	4.2	3.9	3.5	4.3	3.9	3.6
			sensible	2.5	2.4	2.3	2.6	2.5	2.3	2.6	2.5	2.3
27/19	0.2	11.2	total	4.5	4.2	3.8	4.6	4.3	4.0	4.6	4.3	4.0
			sensible	2.9	2.8	2.6	3.0	2.9	2.7	3.0	2.9	2.8
	0.3	23.4	total	4.8	4.5	4.2	5.0	4.6	4.3	4.9	4.7	4.4
			sensible	3.0	2.9	2.8	3.1	3.0	2.9	3.2	3.0	2.9
	0.4	38.9	total	5.0	4.7	4.4	5.1	4.8	4.4	5.2	4.9	4.5
			sensible	3.1	3.0	2.8	3.2	3.1	2.7	3.3	3.1	3.0

1 row hot water coil

Air on DB	W. flow L/s	P.D. kPa	Heating kW	Entering water temp			Entering water temp			Entering water temp		
				50	65	80	50	65	80	50	65	80
15	0.03	3.3	heat	1.6	2.5	2.9	1.6	2.3	2.9	1.6	2.3	3.0
	0.06	11.3	heat	1.8	2.6	3.4	1.9	2.7	3.5	1.9	2.7	3.5
	0.09	23.3	heat	2.0	2.8	3.7	2.0	2.9	3.7	2.0	2.9	3.8
21	0.03	3.3	heat	1.3	2.0	2.6	1.3	2.0	2.7	1.3	2.0	2.7
	0.06	11.3	heat	1.5	2.3	3.1	1.5	2.3	3.2	1.6	2.4	3.2
	0.09	23.3	heat	1.6	2.5	3.3	1.7	2.5	3.4	1.7	2.6	3.4

GMW70H-3

				Low Speed			Medium Speed			High Speed		
3 row chilled water coil				220 L/s			230 L/s			240 L/s		
Air on DB/WB	W. flow L/s	P.D. kPa	Cooling kW	Entering water temp			Entering water temp			Entering water temp		
				6	7	8	6	7	8	6	7	8
23/17	0.2	4.6	total	4.5	4.1	3.7	4.6	4.2	3.8	4.7	4.3	3.9
			sensible	3.0	2.9	2.7	3.1	3.0	2.8	3.2	3.1	2.9
	0.3	9.5	total	5.0	4.6	4.2	5.1	4.7	4.3	5.3	4.8	4.4
			sensible	3.3	3.1	2.9	3.4	3.2	3.0	3.5	3.3	3.1
	0.4	15.9	total	5.3	4.9	4.5	5.5	5.0	4.5	5.6	5.1	4.7
			sensible	3.4	3.2	3.0	3.5	3.3	3.1	3.6	3.4	3.2
27/19	0.2	4.6	total	5.5	5.1	4.7	5.6	5.2	4.8	5.7	5.3	4.9
			sensible	3.8	3.6	3.5	3.9	3.7	3.6	4.0	3.8	3.7
	0.3	9.5	total	6.1	5.7	5.3	6.3	5.9	5.4	6.4	6.0	5.6
			sensible	4.0	3.9	3.7	4.1	4.0	3.8	4.3	4.1	3.9
	0.4	15.9	total	6.5	6.1	5.6	6.7	6.2	5.8	6.9	6.4	5.9
			sensible	4.2	4.0	3.8	4.3	4.1	3.9	4.4	4.3	4.1

GMW70H-2/1

2 row chilled water coil				220 L/s			230 L/s			240 L/s		
Air on DB/WB	W. flow L/s	P.D. kPa	Cooling kW	Entering water temp			Entering water temp			Entering water temp		
				6	7	8	6	7	8	6	7	8
23/17	0.2	11.2	total	4.3	3.9	3.6	4.4	4.0	3.6	4.5	4.1	3.7
			sensible	2.9	2.7	2.6	2.9	2.8	2.7	3.0	2.9	2.7
	0.3	23.4	total	4.7	4.4	4.0	4.9	4.5	4.1	5.0	4.6	4.1
			sensible	3.1	2.9	2.7	3.1	3.0	2.8	3.2	3.1	2.9
	0.4	38.9	total	5.0	4.6	4.2	5.1	4.7	4.3	5.2	4.8	4.4
			sensible	3.2	3.0	2.8	3.2	3.1	2.9	3.3	3.2	3.0
27/19	0.2	11.2	total	5.2	4.9	4.5	5.3	5.0	4.6	5.4	5.1	4.7
			sensible	3.5	3.4	3.3	3.6	3.5	3.4	3.7	3.6	3.5
	0.3	23.4	total	5.8	5.4	5.0	6.0	5.5	5.1	6.1	5.6	5.2
			sensible	3.8	3.6	3.5	3.9	3.7	3.6	4.0	3.8	3.7
	0.4	38.9	total	6.1	5.7	5.3	6.3	5.8	5.4	6.4	6.0	5.5
			sensible	3.9	3.7	3.6	4.0	3.8	3.7	4.1	3.9	3.8

1 row hot water coil

Air on DB	W. flow L/s	P.D. kPa	Heating kW	Entering water temp			Entering water temp			Entering water temp		
				50	65	80	50	65	80	50	65	80
15	0.03	3.3	heat	1.8	2.6	3.3	1.8	2.6	3.4	1.8	2.6	3.4
	0.06	11.3	heat	2.1	3.0	3.9	2.1	3.0	3.9	2.2	3.1	4.0
	0.09	23.3	heat	2.3	3.2	4.2	2.3	3.3	4.3	2.3	3.3	4.3
21	0.03	3.3	heat	1.5	2.2	3.0	1.5	2.3	3.0	1.5	2.3	3.1
	0.06	11.3	heat	1.7	2.6	3.5	1.8	2.7	3.6	1.8	2.7	3.6
	0.09	23.3	heat	1.9	2.8	3.8	1.9	2.9	3.9	1.9	2.9	3.9

GMW80S-3

				Low Speed			Medium Speed			High Speed		
3 row chilled water coil				185 L/s			235 L/s			295 L/s		
Air on DB/WB	W. flow L/s	P.D. kPa	Cooling kW	Entering water temp			Entering water temp			Entering water temp		
				6	7	8	6	7	8	6	7	8
23/17	0.2	1.1	total	4.0	3.7	3.4	4.5	4.2	3.8	5.0	4.6	4.2
			sensible	2.8	2.7	2.5	3.3	3.2	3.0	3.8	3.7	3.5
	0.4	3.7	total	4.5	4.2	3.8	5.3	4.8	4.4	6.0	5.5	5.0
			sensible	3.1	2.9	2.7	3.7	3.5	3.3	4.3	4.1	3.9
	0.6	7.7	total	4.8	4.4	4.0	5.6	5.2	4.7	6.5	6.0	5.4
			sensible	3.2	3.0	2.8	3.8	3.6	3.4	4.5	4.3	4.1
27/19	0.2	1.1	total	5.0	4.6	4.3	5.6	5.2	4.8	6.1	5.7	5.3
			sensible	3.5	3.4	3.2	4.1	4.0	3.8	4.8	4.6	4.5
	0.4	3.7	total	5.6	5.2	4.8	6.4	6.0	5.6	7.3	6.8	6.3
			sensible	3.8	3.6	3.5	4.5	4.3	4.1	5.3	5.1	4.9
	0.6	7.7	total	5.9	5.5	5.1	6.9	6.5	6.0	8.0	7.4	6.9
			sensible	3.9	3.7	3.6	4.7	4.5	4.3	5.6	5.3	5.1

GMW80S-2/1

2 row chilled water coil				185 L/s			235 L/s			295 L/s		
Air on DB/WB	W. flow L/s	P.D. kPa	Cooling kW	Entering water temp			Entering water temp			Entering water temp		
				6	7	8	6	7	8	6	7	8
23/17	0.2	2.6	total	3.8	3.5	3.2	4.2	3.9	3.5	4.7	4.3	3.9
			sensible	2.7	2.5	2.4	3.1	3.0	2.8	3.6	3.4	3.3
	0.4	8.9	total	4.3	4.0	3.6	5.0	4.6	4.2	5.7	5.2	4.8
			sensible	2.9	2.7	2.6	3.4	3.3	3.1	4.0	3.8	3.6
	0.6	18.5	total	4.6	4.2	3.8	5.4	4.9	4.5	6.2	5.7	5.1
			sensible	3.0	3.8	2.7	3.6	3.4	3.2	4.2	4.0	3.8
27/19	0.2	2.6	total	4.7	4.4	4.0	5.2	4.9	4.5	5.7	5.3	4.9
			sensible	3.3	3.2	3.1	3.8	3.7	3.6	4.5	4.3	4.1
	0.4	8.9	total	5.3	5.0	4.6	6.2	5.7	5.3	6.9	6.5	6.0
			sensible	3.6	3.4	3.3	4.3	4.1	3.9	4.9	4.7	4.6
	0.6	18.5	total	5.7	5.3	4.9	6.6	6.2	5.7	7.6	7.1	6.6
			sensible	3.7	3.6	3.4	4.4	4.3	4.1	5.2	5.0	4.8

1 row hot water coil

Air on DB	W. flow L/s	P.D. kPa	Heating kW	Entering water temp			Entering water temp			Entering water temp		
				50	65	80	50	65	80	50	65	80
15	0.1	5.5	heat	2.3	3.4	4.4	2.7	3.9	5.0	3.1	4.4	5.7
	0.15	11	heat	2.4	3.5	4.5	2.8	4.0	5.2	3.3	4.6	6.0
	0.2	18.6	heat	2.5	3.6	4.6	2.9	4.2	5.4	3.4	4.8	6.3
21	0.1	5.5	heat	1.9	2.9	3.9	2.2	3.4	4.5	2.5	3.8	5.1
	0.15	11	heat	2.0	3.0	4.1	2.3	3.5	4.7	2.7	4.1	5.4
	0.2	18.6	heat	2.1	3.1	4.2	2.4	3.6	4.9	2.8	4.2	5.7

GMW80H-3

				Low Speed			Medium Speed			High Speed		
3 row chilled water coil				265 L/s			295 L/s			375 L/s		
Air on DB/WB	W. flow L/s	P.D. kPa	Cooling kW	Entering water temp			Entering water temp			Entering water temp		
				6	7	8	6	7	8	6	7	8
23/17	0.2	1.1	total	4.8	4.4	4.0	5.0	4.6	4.2	5.4	5.0	4.5
			sensible	3.6	3.4	3.3	3.8	3.7	3.5	4.5	4.3	4.1
	0.4	3.7	total	5.6	5.2	4.7	6.0	5.5	5.0	6.7	6.2	5.6
			sensible	4.0	3.8	3.6	4.3	4.1	3.9	5.0	4.8	4.5
	0.6	7.7	total	6.0	5.5	5.0	6.5	6.0	5.4	7.4	6.8	6.2
			sensible	4.1	3.9	3.7	4.5	4.3	4.1	5.3	5.0	4.8
27/19	0.2	1.1	total	5.8	5.5	5.0	6.1	5.7	5.3	6.6	6.1	5.7
			sensible	4.5	4.3	4.2	4.8	4.6	4.5	5.6	5.4	5.2
	0.4	3.7	total	6.9	6.4	6.0	7.3	6.8	6.3	8.2	7.6	7.1
			sensible	4.9	4.7	4.5	5.3	5.1	4.9	6.2	6.0	5.7
	0.6	7.7	total	7.5	7.0	6.4	8.0	7.4	6.9	9.1	8.5	7.8
			sensible	5.2	5.0	4.7	5.6	5.3	5.1	6.6	6.3	6.0

GMW80H-2/1

2 row chilled water coil				265 L/s			295 L/s			375 L/s		
Air on DB/WB	W. flow L/s	P.D. kPa	Cooling kW	Entering water temp			Entering water temp			Entering water temp		
				6	7	8	6	7	8	6	7	8
23/17	0.2	2.6	total	4.5	4.1	3.7	4.7	4.3	3.9	5.1	4.7	4.2
			sensible	3.3	3.2	3.0	3.6	3.4	3.3	4.1	4.0	3.8
	0.4	8.9	total	5.3	4.9	4.5	5.7	5.2	4.8	6.4	5.9	5.3
			sensible	3.7	3.5	3.3	4.0	3.8	3.6	4.7	4.5	4.2
	0.6	18.5	total	5.8	5.3	4.8	6.2	5.7	5.1	7.1	6.5	5.9
			sensible	3.9	3.7	3.5	4.2	4.0	3.8	5.0	4.7	4.5
27/19	0.2	2.6	total	5.5	5.1	4.7	5.7	5.3	4.9	6.2	5.8	5.4
			sensible	4.2	4.0	3.9	4.5	4.3	4.1	5.2	5.0	4.8
	0.4	8.9	total	6.6	6.1	5.7	6.9	6.5	6.0	7.8	7.3	6.7
			sensible	4.6	4.4	4.3	4.9	4.7	4.6	5.8	5.6	5.4
	0.6	18.5	total	7.2	6.7	6.2	7.6	7.1	6.6	8.8	8.1	7.5
			sensible	4.9	4.7	4.4	5.2	5.0	4.8	6.2	5.9	5.7

1 row hot water coil

Air on DB	W. flow L/s	P.D. kPa	Heating kW	Entering water temp			Entering water temp			Entering water temp		
				50	65	80	50	65	80	50	65	80
15	0.1	5.5	heat	2.9	4.1	5.4	3.1	4.4	5.7	3.5	5.0	6.5
	0.15	11	heat	3.1	4.4	5.7	3.3	4.6	6.0	3.7	5.3	6.9
	0.2	18.6	heat	3.2	4.5	5.9	3.4	4.8	6.3	3.9	5.5	7.2
21	0.1	5.5	heat	2.4	3.6	4.8	2.5	3.8	5.1	2.9	4.3	5.8
	0.15	11	heat	2.5	3.8	5.1	2.7	4.1	5.4	3.1	4.7	6.2
	0.2	18.6	heat	2.6	3.9	5.3	2.8	4.2	5.7	3.2	4.9	6.5

GMW140S-3

				Low Speed			Medium Speed			High Speed		
3 row chilled water coil				380 L/s			440 L/s			520 L/s		
Air on DB/WB	W. flow L/s	P.D. kPa	Cooling kW	Entering water temp			Entering water temp			Entering water temp		
				6	7	8	6	7	8	6	7	8
23/17	0.4	5.0	total	8.0	7.4	6.7	8.6	7.9	7.2	9.3	8.6	7.8
			sensible	5.7	5.4	5.1	6.3	6.0	5.7	7.0	6.7	6.4
	0.75	15.6	total	9.1	8.4	7.6	10.0	9.2	8.3	11.1	10.2	9.2
			sensible	6.2	5.9	5.5	6.9	6.5	6.1	7.7	7.4	6.9
	1.1	31.0	total	9.6	8.8	8.0	10.7	9.8	8.9	11.9	11.0	10.0
			sensible	6.4	6.0	5.7	7.2	6.7	6.4	8.1	7.7	7.3
27/19	0.4	5.0	total	9.8	9.1	8.5	10.6	9.8	9.1	11.4	10.7	9.8
			sensible	7.0	6.7	6.5	7.8	7.5	7.2	8.7	8.4	8.0
	0.75	15.6	total	11.2	10.4	9.7	12.3	11.4	10.6	13.5	12.6	11.7
			sensible	7.6	7.3	6.9	8.5	8.1	7.8	9.5	9.1	8.8
	1.1	31.0	total	11.8	11.0	10.2	13.1	12.2	11.3	14.6	13.7	12.6
			sensible	7.9	7.6	7.2	8.8	8.5	8.1	10.0	9.6	9.2

GMW140S-2/1

2 row chilled water coil				380 L/s			440 L/s			520 L/s		
Air on DB/WB	W. flow L/s	P.D. kPa	Cooling kW	Entering water temp			Entering water temp			Entering water temp		
				6	7	8	6	7	8	6	7	8
23/17	0.3	7.3	total	7.0	6.4	5.9	7.5	6.9	6.2	8.0	7.3	6.7
			sensible	5.1	4.8	4.6	5.6	5.3	5.1	6.2	5.9	5.6
	0.5	18.3	total	8.0	7.4	6.7	8.7	8.0	7.2	9.5	8.7	7.9
			sensible	5.5	5.2	4.9	6.1	5.8	5.5	6.8	6.5	6.1
	0.7	33.5	total	8.6	7.9	7.2	9.4	8.6	7.8	10.4	9.5	8.7
			sensible	5.8	5.5	5.1	6.4	6.1	5.7	7.2	6.8	6.4
27/19	0.3	7.3	total	8.6	8.1	7.5	9.2	8.5	7.9	9.8	9.1	8.5
			sensible	6.3	6.1	5.8	6.9	6.7	6.4	7.7	7.4	7.2
	0.5	18.3	total	9.9	9.2	8.5	10.7	10.0	9.2	11.6	10.8	10.0
			sensible	6.8	6.5	6.2	7.5	7.2	6.9	8.4	8.1	7.8
	0.7	33.5	total	10.6	9.9	9.1	11.5	10.7	10.0	12.8	11.9	11.0
			sensible	7.1	6.8	6.5	7.9	7.5	7.2	8.9	8.5	8.1

1 row hot water coil

Air on DB	W. flow L/s	P.D. kPa	Heating kW	Entering water temp			Entering water temp			Entering water temp		
				50	65	80	50	65	80	50	65	80
15	0.05	2.3	heat	3.6	5.1	6.6	3.8	5.4	7.1	4.1	5.8	7.6
	0.1	7.6	heat	4.1	5.9	7.7	4.4	6.4	8.3	4.8	6.9	9.0
	0.15	15.3	heat	4.4	6.3	8.1	4.8	6.8	8.9	5.2	7.5	9.7
21	0.05	2.3	heat	2.9	4.4	5.9	3.1	4.7	6.4	3.3	5.1	6.9
	0.1	7.6	heat	3.4	5.1	6.9	3.7	5.6	7.5	4.0	6.1	8.1
	0.15	15.3	heat	3.6	5.5	7.3	3.9	6.0	8.0	4.3	6.5	8.8

GMW140H-3

				Low Speed			Medium Speed			High Speed		
3 row chilled water coil				450 L/s			520 L/s			625 L/s		
Air on DB/WB	W. flow L/s	P.D. kPa	Cooling kW	Entering water temp			Entering water temp			Entering water temp		
				6	7	8	6	7	8	6	7	8
23/17	0.4	5.0	total	8.7	8.0	7.3	9.3	8.5	7.7	10.1	9.3	8.5
			sensible	6.3	6.1	5.7	7.0	6.7	6.3	7.9	7.6	7.2
	0.75	15.6	total	10.1	9.3	8.4	11.0	10.1	9.2	12.2	11.2	10.2
			sensible	7.0	6.6	6.2	7.7	7.3	6.9	8.8	8.4	7.9
	1.1	31.0	total	10.8	9.9	9.0	11.9	10.9	9.9	13.4	12.3	11.2
			sensible	7.3	6.9	6.5	8.1	7.7	7.2	9.3	8.8	8.3
27/19	0.4	5.0	total	10.7	9.9	9.2	11.4	10.6	9.8	12.3	11.4	10.6
			sensible	7.9	7.6	7.3	8.7	8.4	8.0	9.8	9.4	9.1
	0.75	15.6	total	12.4	11.6	10.7	13.5	12.6	11.6	15.0	13.9	12.9
			sensible	8.6	8.2	7.9	9.5	9.1	8.7	10.9	10.4	10.0
	1.1	31.0	total	13.3	12.4	11.5	14.6	13.7	12.6	16.4	15.3	14.1
			sensible	9.0	8.6	8.2	10.0	9.6	9.2	11.5	11.0	10.5

GMW140H-2/1

2 row chilled water coil				450 L/s			520 L/s			625 L/s		
Air on DB/WB	W. flow L/s	P.D. kPa	Cooling kW	Entering water temp			Entering water temp			Entering water temp		
				6	7	8	6	7	8	6	7	8
23/17	0.3	7.3	total	7.5	6.9	6.3	8.0	7.3	6.7	8.6	7.8	7.1
			sensible	5.6	5.4	5.1	6.2	5.9	5.6	6.9	6.6	6.3
	0.5	18.3	total	8.8	8.0	7.3	9.5	8.7	7.9	10.3	9.5	8.6
			sensible	6.2	5.9	5.6	6.8	6.5	6.1	7.6	7.3	6.9
	0.7	33.5	total	9.5	8.7	7.9	10.4	9.5	8.7	11.4	10.5	9.5
			sensible	6.5	6.1	5.8	7.2	6.8	6.4	8.1	7.7	7.3
27/19	0.3	7.3	total	9.2	8.6	8.0	9.8	9.1	8.5	10.4	9.8	9.0
			sensible	7.0	6.7	6.5	7.7	7.4	7.2	8.6	8.3	8.0
	0.5	18.3	total	10.8	10.1	9.3	11.6	10.8	10.0	12.7	11.8	10.9
			sensible	7.6	7.3	7.0	8.4	8.1	7.8	9.5	9.1	8.8
	0.7	33.5	total	11.7	10.9	10.2	12.8	11.9	11.0	14.1	13.1	12.1
			sensible	8.0	7.7	7.3	8.9	8.5	8.1	10.0	9.6	9.3

1 row hot water coil

Air on DB	W. flow L/s	P.D. kPa	Heating kW	Entering water temp			Entering water temp			Entering water temp		
				50	65	80	50	65	80	50	65	80
15	0.05	2.3	heat	3.8	5.5	7.1	4.1	5.8	7.5	4.3	6.1	8.1
	0.1	7.6	heat	4.5	6.4	8.4	4.8	6.9	9.0	5.3	7.6	9.9
	0.15	15.3	heat	4.8	6.9	9.0	5.2	7.5	9.7	5.8	8.3	10.8
21	0.05	2.3	heat	3.2	4.8	6.4	3.3	5.1	6.8	3.6	5.4	7.3
	0.1	7.6	heat	3.7	5.6	7.6	4.0	6.1	8.1	4.4	6.7	8.9
	0.15	15.3	heat	4.0	6.1	8.1	4.3	6.5	8.8	4.8	7.2	9.7

GMW160H-3

				Low Speed			Medium Speed			High Speed		
3 row chilled water coil				665 L/s			725 L/s			815 L/s		
Air on DB/WB	W. flow L/s	P.D. kPa	Cooling kW	Entering water temp			Entering water temp			Entering water temp		
				6	7	8	6	7	8	6	7	8
23/17	0.4	5.0	total	10.3	9.5	8.6	10.7	9.8	8.9	11.2	10.3	9.4
			sensible	8.2	7.8	7.5	8.6	8.3	7.9	9.3	8.9	8.6
	0.75	15.6	total	12.6	11.6	10.5	13.2	12.1	11.0	14.0	12.8	11.7
			sensible	9.1	8.7	8.2	9.7	9.2	8.7	10.4	10.0	9.5
	1.1	31.0	total	13.9	12.7	11.5	14.6	13.4	12.2	15.7	14.4	13.1
			sensible	9.7	9.2	8.6	10.3	9.7	9.2	11.2	10.7	10.1
27/19	0.4	5.0	total	12.6	11.7	10.9	13.0	12.1	11.2	13.6	12.6	11.7
			sensible	10.2	9.8	9.5	10.7	10.4	10.1	11.6	11.2	10.9
	0.75	15.6	total	15.5	14.4	13.3	16.2	15.1	13.9	17.2	15.9	14.7
			sensible	11.3	10.9	10.5	12.0	11.5	11.1	13.0	12.5	12.0
	1.1	31.0	total	17.0	15.9	14.7	18.0	16.7	15.5	19.2	17.9	16.5
			sensible	12.0	11.5	11.0	12.7	12.2	11.7	13.8	13.3	12.7

GMW160H-2/1

2 row chilled water coil				665 L/s			725 L/s			815 L/s		
Air on DB/WB	W. flow L/s	P.D. kPa	Cooling kW	Entering water temp			Entering water temp			Entering water temp		
				6	7	8	6	7	8	6	7	8
23/17	0.3	7.3	total	8.7	8.0	7.3	9.0	8.3	7.5	9.3	8.6	7.8
			sensible	7.2	6.9	6.6	7.5	7.3	7.0	8.1	7.8	7.5
	0.5	18.3	total	10.7	9.8	8.9	11.0	10.2	9.2	11.7	10.7	9.7
			sensible	7.9	7.6	7.2	8.4	8.0	7.6	9.0	8.6	8.2
	0.7	33.5	total	11.9	10.9	9.8	12.4	11.3	10.3	13.1	12.0	10.9
			sensible	8.4	8.0	7.6	8.9	8.5	8.1	9.6	9.1	8.7
27/19	0.3	7.3	total	10.7	9.9	9.2	11.0	10.2	9.5	11.4	10.6	9.8
			sensible	9.0	8.7	8.4	9.4	9.1	8.9	10.1	9.9	9.6
	0.5	18.3	total	13.0	12.1	11.2	13.5	12.6	11.7	14.2	13.2	12.2
			sensible	9.8	9.5	9.1	10.4	10.0	9.7	11.2	10.8	10.4
	0.7	33.5	total	14.5	13.5	12.5	15.2	14.1	13.0	16.1	15.0	13.8
			sensible	10.5	10.0	9.6	11.0	10.6	10.2	11.9	11.5	11.0

1 row hot water coil				Entering water temp			Entering water temp			Entering water temp		
Air on DB	W. flow L/s	P.D. kPa	Heating kW	50	65	80	50	65	80	50	65	80
				15	0.05	2.3	heat	4.4	6.3	8.2	4.5	6.5
0.1	7.6	heat	5.5		7.8	10.2	5.7	8.2	10.6	6.0	8.6	11.2
0.15	15.3	heat	6.0		8.5	11.1	6.3	9.0	11.7	6.7	9.5	12.4
21	0.05	2.3	heat	3.6	5.5	7.4	3.7	5.7	7.6	3.9	5.9	7.9
	0.1	7.6	heat	4.5	6.9	9.2	4.7	7.1	9.6	4.9	7.5	10.1
	0.15	15.3	heat	4.9	7.5	10.0	5.2	7.9	10.6	5.5	8.4	11.2

Performance Data

Dimensions

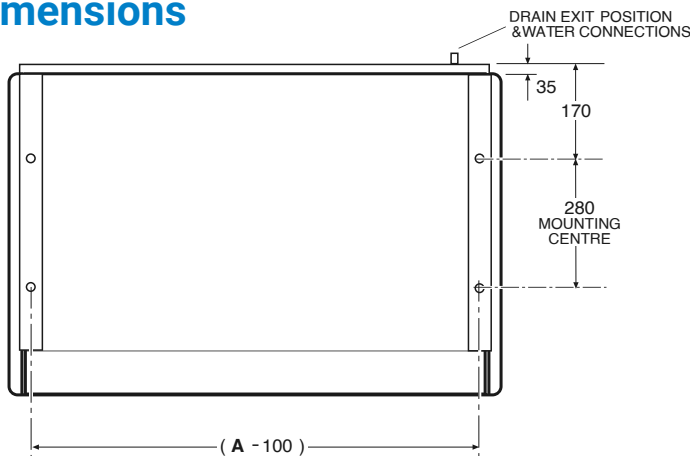

Model	A	B	C
GMW50	1000	190	35
GMW70	1260	190	35
GMW80	1260	255	100
GMW140	1860	255	100
GMW160	1860	255	100

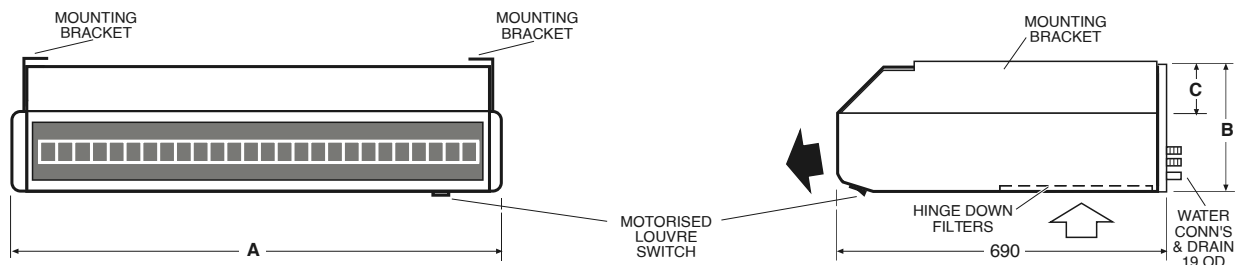

Sound Levels

As measured in an anechoic chamber 1m below and 1m to the front of the unit. No allowance for sound reflection in a room. Add 13dB to convert to sound power levels (SWL)

Supply Air Outlet									
Model	Air Flow L/s	Fan Speed	Sound Pressure Levels (SPL) (dB)						
			dB(A)	Octave Band Centre Frequency (Hz)					
				125	250	500	1K	2K	4K
GMW50S	135	LOW	33	37	32	33	27	19	13
	140	MED	34	38	33	34	28	20	14
	150	HIGH	34	37	33	34	28	22	16
GMW50H	155	LOW	41	39	39	41	37	32	24
	165	MED	43	40	40	42	39	34	26
	175	HIGH	44	41	42	43	40	35	28
GMW70S	160	LOW	33	37	32	34	27	20	13
	167	MED	34	39	34	35	28	20	14
	170	HIGH	34	40	34	35	30	22	14
GMW70H	220	LOW	44	40	42	44	40	33	27
	230	MED	45	41	43	43	41	36	29
	240	HIGH	46	42	44	46	42	37	30
GMW80S	185	LOW	33	37	34	32	25	21	13
	235	MED	37	38	38	36	31	25	17
	295	HIGH	42	43	43	41	38	32	23
GMW80H	265	LOW	41	41	45	41	35	28	20
	295	MED	43	42	46	44	37	31	24
	375	HIGH	48	48	48	47	44	39	32
GMW140S	380	LOW	37	43	37	36	31	25	17
	440	MED	40	45	40	39	35	29	20
	520	HIGH	43	44	43	41	38	33	25
GMW140H	450	LOW	43	44	43	42	39	32	24
	520	MED	46	47	47	45	43	36	29
	625	HIGH	51	51	51	49	48	42	35
GMW160H	665	LOW	51	51	51	50	47	41	35
	725	MED	53	53	53	51	50	44	37
	815	HIGH	53	55	55	53	52	46	40

Elementary Range (Low Profile)

MKT

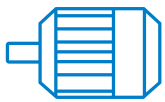
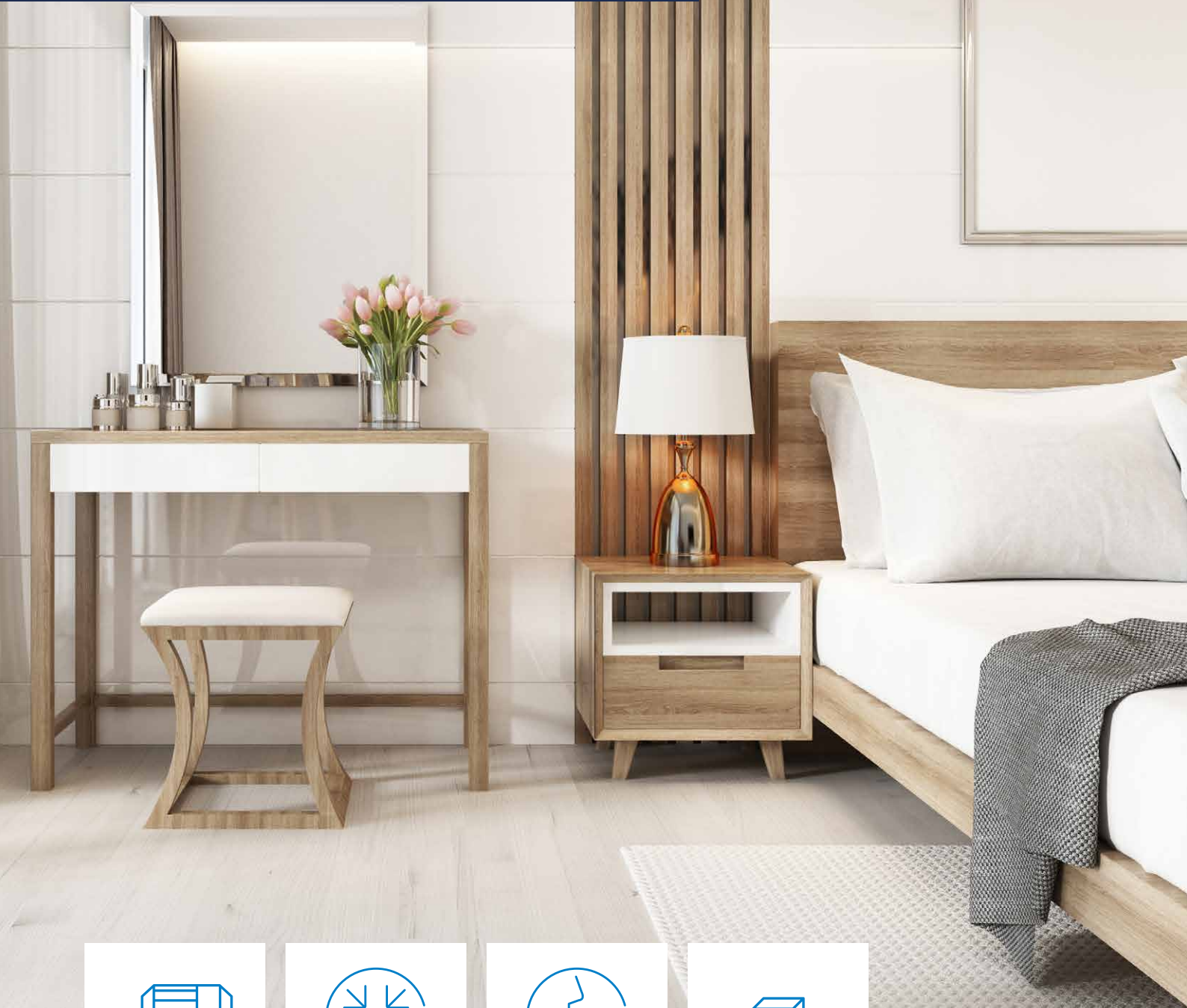

BLDC Motor



Lightweight & Compact



Low Noise Operation



Opposite Hand

Elementary Range (MKT) Specifications



Model		MKT 200	MKT 300	MKT 400	MKT 500	MKT 600	MKT 800	MKT 1000	MKT 1200
Nominal Air Flow (l/s) @ 50Pa setting *	High	89	125	147	191	250	344	447	514
	Med	58	94	108	130	186	233	322	389
	Low	39	78	72	102	122	186	219	270
External Static (Pa)	----- The factory default setting is 12Pa, can be set to 30Pa or 50Pa in the field -----								
Fan Type	----- Forward curved centrifugal double inlet double width -----								
No. of Fan Scrolls	1	2	2	2	2	4	4	4	
Motor Type	----- BLDC -----								
Power Supply **	----- 1 phase 230 volt, 50 hertz -----								
No. of Motors	1	1	1	1	1	2	2	2	
Motor Rating (W)	34	51	68	85	102	136	170	204	
Heat Exchanger Type	----- Copper tube 9.5mm, hydrophilic aluminium fins -----								
Cooling/Heating Medium	----- Chilled Water and / or Hot Water -----								
Finish	----- Galvanised steel -----								
Max Pressure (kPa)	----- 1600 -----								
Connection Sizes Cooling Coil (mm)	----- 20mm (3/4" BSP) -----								
Connection Sizes Heating Coil (mm)	----- 20mm (3/4" BSP) -----								
Air Filter	----- Washable -----								
Weight (excl water) (kg)	17.2	19.5	21.5	21.5	24.2	33.5	25.2	39.7	
Shipping Weight (kg)	20.2	22.5	24.5	24.5	27.7	37.7	39.7	44.9	

* with no filter fitted and a dry coil surface.

** voltage fluctuation limit 200-252V

Cooling and Heating Coil options:

4 Row Cooling Only

2 Row Cooling + 1 Row Heating

MKT4-V200

				Low Speed			Medium Speed			High Speed		
4 row chilled water coil				60 L/s			80 L/s			100 L/s		
Air on DB/WB	W. flow L/s	P.D. kPa	Cooling kW	Entering water temp			Entering water temp			Entering water temp		
				6	7	8	6	7	8	6	7	8
23/17	0.2	6.7	total	1.61	1.48	1.35	1.97	1.81	1.64	2.28	2.09	1.91
			sensible	1.06	1.00	0.94	1.31	1.24	1.17	1.55	1.46	1.37
	0.3	13.5	total	1.66	1.54	1.40	2.07	1.91	1.74	2.43	2.24	2.04
			sensible	1.09	1.03	0.96	1.36	1.28	1.22	1.62	1.53	1.43
	0.4	22.2	total	1.69	1.56	1.42	2.12	1.96	1.79	2.51	2.31	2.11
			sensible	1.10	1.04	0.97	1.39	1.31	1.24	1.65	1.56	1.46
27/19	0.2	6.7	total	1.95	1.82	1.69	2.39	2.23	2.07	2.77	2.59	2.40
			sensible	1.30	1.24	1.19	1.61	1.54	1.46	1.90	1.81	1.73
	0.3	13.5	total	2.02	1.89	1.76	2.51	2.36	2.19	2.96	2.77	2.57
			sensible	1.34	1.28	1.22	1.67	1.60	1.52	1.98	1.89	1.80
	0.4	22.2	total	2.05	1.92	1.78	2.58	2.42	2.25	3.05	2.86	2.65
			sensible	1.35	1.28	1.22	1.71	1.63	1.55	2.03	1.93	1.84

MKT3-V200

2 row chilled water coil				60 L/s			80 L/s			100 L/s		
Air on DB/WB	W. flow L/s	P.D. kPa	Cooling kW	Entering water temp			Entering water temp			Entering water temp		
				6	7	8	6	7	8	6	7	8
23/17	0.1	5.6	total	1.43	1.31	1.19	1.62	1.49	1.35	1.80	1.65	1.50
			sensible	0.98	0.93	0.87	1.15	1.08	1.03	1.30	1.24	1.17
	0.2	18.5	total	1.61	1.48	1.35	1.90	1.75	1.59	2.17	2.00	1.82
			sensible	1.07	1.01	0.95	1.27	1.20	1.13	1.47	1.39	1.31
	0.3	37.8	total	1.67	1.54	1.40	2.00	1.84	1.68	2.31	2.13	1.94
			sensible	1.09	1.03	0.97	1.32	1.24	1.17	1.54	1.45	1.37
27/19	0.1	5.6	total	1.74	1.62	1.50	1.97	1.84	1.70	2.19	2.04	1.89
			sensible	1.21	1.15	1.10	1.41	1.35	1.29	1.61	1.54	1.48
	0.2	18.5	total	1.96	1.83	1.70	2.31	2.16	2.00	2.66	2.47	2.29
			sensible	1.31	1.25	1.19	1.56	1.49	1.42	1.81	1.73	1.65
	0.3	37.8	total	2.03	1.90	1.77	2.43	2.27	2.11	2.82	2.63	2.45
			sensible	1.35	1.28	1.22	1.62	1.54	1.47	1.89	1.80	1.72

1 row hot water coil

Air on DB	W. flow L/s	P.D. kPa	Heating kW	Entering water temp			Entering water temp			Entering water temp		
				50	65	80	50	65	80	50	65	80
15	0.03	1.8	heat	1.46	2.12	2.78	1.53	2.21	2.90	1.65	2.40	3.15
	0.06	6	heat	1.67	2.42	3.16	1.78	2.57	3.36	1.97	2.84	3.72
	0.09	12.9	heat	1.75	2.52	3.30	1.88	2.70	3.54	2.09	3.01	3.94
21	0.03	1.8	heat	1.22	1.88	2.54	1.26	1.94	2.62	1.37	2.10	2.85
	0.06	6	heat	1.39	2.14	2.89	1.46	2.24	3.03	1.62	2.48	3.35
	0.09	12.9	heat	1.46	2.23	3.01	1.54	2.36	3.18	1.72	2.63	3.55

MKT3-V200 (12Pa)

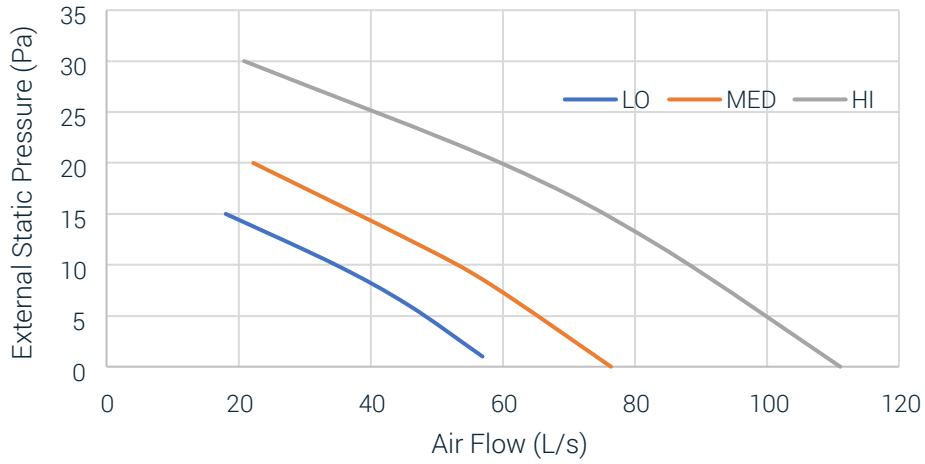

MKT3-V200 (30Pa)

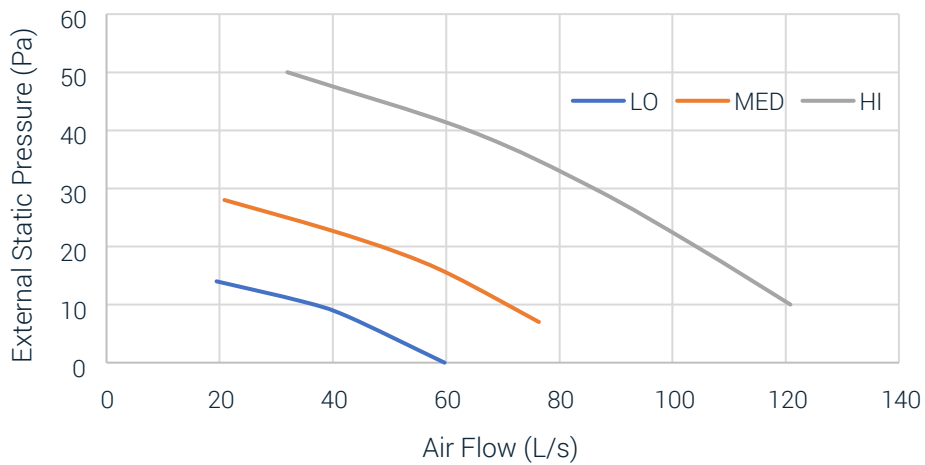

MKT3-V200 (50Pa)

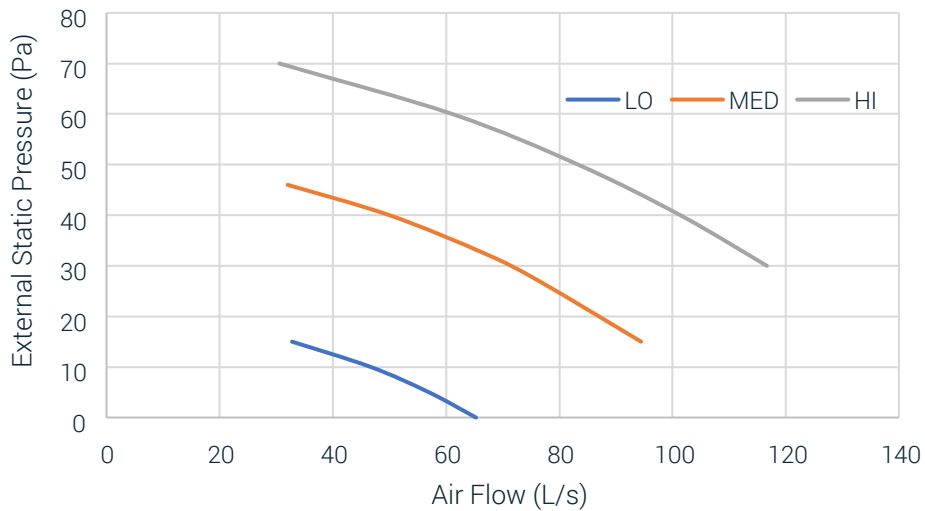

MKT4-V300

				Low Speed			Medium Speed			High Speed		
4 row chilled water coil				90 L/s			120 L/s			150 L/s		
Air on DB/WB	W. flow L/s	P.D. kPa	Cooling kW	Entering water temp			Entering water temp			Entering water temp		
				6	7	8	6	7	8	6	7	8
23/17	0.2	7.5	total	2.22	2.04	1.86	2.68	2.46	2.25	3.05	2.80	2.55
			sensible	1.49	1.41	1.32	1.83	1.73	1.63	2.12	2.00	1.89
	0.3	15	total	2.34	2.15	1.96	2.88	2.65	2.42	3.33	3.06	2.79
			sensible	1.55	1.46	1.37	1.93	1.82	1.71	2.24	2.12	1.99
	0.4	25	total	2.40	2.21	2.02	2.99	2.75	2.51	3.48	3.20	2.92
			sensible	1.58	1.49	1.39	1.97	1.86	1.75	2.31	2.18	2.05
27/19	0.2	7.5	total	2.70	2.52	2.34	3.26	3.04	2.82	3.71	3.46	3.20
			sensible	1.82	1.74	1.66	2.24	2.15	2.05	2.60	2.49	2.38
	0.3	15	total	2.85	2.66	2.47	3.51	3.28	3.04	4.06	3.79	3.51
			sensible	1.89	1.80	1.72	2.36	2.25	2.15	2.76	2.64	2.51
	0.4	25	total	2.92	2.73	2.54	3.63	3.40	3.16	4.24	3.96	3.68
			sensible	1.93	1.84	1.75	2.42	2.31	2.20	2.84	2.71	2.58

MKT3-V300

2 row chilled water coil				90 L/s			120 L/s			150 L/s		
Air on DB/WB	W. flow L/s	P.D. kPa	Cooling kW	Entering water temp			Entering water temp			Entering water temp		
				6	7	8	6	7	8	6	7	8
23/17	0.1	6.8	total	1.82	1.66	1.51	2.06	1.89	1.72	2.25	2.06	1.88
			sensible	1.29	1.22	1.16	1.52	1.44	1.37	1.71	1.63	1.55
	0.2	22.5	total	2.13	1.95	1.79	2.54	2.33	2.12	2.86	2.63	2.39
			sensible	1.43	1.35	1.28	1.73	1.64	1.54	1.98	1.87	1.77
	0.3	44.9	total	2.24	2.06	1.89	2.72	2.50	2.28	3.11	2.86	2.60
			sensible	1.48	1.39	1.32	1.82	1.71	1.61	2.09	1.98	1.86
27/19	0.1	6.8	total	2.20	2.03	1.91	2.51	2.34	2.17	2.74	2.55	2.37
			sensible	1.58	1.51	1.45	1.87	1.80	1.73	2.11	2.04	1.96
	0.2	22.5	total	2.60	2.43	2.25	3.10	2.89	2.68	3.49	3.25	3.01
			sensible	1.76	1.68	1.61	2.13	2.04	1.94	2.44	2.33	2.23
	0.3	44.9	total	2.73	2.55	2.38	3.32	3.10	2.88	3.79	3.54	3.28
			sensible	1.82	1.74	1.66	2.23	2.13	2.03	2.58	2.46	2.34

1 row hot water coil

Air on DB	W. flow L/s	P.D. kPa	Heating kW	Entering water temp			Entering water temp			Entering water temp		
				50	65	80	50	65	80	50	65	80
15	0.03	2.3	heat	1.74	2.52	3.31	1.93	2.79	3.66	2.06	2.98	3.91
	0.06	7.4	heat	2.05	2.96	3.88	2.35	3.38	4.43	2.56	3.70	4.84
	0.09	13.5	heat	2.18	3.13	4.11	2.52	3.62	4.74	2.78	4.00	5.23
21	0.03	2.3	heat	1.44	2.21	2.99	1.59	2.45	3.31	1.70	2.62	3.54
	0.06	7.4	heat	1.70	2.60	3.50	1.93	2.96	4.00	2.12	3.24	4.38
	0.09	13.5	heat	1.80	2.74	3.71	2.07	3.17	4.27	2.29	3.50	4.72

MKT3-V300 (12Pa)

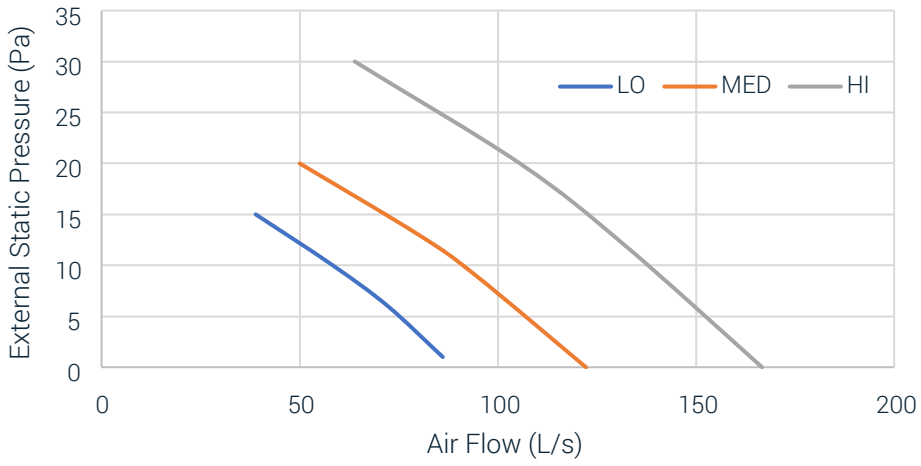

MKT3-V300 (30Pa)

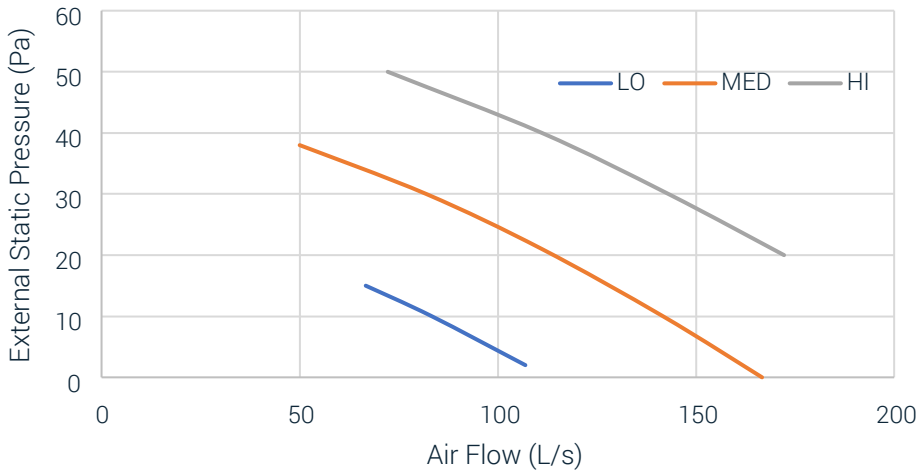

MKT3-V300 (50Pa)

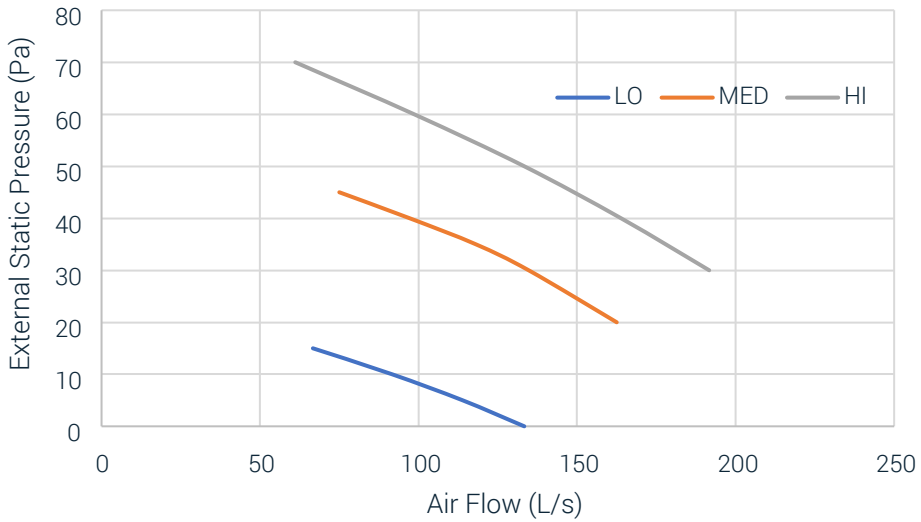

MKT4-V400

				Low Speed			Medium Speed			High Speed		
4 row chilled water coil				100 L/s			150 L/s			200 L/s		
Air on DB/WB	W. flow L/s	P.D. kPa	Cooling kW	Entering water temp			Entering water temp			Entering water temp		
				6	7	8	6	7	8	6	7	8
23/17	0.2	8.6	total	2.44	2.25	2.05	3.13	2.88	2.62	3.65	3.35	3.04
			sensible	1.64	1.55	1.46	2.16	2.04	1.93	2.59	2.45	2.32
	0.3	17.3	total	2.58	2.38	2.17	3.41	3.13	2.85	4.08	3.74	3.40
			sensible	1.71	1.61	1.52	2.29	2.14	2.03	2.78	2.62	2.48
	0.4	28.3	total	2.65	2.44	2.23	3.55	3.26	2.98	4.29	3.94	3.59
			sensible	1.74	1.64	1.54	2.36	2.22	2.09	2.88	2.72	2.56
27/19	0.2	8.6	total	2.97	2.78	2.57	3.82	3.55	3.29	4.45	4.11	3.83
			sensible	2.01	1.92	1.83	2.66	2.54	2.43	3.19	3.04	2.92
	0.3	17.3	total	3.14	2.94	2.73	4.15	3.88	3.60	4.96	4.62	4.28
			sensible	2.09	2.00	1.90	2.81	2.69	2.56	3.41	3.26	3.11
	0.4	28.3	total	3.23	3.02	2.80	4.32	4.04	3.75	5.23	4.88	4.53
			sensible	2.13	2.03	1.93	2.89	2.76	2.63	3.54	3.38	3.22

MKT3-V400

2 row chilled water coil				100 L/s			150 L/s			200 L/s		
Air on DB/WB	W. flow L/s	P.D. kPa	Cooling kW	Entering water temp			Entering water temp			Entering water temp		
				6	7	8	6	7	8	6	7	8
23/17	0.15	14.5	total	2.12	1.94	1.77	2.59	2.37	2.16	2.89	2.65	2.41
			sensible	1.48	1.40	1.32	1.88	1.79	1.71	2.19	2.10	1.99
	0.2	23.7	total	2.27	2.09	1.90	2.86	2.62	2.38	3.25	2.98	2.70
			sensible	1.55	1.46	1.38	2.01	1.90	1.80	2.35	2.23	2.11
	0.25	35	total	2.37	2.18	1.99	3.03	2.78	2.53	3.49	3.20	2.91
			sensible	1.59	1.50	1.41	2.09	1.97	1.86	2.45	2.32	2.20
27/19	0.15	14.5	total	2.58	2.40	2.23	3.15	2.93	2.72	3.51	3.28	3.04
			sensible	1.81	1.74	1.66	2.33	2.23	2.15	2.71	2.61	2.51
	0.2	23.7	total	2.77	2.58	2.40	3.48	3.24	3.00	3.95	3.68	3.40
			sensible	1.90	1.82	1.73	2.47	2.37	2.26	2.90	2.77	2.66
	0.25	35	total	2.88	2.69	2.50	3.69	3.44	3.19	4.25	3.96	3.66
			sensible	1.95	1.86	1.78	2.56	2.45	2.34	3.03	2.90	2.77

1 row hot water coil

Air on DB	W. flow L/s	P.D. kPa	Heating kW	Entering water temp			Entering water temp			Entering water temp		
				50	65	80	50	65	80	50	65	80
15	0.03	2.5	heat	1.97	2.85	3.73	2.25	3.26	4.26	2.42	3.50	4.59
	0.06	7.8	heat	2.37	3.42	4.48	2.85	4.11	5.37	3.16	4.56	5.96
	0.09	15.7	heat	2.53	3.64	4.76	3.10	4.46	5.82	3.49	5.02	6.57
21	0.03	2.5	heat	1.73	2.50	3.38	1.87	2.86	3.86	2.01	3.08	4.17
	0.06	7.8	heat	1.95	2.99	4.03	2.35	3.59	4.85	2.61	4.00	5.40
	0.09	15.7	heat	2.08	3.18	4.29	2.55	3.90	5.25	2.88	4.40	5.93

MKT3-V400 (12Pa)

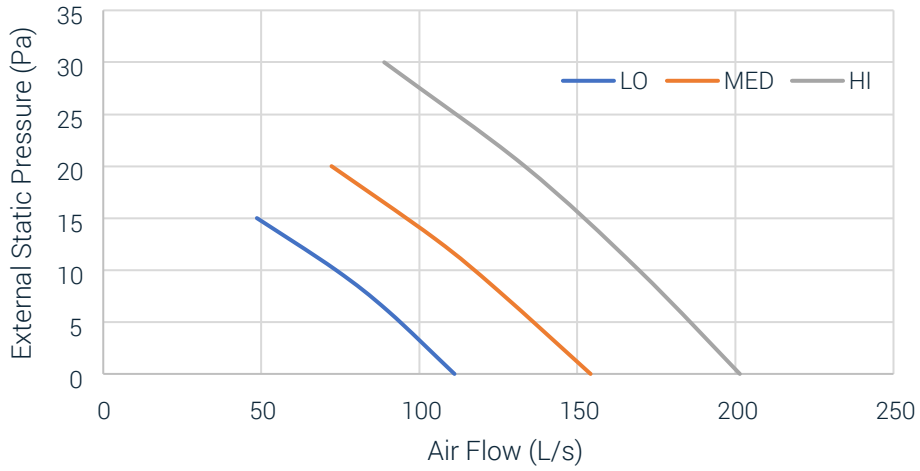

MKT3-V400 (30Pa)

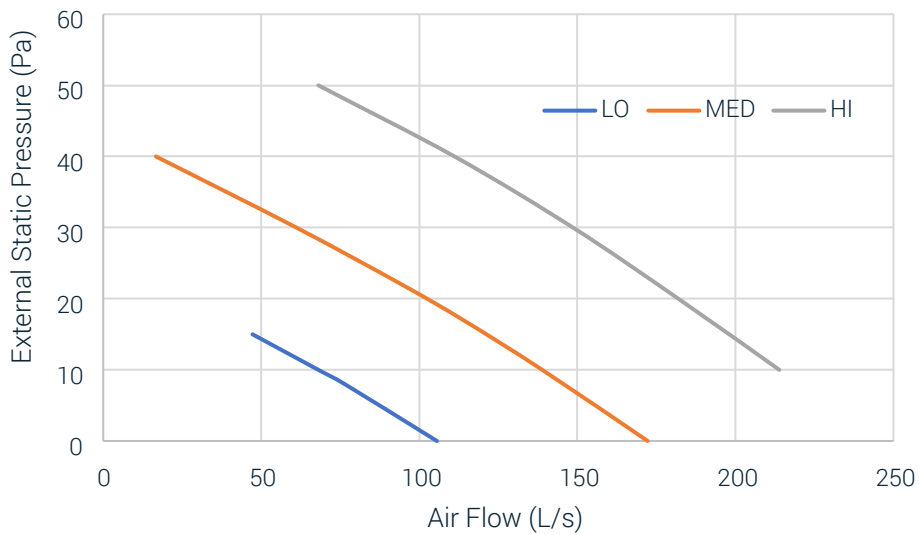

MKT3-V400 (50Pa)

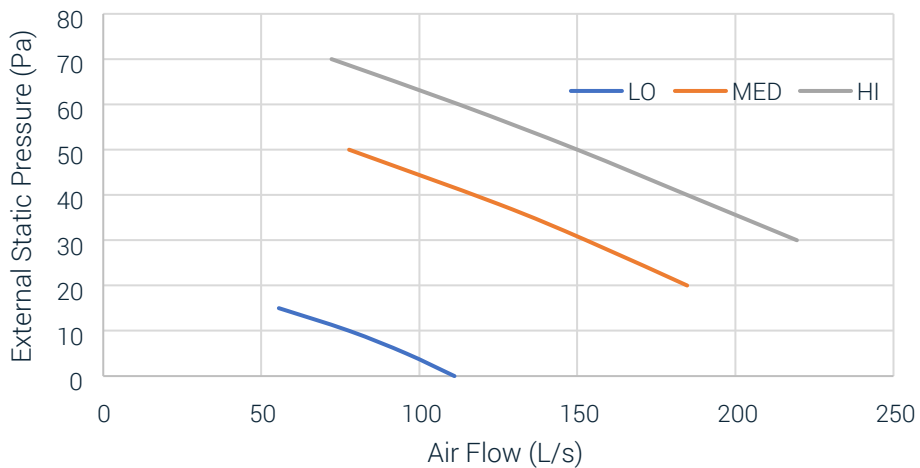

MKT4-V500

				Low Speed			Medium Speed			High Speed		
4 row chilled water coil				150 L/s			200 L/s			250 L/s		
Air on DB/WB	W. flow L/s	P.D. kPa	Cooling kW	Entering water temp			Entering water temp			Entering water temp		
				6	7	8	6	7	8	6	7	8
23/17	0.2	10.6	total	3.18	2.92	2.66	3.71	3.40	3.09	4.12	3.77	3.43
			sensible	2.20	2.08	1.96	2.63	2.50	2.36	3.01	2.85	2.70
	0.3	21.2	total	3.47	3.19	2.90	4.15	3.81	3.46	4.69	4.30	3.91
			sensible	2.33	2.20	2.07	2.83	2.68	2.52	3.25	3.08	2.91
	0.4	34.9	total	3.61	3.32	3.03	4.37	4.02	3.66	5.01	4.60	4.19
			sensible	2.40	2.26	2.12	2.93	2.77	2.61	3.40	3.21	3.03
27/19	0.2	10.6	total	3.88	3.61	3.35	4.52	4.21	3.89	5.01	4.66	4.32
			sensible	2.70	2.58	2.47	3.25	3.10	2.97	3.70	3.55	3.40
	0.3	21.2	total	4.22	3.94	3.66	5.05	4.71	4.36	5.71	5.32	4.93
			sensible	2.86	2.73	2.60	3.48	3.32	3.17	4.01	3.83	3.66
	0.4	34.9	total	4.40	4.11	3.81	5.32	4.97	4.61	6.10	5.69	5.28
			sensible	2.94	2.80	2.67	3.60	3.44	3.28	4.18	3.99	3.81

MKT3-V500

2 row chilled water coil				150 L/s			200 L/s			250 L/s		
Air on DB/WB	W. flow L/s	P.D. kPa	Cooling kW	Entering water temp			Entering water temp			Entering water temp		
				6	7	8	6	7	8	6	7	8
23/17	0.15	13.8	total	2.57	2.36	2.14	2.87	2.63	2.40	3.10	2.85	2.60
			sensible	1.87	1.78	1.69	2.18	2.08	1.97	2.42	2.31	2.20
	0.2	22.6	total	2.84	2.60	2.36	3.23	2.96	2.68	3.52	3.22	2.93
			sensible	1.99	1.89	1.78	2.33	2.22	2.10	2.60	2.47	2.34
	0.25	33.3	total	3.01	2.76	2.51	3.46	3.18	2.89	3.81	3.49	3.17
			sensible	1.07	1.96	1.85	2.44	2.31	2.18	2.73	2.59	2.45
27/19	0.15	13.8	total	3.13	2.77	2.70	3.50	3.34	3.03	3.77	3.82	3.28
			sensible	2.31	2.16	2.13	2.70	2.63	2.50	2.99	3.02	2.78
	0.2	22.6	total	3.45	3.22	2.98	3.93	3.66	3.38	4.28	3.98	3.68
			sensible	2.45	2.35	2.25	2.88	2.76	2.65	3.20	3.08	2.96
	0.25	33.3	total	3.66	3.42	3.17	4.22	3.93	3.64	4.64	4.32	4.00
			sensible	2.55	2.43	2.33	3.01	2.88	2.75	3.37	3.23	3.09

1 row hot water coil

Air on DB	W. flow L/s	P.D. kPa	Heating kW	Entering water temp			Entering water temp			Entering water temp		
				50	65	80	50	65	80	50	65	80
15	0.03	2.7	heat	2.26	3.27	4.28	2.43	3.52	4.61	2.56	3.69	4.83
	0.06	8.5	heat	2.86	4.13	5.40	3.18	4.59	6.00	3.41	4.92	6.43
	0.09	17	heat	3.11	4.48	5.87	3.51	5.05	6.61	3.80	5.47	7.15
21	0.03	2.7	heat	1.87	2.87	3.88	2.02	3.10	4.18	2.13	3.25	4.39
	0.06	8.5	heat	2.36	3.61	4.88	2.63	4.02	5.43	2.82	4.32	5.82
	0.09	17	heat	2.57	3.92	5.29	2.90	4.43	5.97	3.14	4.80	6.47

MKT3-V500 (12Pa)

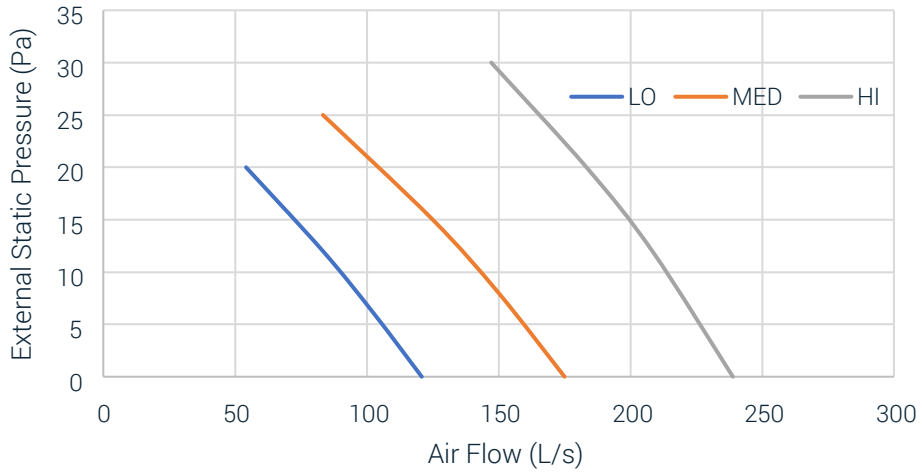

MKT3-V500 (30Pa)

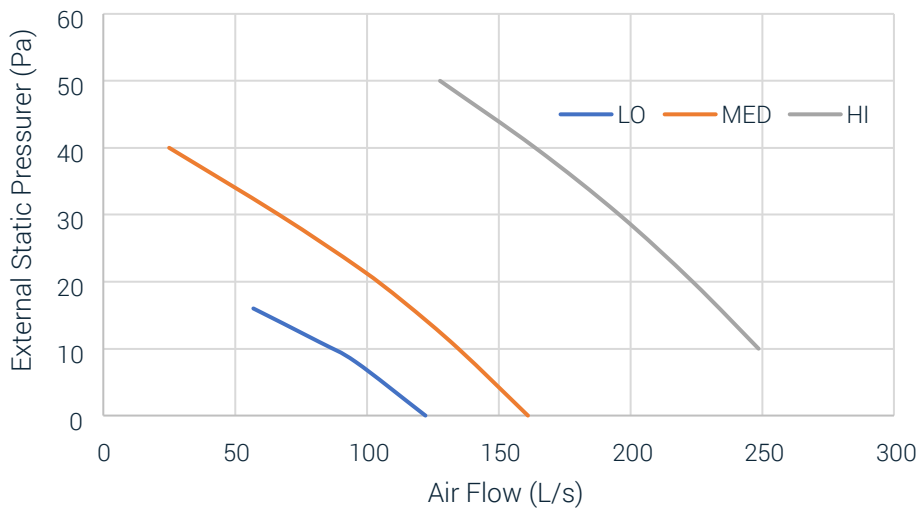

MKT3-V500 (50Pa)

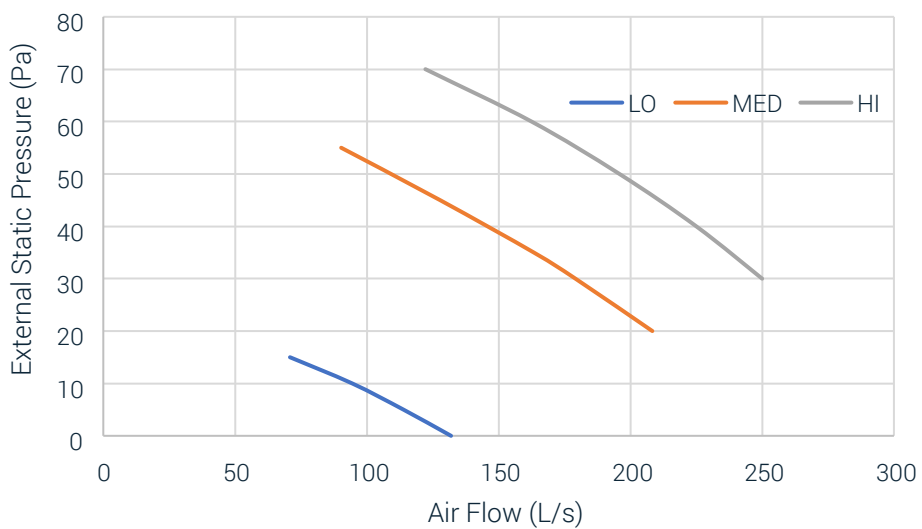

MKT4-V600

				Low Speed			Medium Speed			High Speed		
4 row chilled water coil				200 L/s			250 L/s			300 L/s		
Air on DB/WB	W. flow L/s	P.D. kPa	Cooling kW	Entering water temp			Entering water temp			Entering water temp		
				6	7	8	6	7	8	6	7	8
23/17	0.2	10.2	total	4.01	3.68	3.34	4.47	4.09	3.72	4.84	4.43	4.04
			sensible	2.82	2.67	2.52	3.22	3.05	2.89	3.57	3.40	3.22
	0.3	20.5	total	4.45	4.09	3.72	5.06	4.64	4.22	5.58	5.12	4.65
			sensible	3.02	2.85	2.68	3.49	3.29	3.11	3.90	3.70	3.49
	0.4	33.7	total	4.68	4.30	3.92	5.38	4.94	4.50	6.00	5.50	5.01
			sensible	3.12	2.95	2.77	3.63	3.43	3.23	4.09	3.87	3.64
27/19	0.2	10.2	total	4.88	4.54	4.20	5.43	5.05	4.68	5.88	5.48	5.08
			sensible	3.47	3.31	3.17	3.97	3.80	3.64	4.41	4.23	4.06
	0.3	20.5	total	5.42	5.05	4.68	6.16	5.74	5.32	6.79	6.32	5.85
			sensible	3.71	3.54	3.38	4.29	4.10	3.91	4.80	4.59	4.38
	0.4	33.7	total	5.69	5.31	4.93	6.55	6.11	5.67	7.30	6.81	6.31
			sensible	3.83	3.66	3.49	4.46	4.26	4.06	5.03	4.80	4.58

MKT3-V600

2 row chilled water coil				200 L/s			250 L/s			300 L/s		
Air on DB/WB	W. flow L/s	P.D. kPa	Cooling kW	Entering water temp			Entering water temp			Entering water temp		
				6	7	8	6	7	8	6	7	8
23/17	0.2	10.9	total	3.59	3.29	2.99	3.95	3.61	3.28	4.21	3.86	3.51
			sensible	2.57	2.44	2.30	2.90	2.75	2.61	3.17	3.02	2.87
	0.3	22.8	total	4.03	3.70	3.36	4.50	4.13	3.75	4.89	4.48	4.07
			sensible	2.77	2.62	2.47	3.14	2.97	2.81	3.46	3.28	3.10
	0.4	36.5	total	4.26	3.91	3.56	4.82	4.42	4.02	5.28	4.84	4.40
			sensible	2.87	2.71	2.55	3.28	3.11	2.93	3.64	3.44	3.25
27/19	0.2	10.9	total	4.37	4.01	3.76	4.80	4.63	4.13	5.13	4.77	4.43
			sensible	3.16	3.01	2.90	3.57	3.50	3.29	3.92	3.77	3.62
	0.3	22.8	total	4.90	4.57	4.23	5.48	5.11	4.73	5.95	5.54	5.13
			sensible	3.40	3.25	3.10	3.87	3.70	3.54	4.27	4.09	3.91
	0.4	36.5	total	5.19	4.54	4.49	5.87	5.47	5.07	6.43	5.99	5.55
			sensible	3.53	3.37	3.22	4.04	3.86	3.69	4.48	4.29	4.09

1 row hot water coil

Air on DB	W. flow L/s	P.D. kPa	Heating kW	Entering water temp			Entering water temp			Entering water temp		
				50	65	80	50	65	80	50	65	80
15	0.03	3.6	heat	2.65	3.82	4.99	2.78	4.00	5.23	2.88	4.14	5.41
	0.06	11.4	heat	3.49	5.03	6.58	3.76	5.43	7.08	3.98	5.73	7.48
	0.09	23.1	heat	3.86	5.56	7.27	4.22	6.07	7.93	4.50	6.47	8.45
21	0.03	3.6	heat	2.19	3.36	4.53	2.31	3.53	4.75	2.39	3.65	4.92
	0.06	11.4	heat	2.88	4.41	5.94	3.11	4.76	6.41	3.29	5.03	6.78
	0.09	23.1	heat	3.19	4.87	6.56	3.48	5.32	7.16	3.72	5.68	7.65

MKT3-V600 (12Pa)

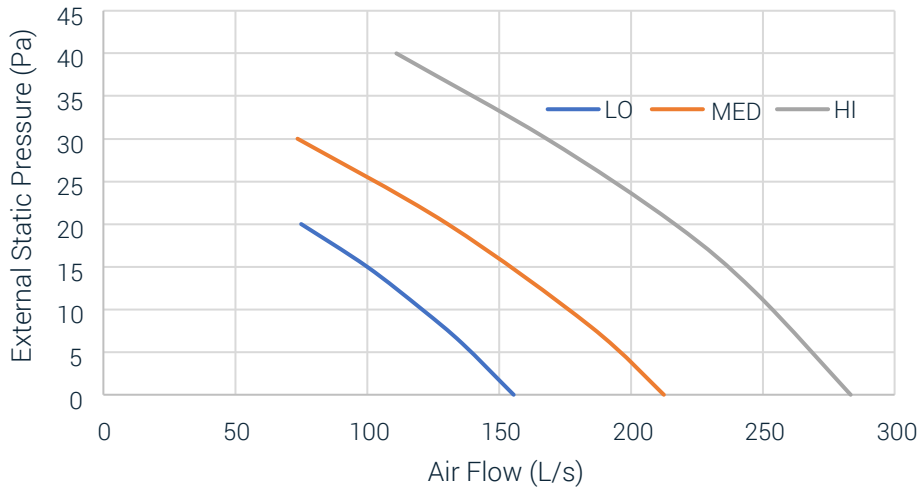

MKT3-V600 (30Pa)

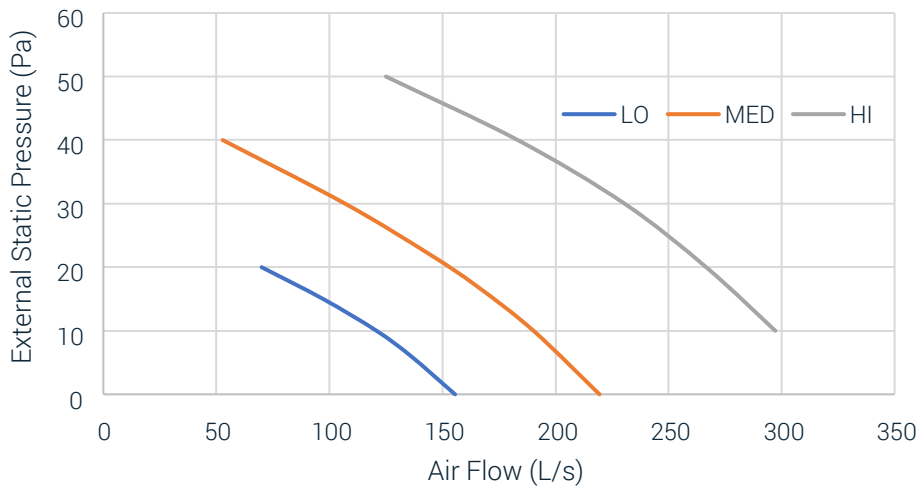

MKT3-V600 (50Pa)

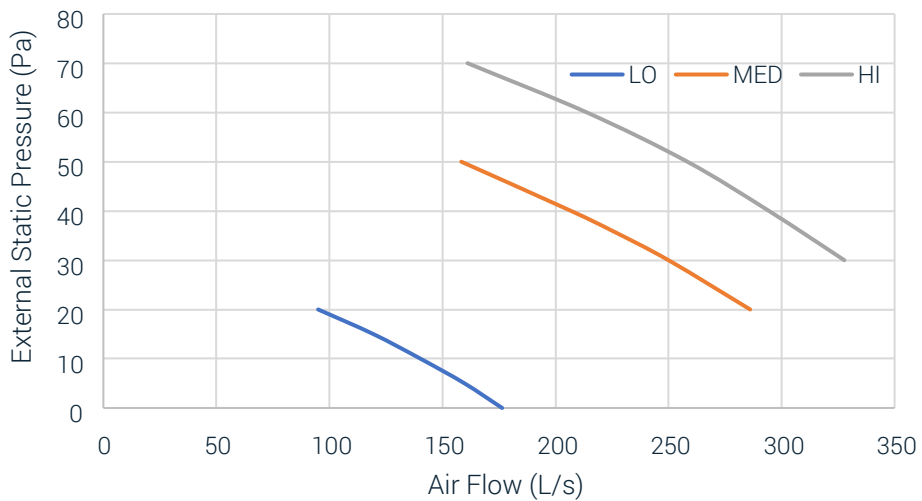

MKT4-V800

				Low Speed			Medium Speed			High Speed		
4 row chilled water coil				200 L/s			300 L/s			400 L/s		
Air on DB/WB	W. flow L/s	P.D. kPa	Cooling kW	Entering water temp			Entering water temp			Entering water temp		
				6	7	8	6	7	8	6	7	8
23/17	0.3	7.7	total	4.26	3.91	3.56	5.28	4.84	4.40	5.99	5.49	5.00
			sensible	2.93	2.77	2.62	3.78	3.60	3.39	4.45	4.23	4.02
	0.5	18.3	total	4.71	4.33	3.95	6.10	5.60	5.09	7.14	6.56	5.96
			sensible	3.14	2.96	2.78	4.15	3.92	3.69	4.96	4.69	4.43
	0.7	32.6	total	4.91	4.51	4.12	6.46	5.94	5.41	7.70	7.07	6.44
			sensible	3.23	3.04	2.86	4.32	4.07	3.83	5.21	4.92	4.64
27/19	0.3	7.7	total	5.18	4.83	4.48	6.43	5.98	5.54	7.29	6.78	6.29
			sensible	3.60	3.45	3.29	4.66	4.46	4.28	5.50	5.28	5.07
	0.5	18.3	total	5.74	5.36	4.97	7.42	6.92	6.42	8.70	8.11	7.51
			sensible	3.86	3.68	3.51	5.10	4.88	4.65	6.11	5.84	5.58
	0.7	32.6	total	5.97	5.58	5.19	7.88	7.35	6.83	9.38	8.76	8.12
			sensible	3.97	3.78	3.60	5.31	5.07	4.83	6.41	6.13	5.84

MKT3-V800

2 row chilled water coil				200 L/s			300 L/s			400 L/s		
Air on DB/WB	W. flow L/s	P.D. kPa	Cooling kW	Entering water temp			Entering water temp			Entering water temp		
				6	7	8	6	7	8	6	7	8
23/17	0.3	13.6	total	4.26	3.91	3.55	5.22	4.78	4.34	5.86	5.36	4.87
			sensible	2.93	2.77	2.61	3.72	3.54	3.34	4.32	4.10	3.89
	0.4	22.3	total	4.52	4.15	3.78	5.67	5.20	4.73	6.47	5.93	5.38
			sensible	3.05	2.87	2.71	3.93	3.72	3.51	4.59	4.35	4.11
	0.5	32.9	total	4.68	4.30	3.92	5.96	5.48	4.99	6.88	6.31	5.74
			sensible	3.12	2.95	2.77	4.06	3.84	3.62	4.77	4.51	4.26
27/19	0.3	13.6	total	5.18	4.83	4.47	6.36	5.91	5.47	7.13	6.62	6.13
			sensible	3.60	3.44	3.29	4.59	4.40	4.21	5.34	5.12	4.92
	0.4	22.3	total	5.50	5.14	4.76	6.91	6.44	5.96	7.88	7.34	6.79
			sensible	3.74	3.58	3.41	4.84	4.63	4.42	5.66	5.42	5.20
	0.5	32.9	total	5.70	5.32	4.94	7.27	6.78	6.28	8.39	7.81	7.24
			sensible	3.84	3.66	3.49	5.00	4.78	4.55	5.88	5.62	5.37

1 row hot water coil

Air on DB	W. flow L/s	P.D. kPa	Heating kW	Entering water temp			Entering water temp			Entering water temp		
				50	65	80	50	65	80	50	65	80
15	0.05	0.5	heat	3.87	5.62	7.38	4.32	6.27	8.24	4.58	6.65	8.73
	0.1	1.6	heat	4.97	7.18	9.41	5.89	8.51	11.15	6.48	9.38	12.27
	0.2	5.3	heat	5.66	8.16	10.68	6.99	10.08	13.20	7.92	11.43	14.96
21	0.05	0.5	heat	3.20	4.93	6.68	3.59	5.53	7.48	3.81	5.87	7.94
	0.1	1.6	heat	4.09	6.27	8.48	4.86	7.46	10.08	5.36	8.22	11.11
	0.2	5.3	heat	4.64	7.10	9.59	5.75	8.81	11.89	6.53	10.00	13.50

MKT3-V800 (12Pa)

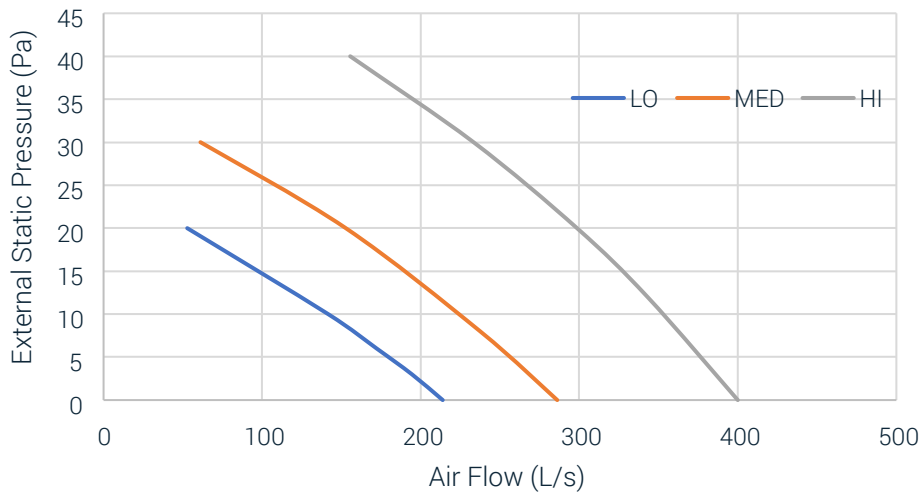

MKT3-V800 (30Pa)

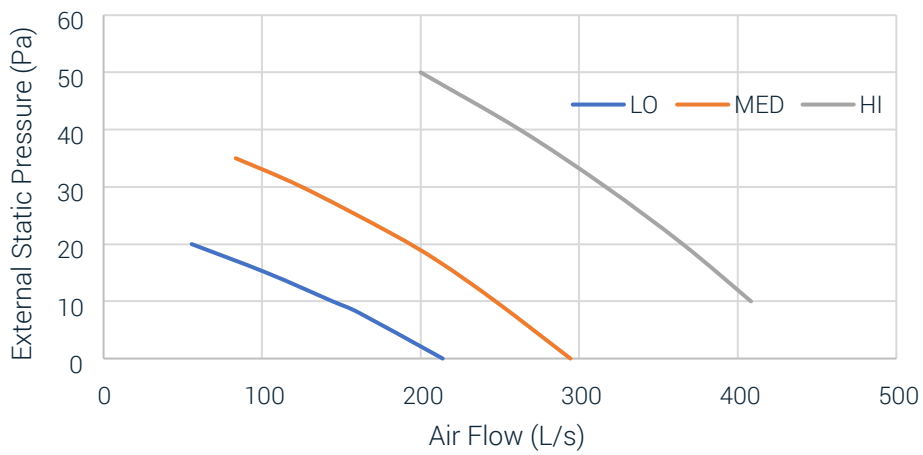

MKT3-V800 (50Pa)

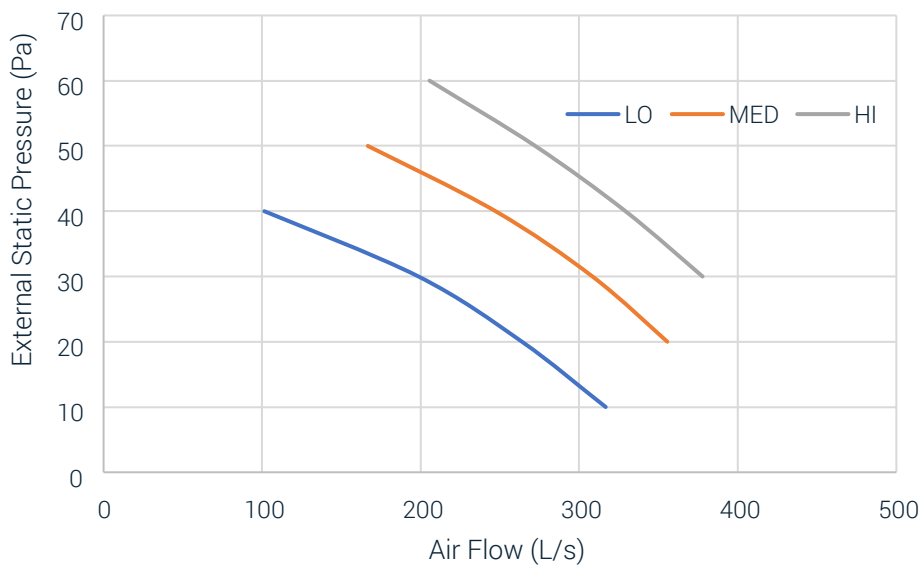

MKT4-V1000

				Low Speed			Medium Speed			High Speed		
4 row chilled water coil				300 L/s			400 L/s			500 L/s		
Air on DB/WB	W. flow L/s	P.D. kPa	Cooling kW	Entering water temp			Entering water temp			Entering water temp		
				6	7	8	6	7	8	6	7	8
23/17	0.3	8.3	total	5.49	5.03	4.57	6.24	5.71	5.20	6.82	6.26	5.72
			sensible	3.92	3.72	3.52	4.62	4.39	4.17	5.22	4.97	4.74
	0.5	19.8	total	6.32	5.81	5.29	7.43	6.81	6.20	8.33	7.63	6.94
			sensible	4.30	4.06	3.83	5.15	4.87	4.60	5.86	5.57	5.26
	0.7	35.6	total	6.70	6.16	5.61	8.01	7.35	6.70	9.08	8.34	7.58
			sensible	4.47	4.22	3.97	5.41	5.11	4.82	6.22	5.89	5.54
27/19	0.3	8.3	total	6.68	6.21	5.75	7.58	7.06	6.55	8.30	7.74	7.20
			sensible	4.83	4.62	4.43	5.70	5.48	5.26	6.45	6.21	5.97
	0.5	19.8	total	7.70	7.18	6.86	9.04	8.43	7.81	10.14	9.44	8.74
			sensible	5.28	5.05	4.98	6.33	6.06	5.79	7.23	6.93	6.63
	0.7	35.6	total	8.16	7.62	7.07	9.75	9.10	8.44	11.07	10.32	9.56
			sensible	5.49	5.24	5.00	6.66	6.36	6.06	7.65	7.32	6.98

MKT3-V1000

2 row chilled water coil				300 L/s			400 L/s			500 L/s		
Air on DB/WB	W. flow L/s	P.D. kPa	Cooling kW	Entering water temp			Entering water temp			Entering water temp		
				6	7	8	6	7	8	6	7	8
23/17	0.3	14.6	total	5.37	4.92	4.47	6.06	5.54	5.04	6.55	5.99	5.46
			sensible	3.82	3.63	3.42	4.46	4.23	4.02	4.96	4.72	4.40
	0.4	23.7	total	5.83	5.35	4.86	6.69	6.13	5.57	7.33	6.71	6.09
			sensible	4.03	3.81	3.60	4.74	4.49	4.24	5.30	5.02	4.76
	0.5	35.2	total	6.12	5.62	5.12	7.11	6.52	5.93	7.86	7.20	6.54
			sensible	4.16	3.93	3.71	4.93	4.66	4.39	5.53	5.24	4.95
27/19	0.3	14.6	total	6.54	6.08	5.63	7.37	6.85	6.35	7.96	7.42	6.88
			sensible	4.71	4.51	4.32	5.50	5.28	5.07	6.13	5.90	5.67
	0.4	23.7	total	7.10	6.61	6.13	8.15	7.59	7.02	8.93	8.30	7.67
			sensible	4.95	4.74	4.53	5.84	5.59	5.35	6.54	6.27	6.01
	0.5	35.2	total	7.46	6.95	6.45	8.67	8.08	7.48	9.58	8.92	8.25
			sensible	5.11	4.89	4.66	6.06	5.80	5.54	6.82	6.53	6.25

1 row hot water coil

Air on DB	W. flow L/s	P.D. kPa	Heating kW	Entering water temp			Entering water temp			Entering water temp		
				50	65	80	50	65	80	50	65	80
15	0.05	0.6	heat	4.40	6.38	8.37	4.67	6.77	8.88	4.85	7.03	9.21
	0.1	1.7	heat	5.98	8.64	11.32	6.60	9.56	12.50	7.04	10.19	13.33
	0.2	5.2	heat	7.08	10.21	13.36	8.07	11.63	15.22	8.80	12.69	16.61
21	0.05	0.6	heat	3.65	5.62	7.60	3.89	5.98	8.08	4.04	6.21	8.39
	0.1	1.7	heat	4.93	7.57	10.22	5.46	8.38	11.31	5.83	8.95	12.08
	0.2	5.2	heat	5.83	8.92	12.03	6.65	10.18	13.73	7.27	11.12	15.01

MKT3-V1000 (12Pa)

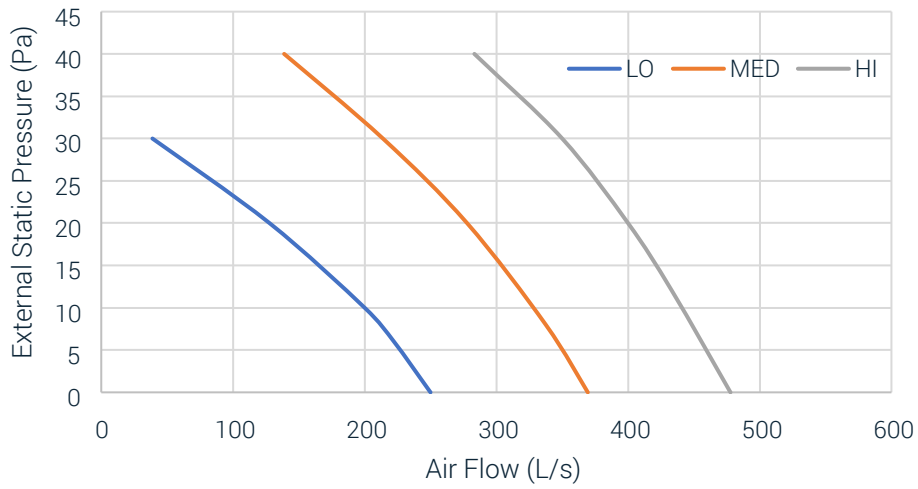

MKT3-V1000 (30Pa)

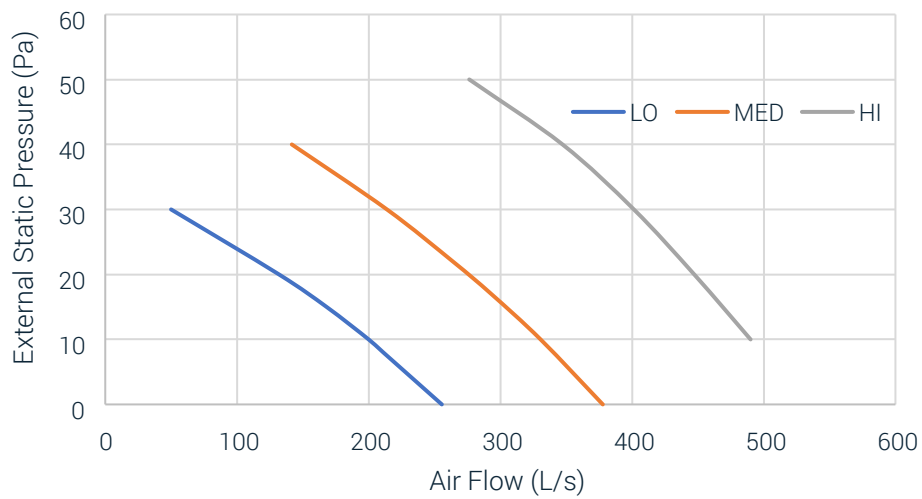

MKT3-V1000 (50Pa)

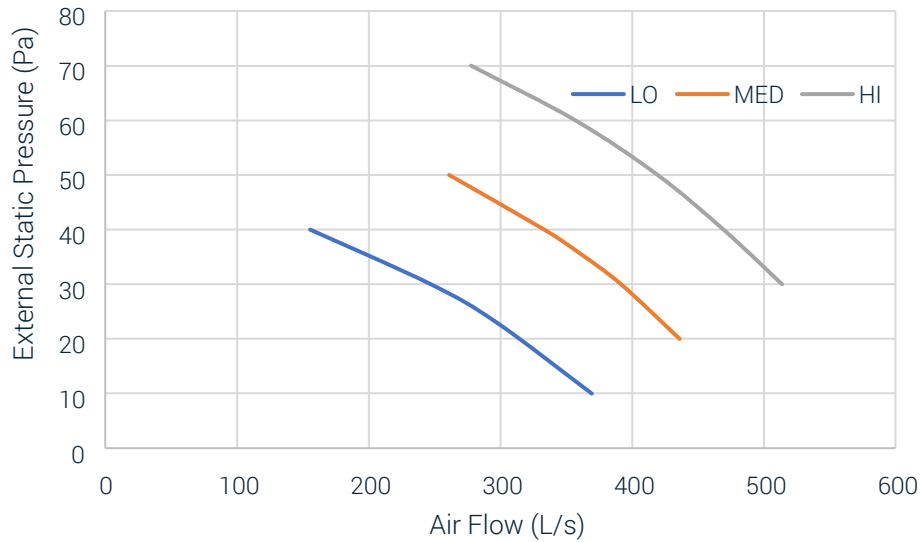

MKT4-V1200

				Low Speed			Medium Speed			High Speed		
4 row chilled water coil				400 L/s			500 L/s			600 L/s		
Air on DB/WB	W. flow L/s	P.D. kPa	Cooling kW	Entering water temp			Entering water temp			Entering water temp		
				6	7	8	6	7	8	6	7	8
23/17	0.3	9.7	total	6.75	6.18	5.63	7.39	6.78	6.19	7.90	7.27	6.65
			sensible	4.96	4.72	4.47	5.62	5.35	5.09	6.19	5.90	5.62
	0.5	23.1	total	8.01	7.35	6.68	9.00	8.25	7.49	9.81	8.98	8.15
			sensible	5.53	5.23	4.93	6.34	6.00	5.67	7.03	6.66	6.13
	0.7	41.4	total	8.59	7.90	7.19	9.81	9.00	8.19	10.83	9.93	9.03
			sensible	5.79	5.47	5.15	6.69	6.33	5.96	7.49	7.07	6.67
27/19	0.3	9.7	total	8.20	7.64	7.09	8.99	8.39	7.81	9.63	9.00	8.39
			sensible	6.12	5.87	5.64	6.94	6.69	6.43	7.66	7.39	7.11
	0.5	23.1	total	9.74	9.08	8.41	10.96	10.20	9.43	11.94	11.10	10.27
			sensible	6.79	6.49	6.20	7.79	7.45	7.12	8.65	8.30	7.94
	0.7	41.4	total	10.47	9.76	9.06	11.94	11.14	10.32	13.19	12.29	11.38
			sensible	7.12	6.79	6.48	8.23	7.86	7.51	9.20	8.80	8.41

MKT3-V1200

2 row chilled water coil				400 L/s			500 L/s			600 L/s		
Air on DB/WB	W. flow L/s	P.D. kPa	Cooling kW	Entering water temp			Entering water temp			Entering water temp		
				6	7	8	6	7	8	6	7	8
23/17	0.3	17.6	total	6.48	5.96	5.39	7.03	6.44	5.87	7.46	6.85	6.25
			sensible	4.73	4.49	4.26	5.29	5.03	4.78	5.76	5.49	5.22
	0.4	28.9	total	7.15	6.55	5.95	7.86	7.20	6.53	8.43	7.70	6.99
			sensible	5.03	4.76	4.50	5.65	5.36	5.07	6.18	5.86	5.56
	0.5	42.4	total	7.58	6.95	6.32	8.42	7.72	7.01	9.10	8.33	7.56
			sensible	5.22	4.94	4.66	5.90	5.58	5.27	6.47	6.13	5.80
27/19	0.3	17.6	total	7.89	7.33	6.79	8.56	7.97	7.40	9.09	8.48	7.88
			sensible	5.84	5.60	5.37	6.54	6.29	6.04	7.13	6.87	6.61
	0.4	28.9	total	8.70	8.10	7.49	9.57	8.90	8.22	10.26	9.53	8.81
			sensible	6.19	5.92	5.67	6.97	6.68	6.40	7.63	7.32	7.02
	0.5	42.4	total	9.24	8.61	7.97	10.26	9.55	8.84	11.09	10.31	9.53
			sensible	6.43	6.15	5.87	7.27	6.96	6.65	7.99	7.65	7.32

1 row hot water coil

Air on DB	W. flow L/s	P.D. kPa	Heating kW	Entering water temp			Entering water temp			Entering water temp		
				50	65	80	50	65	80	50	65	80
15	0.05	0.6	heat	5.04	7.28	9.53	5.23	7.55	9.87	5.36	7.74	10.12
	0.1	2.0	heat	7.75	10.46	13.69	7.74	11.17	14.62	8.12	11.71	15.32
	0.2	6.2	heat	8.94	12.87	16.84	9.80	14.12	18.47	10.49	15.11	19.76
21	0.05	0.6	heat	4.19	6.43	8.67	4.35	6.67	8.99	4.47	6.84	9.22
	0.1	2.0	heat	5.99	9.18	12.38	6.41	9.82	13.24	6.73	10.30	13.90
	0.2	6.2	heat	7.36	11.25	15.18	8.08	12.36	16.68	8.66	13.24	17.87

MKT3-V1200 (12Pa)

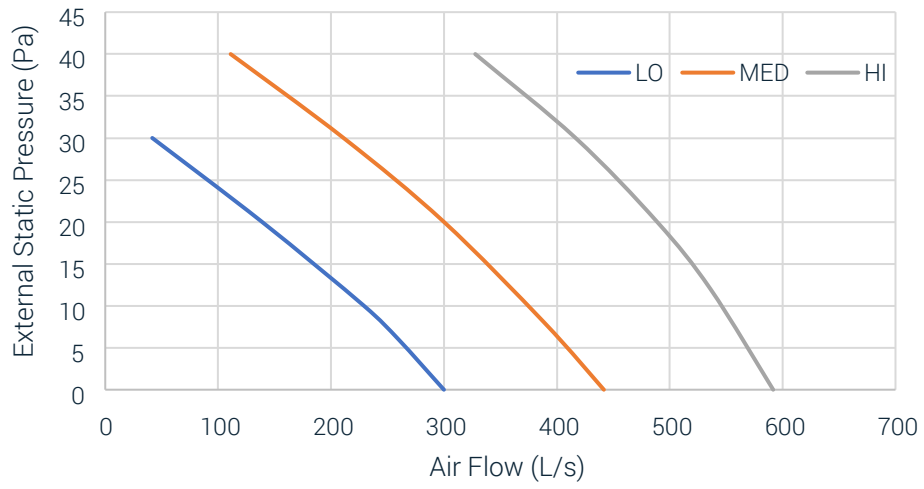

MKT3-V1200 (30Pa)

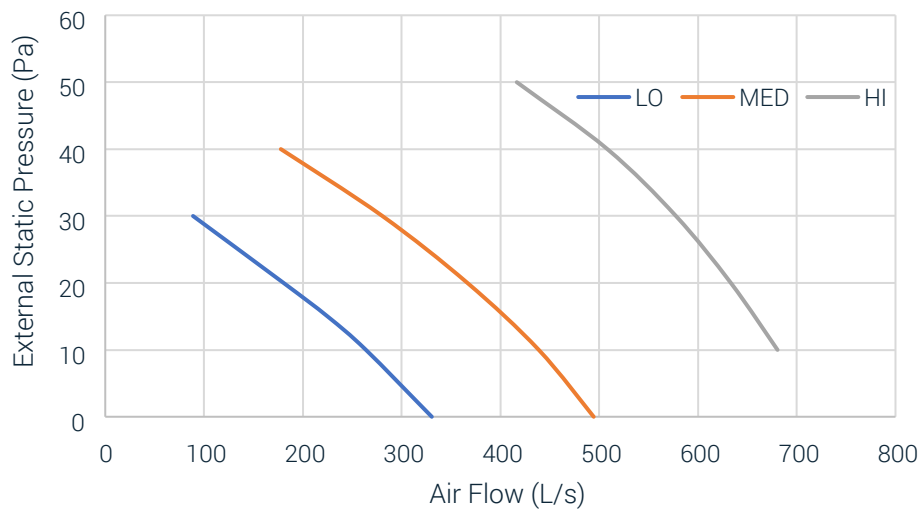

MKT3-V1200 (50Pa)

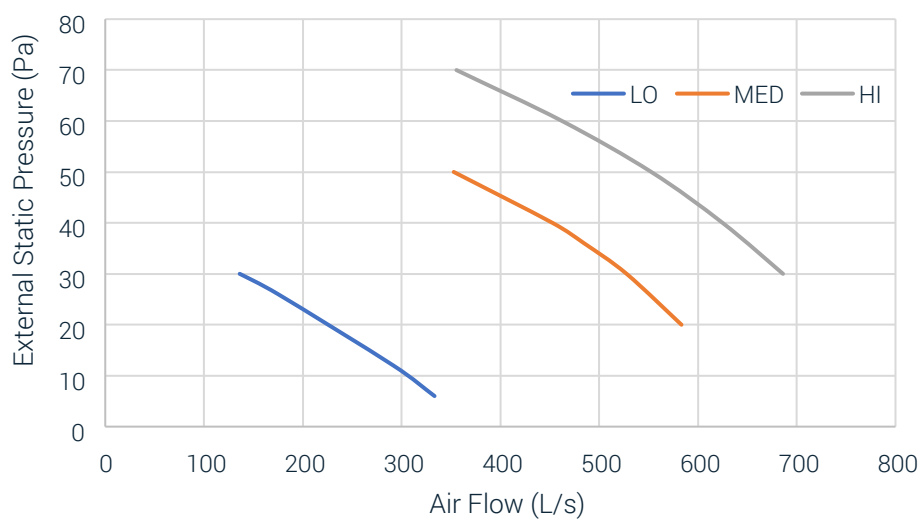

MKT Dimensions

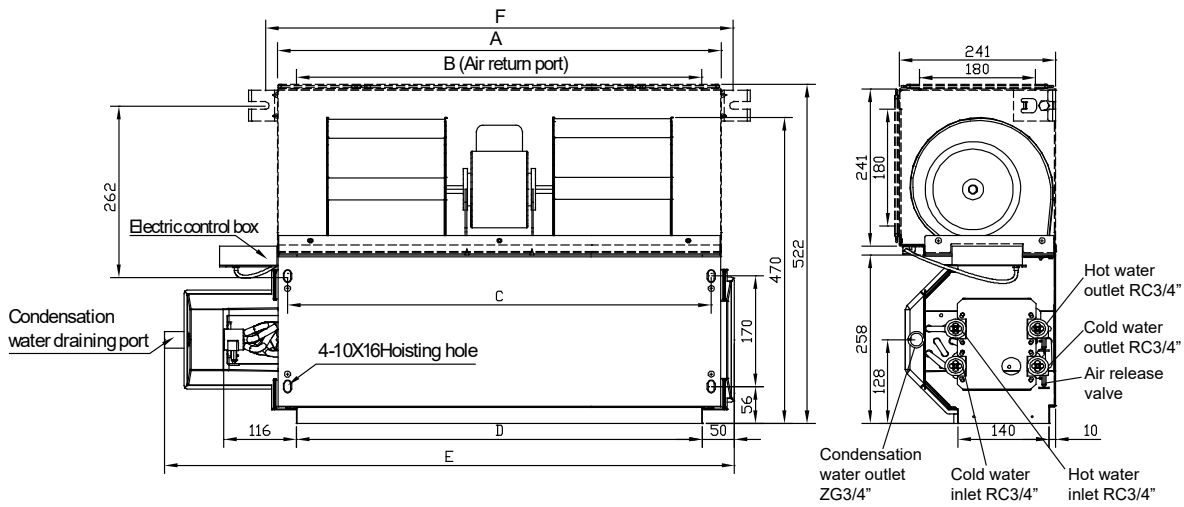

Model	200	300	400/500	600	800	1000	1200
A	545	645	745	965	1265	1370	1660
B	485	585	685	905	1205	1310	1600
C	513	613	713	933	1233	1338	1628
D	485	585	685	905	1205	1310	1600
E	741	841	941	1161	1461	1566	1856
F	583	683	783	1003	1303	1408	1698

Note:

- The above figures for a standard model only
- The broken lines in the above drawing illustrate the dimensions of return air box. (Return air inlet may be configured either from below or rear).
- Units with return air plenum are standard, and units without return air plenum can be customised.

MKT Space Requirements

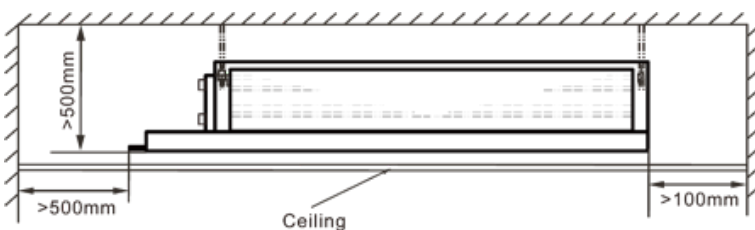
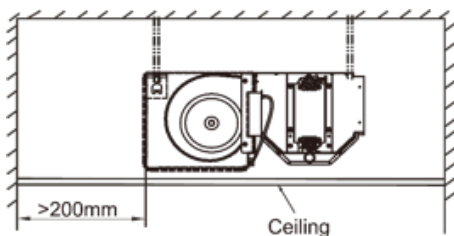

MKT Sound Levels

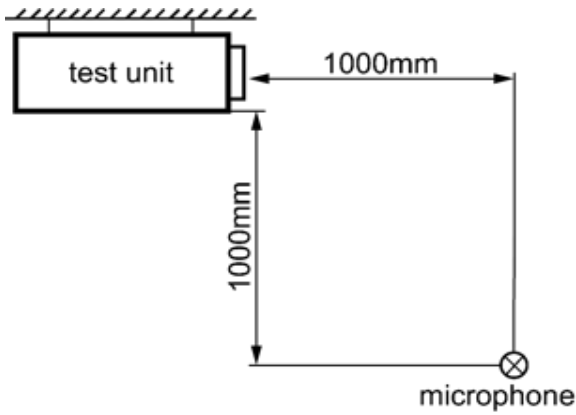

As measured with a free inlet and outlet in a semi-anechoic chamber 1m below and 1m to the front of the unit.

MKT3		V200	V300	V400	V500
0Pa (H/M/L)	dB(A)	38 / 28 / 23	36 / 29 / 21	38 / 32 / 24	44 / 36 / 28
15Pa (H/M/L)	dB(A)	37 / 26 / 22	34 / 28 / 20	37 / 31 / 24	43 / 36 / 27
30Pa (H/M/L)	dB(A)	42 / 32 / 25	40 / 30 / 24	43 / 36 / 28	47 / 38 / 30
50Pa (H/M/L)	dB(A)	44 / 34 / 25	44 / 36 / 27	46 / 40 / 31	48 / 42 / 33

MKT3		V600	V800	V1000	V1200
0Pa (H/M/L)	dB(A)	46 / 39 / 30	45 / 36 / 28	48 / 41 / 31	49 / 42 / 32
15Pa (H/M/L)	dB(A)	45 / 38 / 29	44 / 35 / 27	47 / 39 / 29	47 / 40 / 30
30Pa (H/M/L)	dB(A)	48 / 40 / 31	46 / 37 / 28	47 / 39 / 31	49 / 42 / 33
50Pa (H/M/L)	dB(A)	49 / 40 / 31	48 / 40 / 32	49 / 42 / 33	52 / 45 / 37

MKT4		V200	V300	V400	V500
0Pa (H/M/L)	dB(A)	37 / 27 / 22	40 / 32 / 25	41 / 34 / 26	45 / 37 / 30
15Pa (H/M/L)	dB(A)	36 / 25 / 21	37 / 31 / 24	40 / 33 / 26	43 / 37 / 29
30Pa (H/M/L)	dB(A)	41 / 31 / 24	43 / 33 / 28	46 / 38 / 30	48 / 38 / 32
50Pa (H/M/L)	dB(A)	43 / 34 / 24	48 / 40 / 31	49 / 41 / 34	49 / 43 / 35

MKT4		V600	V800	V1000	V1200
0Pa (H/M/L)	dB(A)	46 / 39 / 31	47 / 39 / 32	50 / 43 / 33	51 / 44 / 34
15Pa (H/M/L)	dB(A)	45 / 38 / 30	47 / 38 / 32	49 / 41 / 32	49 / 42 / 33
30Pa (H/M/L)	dB(A)	48 / 40 / 31	48 / 40 / 32	49 / 41 / 33	51 / 44 / 36
50Pa (H/M/L)	dB(A)	49 / 42 / 33	51 / 43 / 36	51 / 44 / 35	54 / 47 / 40

Advantage Range (Low Profile)

IMDL

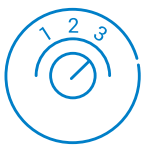

3 Speed Fan Motor



Easy Clean Plastic Drain



Electric Heating



Opposite Hand

Advantage Range (IMDL) Specifications



Model	IMDL 40	IMDL 60	IMDL 90	IMDL 130
Nominal Air Flow (l/s) *	200	330	480	650
Fan Type	Forward curved centrifugal double inlet double width			
No. of Fan Scrolls	1	2	2	3
Motor Type	Three speed, direct drive			
Power Source **	1 Phase 230 Volt AC 50 Hz			
No. of Motors	1	1	1	2
Motor Rating (W)	50	75	150	75 + 150
Full Load Amps (A) ***	0.6	0.7	1.4	0.7 + 1.4 (2.1)
Optional Electric Heating (kW)	1.5	2.0	3.0	4.0
Electric Heat Current (A)	6.6	8.8	13.2	17.6
Heat Exchanger Type	Aluminium corrugated plate fins to expanded rifled copper tube			
Cooling/Heating Medium	Chilled Water / Hot Water or Electric Heat			
Finish	Zinc galvanised steel			
Test Pressure	2100 kPa			
Connection Sizes Cooling Coil (mm)	Ø 20 (¾" BSP)	Ø 20 (¾" BSP)	Ø 25 (1" BSP)	Ø 25 (1" BSP)
Connection Sizes Heating Coil (mm)	Ø 15 (½" BSP)			
Air Filter Type	G2 / EU2 Washable			
No. of Air Filters	1	1	1	2
Air Filter Size (mm)	545 x 234 x 13	795 x 234 x 13	1045 x 243 x 13	725 x 243 x 13
Weight Incl. Water (kg)	25	34	46	67
Nett Dry Weight (kg)	24	32	42	62
Shipping Weight (kg)	25	34	45	65

* with no filters fitted and with a dry coil surface

** Voltage fluctuation limits 200-252V

*** Fan only, excluding Electric Heating

Cooling and Heating Coil options:

4 Row Cooling only

3 Row Cooling + 1 Row Heating

4 Row Cooling plus Electric Heating

IMDL 40H-4

				Low Air flow			Medium Air flow			Nominal Air flow		
4 row chilled water coil				100 L/s			150 L/s			200 L/s		
Air on DB/WB	W. flow L/s	P.D. kPa	Cooling kW	Entering water temp			Entering water temp			Entering water temp		
				6	7	8	6	7	8	6	7	8
23/17	0.15	6.7	total	2.6	2.4	2.2	3.6	3.3	3.0	3.9	3.6	3.3
			sensible	1.6	1.5	1.4	2.3	2.2	2.1	2.6	2.5	2.4
	0.25	16.7	total	2.9	2.6	2.4	4.1	3.8	3.5	4.6	4.2	3.9
			sensible	1.7	1.6	1.5	2.6	2.4	2.3	2.9	2.7	2.6
	0.35	30.5	total	3.0	2.7	2.5	4.4	4.1	3.7	4.9	4.6	4.2
			sensible	1.8	1.7	1.6	2.7	2.5	2.4	3.0	2.9	2.7
27/19	0.15	6.7	total	3.3	3.1	2.9	4.1	3.8	3.5	4.7	4.4	4.1
			sensible	2.0	1.9	1.8	2.6	2.5	2.4	3.2	3.1	2.9
	0.25	16.7	total	3.5	3.3	3.1	4.6	4.3	4.0	5.6	5.2	4.8
			sensible	2.1	2.0	1.9	2.9	2.7	2.6	3.5	3.4	3.2
	0.35	30.5	total	3.6	3.4	3.2	4.9	4.5	4.2	6.0	5.6	5.2
			sensible	2.2	2.1	2.0	3.0	2.8	2.7	3.7	3.5	3.4

IMDL 40H-3/1

3 row chilled water coil				100 L/s			150 L/s			200 L/s		
Air on DB/WB	W. flow L/s	P.D. kPa	Cooling kW	Entering water temp			Entering water temp			Entering water temp		
				6	7	8	6	7	8	6	7	8
23/17	0.1	5.4	total	2.1	2.0	1.8	2.5	2.3	2.1	2.8	2.5	2.3
			sensible	1.4	1.4	1.3	1.8	1.7	1.6	2.1	2.0	1.9
	0.2	18.8	total	2.5	2.3	2.1	3.1	2.9	2.6	3.6	3.3	3.0
			sensible	1.6	1.5	1.4	2.0	1.9	1.8	2.5	2.3	2.2
	0.25	27.9	total	2.6	2.4	2.1	3.3	3.0	2.7	3.8	3.5	3.2
			sensible	1.6	1.5	1.4	2.1	2.0	1.9	2.5	2.4	2.3
27/19	0.1	5.4	total	2.6	2.4	2.2	3.0	2.8	2.6	3.4	3.1	2.9
			sensible	1.8	1.7	1.6	2.2	2.1	2.0	2.7	2.6	2.5
	0.2	18.8	total	3.1	2.8	2.6	3.7	3.5	3.2	4.4	4.1	3.8
			sensible	2.0	1.9	1.8	2.5	2.4	2.3	3.1	2.9	2.8
	0.25	27.9	total	3.1	2.9	2.7	4.0	3.8	3.5	4.7	4.3	4.0
			sensible	2.0	1.9	1.8	2.6	2.5	2.4	3.1	3.0	2.9

1 row hot water coil

Air on DB	W. flow L/s	P.D. kPa	Heating kW	Entering water temp			Entering water temp			Entering water temp		
				50	65	80	50	65	80	50	65	80
15	0.04	6.4	heat	1.8	2.6	3.4	2.1	3.0	3.9	2.3	3.4	4.4
	0.07	17.4	heat	2.0	2.9	3.8	2.4	3.5	4.5	2.7	3.9	5.0
	0.1	33	heat	2.1	3.1	4.0	2.6	3.7	4.8	2.9	4.1	5.4
21	0.04	6.4	heat	1.5	2.3	3.0	1.8	2.6	3.5	2.0	3.0	4.0
	0.07	17.4	heat	1.7	2.6	3.4	2.0	3.0	4.0	2.3	3.5	4.6
	0.1	33	heat	1.8	2.7	3.7	2.1	3.2	4.3	2.4	3.7	5.0

Performance Data

IMDL 40H

Air Handling

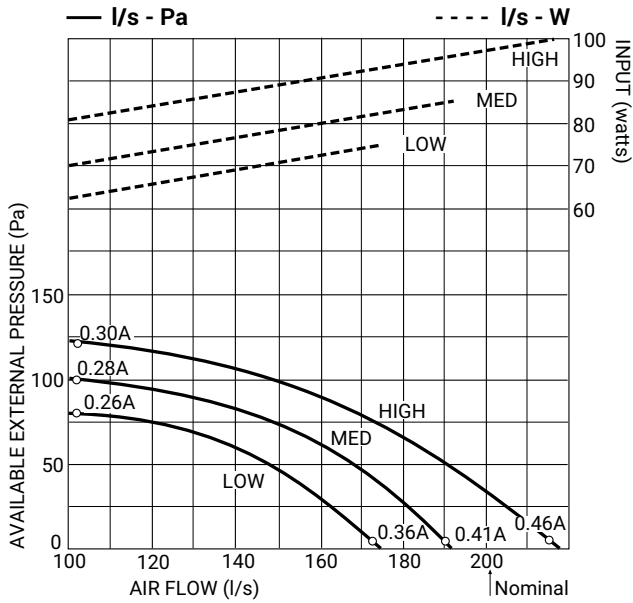

Note:

1. Airflows given are for a standard unit with rectangular air spigot and no filter installed.
2. Airflows are for dry coil. Reduce airflow by 10% in high moisture removal conditions.
3. In a free blow application, beware of exceeding indoor fan motor's full load amp limit.
4. Refer to page 70 for filter pressure drop.

Dimensions

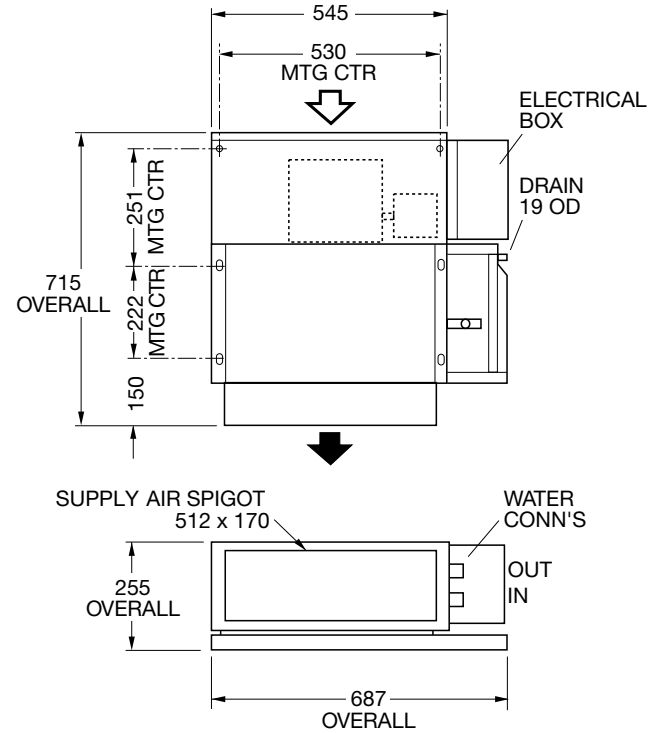

Sound Levels

Supply Air Outlet

Fan Speed	Sound Pressure Levels (SPL) (dB)						
	dB(A)	Octave Band Centre Frequency (Hz)					
		125	250	500	1K	2K	4K
Low	40	51	45	35	26	20	13
Med	42	52	48	38	29	23	17
High	45	57	50	40	31	25	19

Return Air Inlet + Case Breakout

dB(A)	Sound Pressure Levels (SPL) (dB)					
	125	250	500	1K	2K	4K
49	55	51	47	43	38	30
51	54	54	50	46	41	34
54	59	57	52	49	44	37

Sound levels are specified as in-situ conditions. For more information and adjustment factors for your specific installation please find supplementary booklets under the relevant units on our website www.temperzone.com

IMDL 60H-4

				Low Air flow			Medium Air flow			Nominal Air flow		
4 row chilled water coil				250 L/s			300 L/s			330 L/s		
Air on DB/WB	W. flow L/s	P.D. kPa	Cooling kW	Entering water temp			Entering water temp			Entering water temp		
				6	7	8	6	7	8	6	7	8
23/17	0.15	8.5	total	4.9	4.5	4.1	5.2	4.8	4.4	5.4	5.0	4.6
			sensible	3.3	3.1	3.0	3.6	3.5	3.3	3.9	3.7	3.5
	0.22	17.1	total	5.6	5.2	4.7	6.1	5.6	5.1	6.4	5.9	5.4
			sensible	3.6	3.4	3.2	4.0	3.8	3.6	4.2	4.0	3.8
	0.3	29.4	total	6.1	5.6	5.1	6.7	6.2	5.7	7.1	6.6	6.0
			sensible	3.8	3.6	3.4	4.2	4.0	3.8	4.5	4.3	4.1
27/19	0.15	8.5	total	6.0	5.6	5.2	6.4	6.0	5.6	6.6	6.2	5.7
			sensible	4.1	3.9	3.8	4.5	4.4	4.2	4.8	4.6	4.4
	0.22	17.1	total	6.9	6.4	6.0	7.5	7.0	6.5	7.8	7.3	6.8
			sensible	4.4	4.2	4.1	4.9	4.8	4.6	5.2	5.0	4.8
	0.3	29.4	total	7.5	7.0	6.5	8.3	7.7	7.2	8.7	8.1	7.5
			sensible	4.7	4.5	4.3	5.2	5.0	4.8	5.6	5.3	5.1

IMDL 60H-3/1

3 row chilled water coil				250 L/s			300 L/s			330 L/s		
Air on DB/WB	W. flow L/s	P.D. kPa	Cooling kW	Entering water temp			Entering water temp			Entering water temp		
				6	7	8	6	7	8	6	7	8
23/17	0.11	8.2	total	3.7	3.4	3.1	3.9	3.6	3.2	4.0	3.7	3.3
			sensible	2.8	2.7	2.6	3.1	3.0	2.9	3.3	3.2	3.1
	0.17	18.1	total	4.5	4.0	3.7	4.8	4.4	4.0	5.0	4.6	4.1
			sensible	3.1	3.0	2.8	3.4	3.3	3.1	3.7	3.5	3.3
	0.23	30.6	total	4.9	4.5	4.1	5.3	4.9	4.4	5.6	5.1	4.6
			sensible	3.3	3.1	3.0	3.7	3.5	3.3	3.9	3.7	3.5
27/19	0.11	8.2	total	4.5	4.2	3.9	4.7	4.4	4.0	4.8	4.5	4.1
			sensible	3.5	3.4	3.3	3.9	3.8	3.6	4.1	4.0	3.9
	0.17	18.1	total	5.4	5.0	4.6	5.8	5.4	5.0	6.0	5.5	5.1
			sensible	3.9	3.7	3.6	4.3	4.1	4.0	4.5	4.4	4.2
	0.23	30.6	total	6.0	5.5	5.1	6.5	6.0	5.5	6.7	6.3	5.8
			sensible	4.1	3.9	3.8	4.5	4.4	4.2	4.8	4.6	4.4

1 row hot water coil

Air on DB	W. flow L/s	P.D. kPa	Heating kW	Entering water temp			Entering water temp			Entering water temp		
				50	65	80	50	65	80	50	65	80
15	0.04	8.1	heat	3.0	4.3	5.5	3.2	4.6	6.0	3.3	4.7	6.2
	0.06	16.8	heat	3.4	4.9	6.4	3.6	5.2	6.8	3.8	5.4	7.0
	0.08	28.1	heat	3.7	5.3	6.9	3.9	5.7	7.3	4.1	5.8	7.6
21	0.04	8.1	heat	2.5	3.8	5.1	2.7	4.1	5.4	2.8	4.2	5.7
	0.06	16.8	heat	2.8	4.3	5.8	3.0	4.6	6.2	3.2	4.8	6.4
	0.08	28.1	heat	3.1	4.6	6.2	3.3	5.0	6.7	3.4	5.2	6.9

Performance Data

IMDL 60H

Air Handling

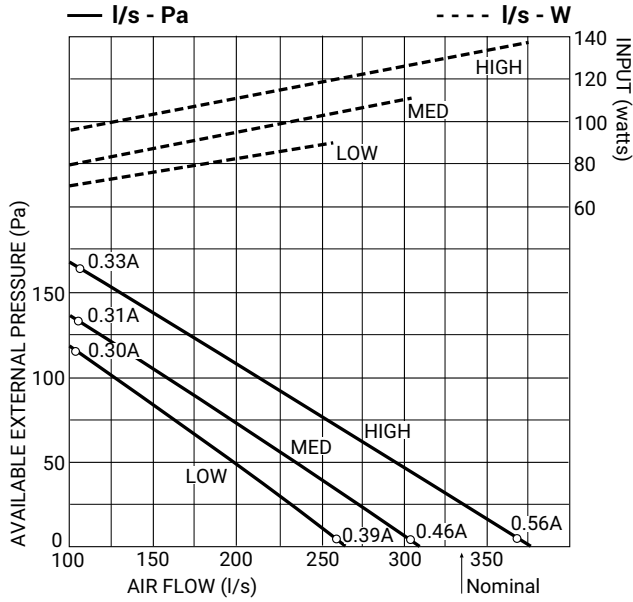

Note:

1. Airflows given are for a standard unit with rectangular air spigot and no filter installed.
2. Airflows are for dry coil. Reduce airflow by 10% in high moisture removal conditions.
3. In a free blow application, beware of exceeding indoor fan motor's full load amp limit.
4. Refer to page 70 for filter pressure drop.

Dimensions

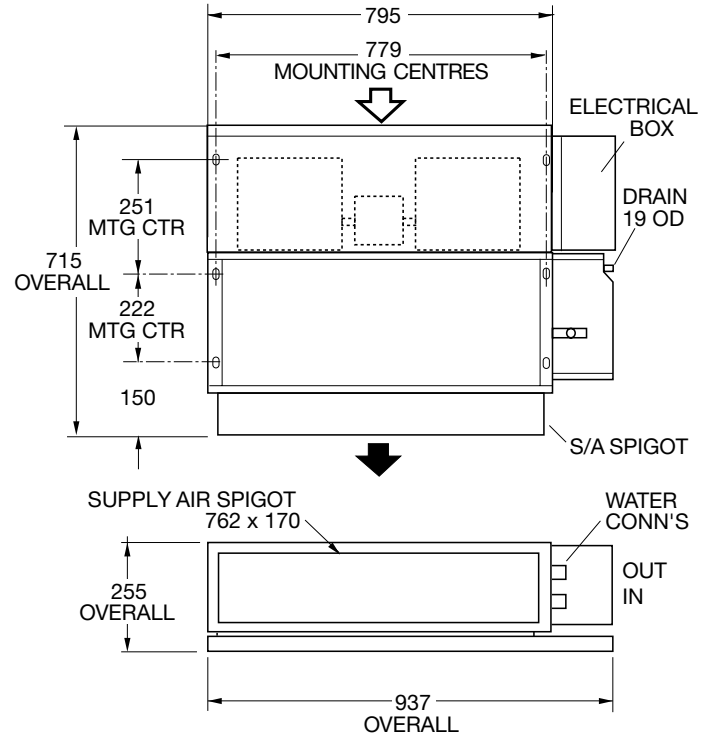

Sound Levels

Supply Air Outlet

Fan Speed	Sound Pressure Levels (SPL) (dB)						
	dB(A)	Octave Band Centre Frequency (Hz)					
		125	250	500	1K	2K	4K
Low	43	50	48	42	31	25	16
Med	44	51	49	43	33	28	19
High	47	55	52	45	37	31	24

Return Air Inlet + Case Breakout

Fan Speed	Sound Pressure Levels (SPL) (dB)						
	dB(A)	Octave Band Centre Frequency (Hz)					
		125	250	500	1K	2K	4K
Low	47	51	49	46	42	37	29
Med	50	52	52	49	45	41	33
High	53	55	54	52	48	44	37

Sound levels are specified as in-situ conditions. For more information and adjustment factors for your specific installation please find supplementary booklets under the relevant units on our website www.temperzone.com

IMDL 90H-4

				Low Air flow			Medium Air flow			Nominal Air flow		
4 row chilled water coil				290 L/s			350 L/s			480 L/s		
Air on DB/WB	W. flow L/s	P.D. kPa	Cooling kW	Entering water temp			Entering water temp			Entering water temp		
				6	7	8	6	7	8	6	7	8
23/17	0.3	8.2	total	6.5	6.0	5.5	7.2	6.7	6.0	8.4	7.7	7.4
			sensible	4.6	4.3	4.1	5.2	5.0	4.7	6.4	6.1	6.0
	0.45	16.7	total	7.1	6.5	5.9	8.0	7.3	6.7	9.5	8.8	8.0
			sensible	4.8	4.6	4.3	5.5	5.2	5.0	6.9	6.6	6.2
	0.6	28.5	total	7.5	6.9	6.3	8.5	7.8	7.1	10.4	9.5	8.7
			sensible	5.0	4.7	4.4	5.8	5.4	5.1	7.2	6.9	6.5
27/19	0.3	8.2	total	8.0	7.4	6.9	8.8	8.2	7.6	10.2	9.5	8.8
			sensible	5.6	5.4	5.2	6.4	6.1	5.9	7.9	7.6	7.3
	0.45	16.7	total	8.7	8.1	7.5	9.8	9.1	8.5	11.7	10.9	10.1
			sensible	5.9	5.7	5.4	6.8	6.5	6.3	8.5	8.2	7.8
	0.6	28.5	total	9.1	8.5	7.9	10.4	9.7	9.0	12.7	11.8	10.9
			sensible	6.1	5.9	5.6	7.1	6.8	6.5	8.9	8.5	8.2

IMDL 90H-3/1

3 row chilled water coil				290 L/s			350 L/s			480 L/s		
Air on DB/WB	W. flow L/s	P.D. kPa	Cooling kW	Entering water temp			Entering water temp			Entering water temp		
				6	7	8	6	7	8	6	7	8
23/17	0.25	9.9	total	5.6	5.1	4.7	6.1	5.6	5.1	7.0	6.4	5.9
			sensible	4.0	3.8	3.6	4.5	4.3	4.1	5.5	5.3	5.1
	0.35	18.1	total	6.1	5.6	5.1	6.8	6.3	5.6	7.9	7.3	6.6
			sensible	4.2	4.0	3.8	4.8	4.6	4.3	5.9	5.6	5.4
	0.45	28.1	total	6.5	5.9	5.4	7.3	6.7	6.0	8.6	7.9	7.2
			sensible	4.4	4.2	3.9	5.0	4.8	4.5	6.2	5.9	5.6
27/19	0.25	9.9	total	6.8	6.4	5.9	7.5	7.0	6.4	8.5	7.9	7.3
			sensible	4.9	4.8	4.6	5.6	5.4	5.2	6.8	6.6	6.4
	0.35	18.1	total	7.5	7.0	6.5	8.3	7.8	7.2	9.7	9.0	8.4
			sensible	5.2	5.0	4.8	5.9	5.7	5.5	7.3	7.0	6.8
	0.45	28.5	total	8.0	7.4	6.9	8.9	8.3	7.7	10.6	9.8	9.1
			sensible	5.4	5.2	5.0	6.2	5.9	5.7	7.6	7.3	7.0

1 row hot water coil

Air on DB	W. flow L/s	P.D. kPa	Heating kW	Entering water temp			Entering water temp			Entering water temp		
				50	65	80	50	65	80	50	65	80
15	0.1	10.3	heat	5.2	7.5	9.8	5.8	8.2	10.7	6.6	9.4	12.3
	0.14	18.8	heat	5.6	8.0	10.5	6.2	8.8	11.5	7.3	10.4	13.5
	0.18	29.4	heat	5.9	8.4	11.0	6.5	9.3	12.2	7.8	11.1	14.4
21	0.1	10.3	heat	4.4	6.6	8.9	4.8	7.3	9.7	5.5	8.3	11.2
	0.14	18.8	heat	4.7	7.1	9.5	5.1	7.8	10.4	6.0	9.2	12.3
	0.18	29.4	heat	4.9	7.4	10.0	5.4	8.2	11.0	6.4	9.7	13.1

Performance Data

IMDL 90H

Air Handling

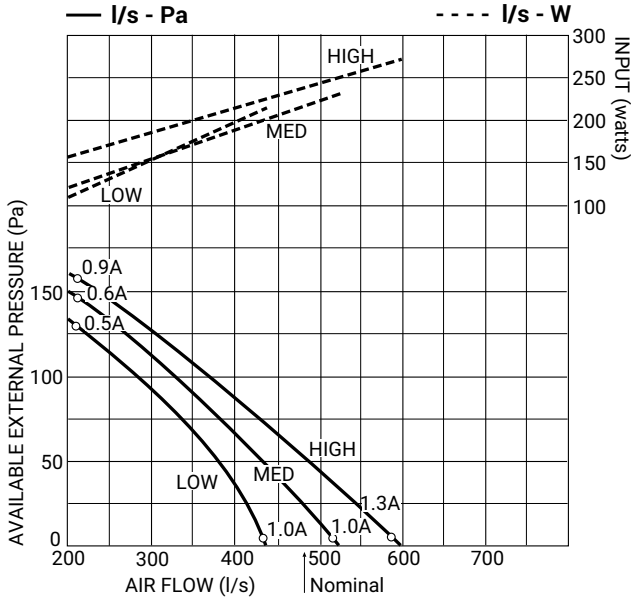

Note:

1. Airflows given are for a standard unit with rectangular air spigot and no filter installed.
2. Airflows are for dry coil. Reduce airflow by 10% in high moisture removal conditions.
3. In a free blow application, beware of exceeding indoor fan motor's full load amp limit.
4. Refer to page 70 for filter pressure drop.

Dimensions

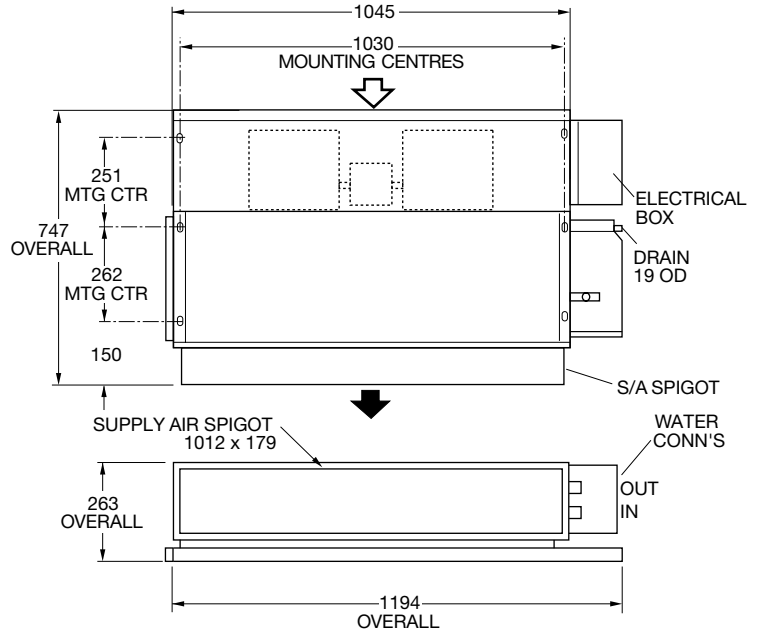

Sound Levels

Supply Air Outlet

Fan Speed	Sound Pressure Levels (SPL) (dB)						
	dB(A)	Octave Band Centre Frequency (Hz)					
		125	250	500	1K	2K	4K
Low	44	53	48	42	35	30	22
Med	47	55	51	44	38	32	26
High	49	57	53	47	41	35	30

Return Air Inlet + Case Breakout

Fan Speed	Sound Pressure Levels (SPL) (dB)						
	dB(A)	Octave Band Centre Frequency (Hz)					
		125	250	500	1K	2K	4K
Low	52	58	54	50	46	44	37
Med	55	60	56	53	49	46	40
High	56	58	56	55	50	47	43

Sound levels are specified as in-situ conditions. For more information and adjustment factors for your specific installation please find supplementary booklets under the relevant units on our website www.temperzone.com

IMDL 130H-4

				Low Air flow			Medium Air flow			Nominal Air flow		
4 row chilled water coil				400 L/s			525 L/s			650 L/s		
Air on DB/WB	W. flow L/s	P.D. kPa	Cooling kW	Entering water temp			Entering water temp			Entering water temp		
				6	7	8	6	7	8	6	7	8
23/17	0.3	10.5	total	8.5	7.9	7.2	9.7	8.9	8.2	10.6	9.7	8.9
			sensible	6.1	5.8	5.5	7.3	7.0	6.7	8.3	8.0	7.6
	0.45	21.8	total	9.5	8.7	7.9	11.1	10.2	9.3	12.4	11.3	10.3
			sensible	6.5	6.1	5.8	7.9	7.5	7.1	9.1	8.6	8.2
	0.6	36.7	total	10.1	9.3	8.4	12.0	11.0	10.0	13.5	12.4	11.3
			sensible	6.8	6.4	6.0	8.3	7.8	7.4	9.6	9.1	8.6
27/19	0.3	10.5	total	10.5	9.8	9.1	11.9	11.0	10.3	12.9	12.0	11.1
			sensible	7.5	7.2	6.9	9.0	8.7	8.4	10.4	10.0	9.7
	0.45	21.8	total	11.7	10.9	10.1	13.6	12.7	11.8	15.2	14.1	13.1
			sensible	8.0	7.7	7.4	9.8	9.4	9.0	11.3	10.9	10.4
	0.6	36.7	total	12.4	11.6	10.7	14.7	13.7	12.7	16.6	15.5	14.3
			sensible	8.4	8.0	7.7	10.2	9.8	9.4	11.9	11.4	10.9

IMDL 130H-3/1

3 row chilled water coil				400 L/s			525 L/s			650 L/s		
Air on DB/WB	W. flow L/s	P.D. kPa	Cooling kW	Entering water temp			Entering water temp			Entering water temp		
				6	7	8	6	7	8	6	7	8
23/17	0.2	8.5	total	6.7	6.2	5.6	7.4	6.8	6.2	7.9	7.2	6.7
			sensible	5.1	4.9	4.7	6.0	5.8	5.6	6.9	6.6	6.4
	0.3	17.6	total	7.7	7.1	6.4	8.7	8.0	7.3	9.5	8.8	8.0
			sensible	5.5	5.3	5.0	6.6	6.3	6.0	7.5	7.2	6.9
	0.4	29.5	total	8.4	7.7	7.0	9.7	8.9	8.1	10.7	9.9	9.0
			sensible	5.8	5.5	5.2	7.0	6.7	6.3	8.0	7.7	7.3
27/19	0.2	8.5	total	8.2	7.7	7.1	9.1	8.4	7.8	9.6	9.0	8.3
			sensible	6.3	6.1	5.9	7.5	7.2	7.0	8.5	8.3	8.1
	0.3	17.6	total	9.5	8.8	8.2	10.7	10.0	9.2	11.6	10.9	10.0
			sensible	6.8	6.6	6.3	8.2	7.9	7.6	9.3	9.0	8.7
	0.4	29.5	total	10.3	9.6	8.9	11.9	11.1	10.3	13.2	12.2	11.3
			sensible	7.2	6.9	6.6	8.6	8.3	8.0	9.9	9.5	9.2

1 row hot water coil

Air on DB	W. flow L/s	P.D. kPa	Heating kW	Entering water temp			Entering water temp			Entering water temp		
				50	65	80	50	65	80	50	65	80
15	0.08	9.0	heat	6.4	9.2	11.9	7.1	10.1	13.1	7.6	10.8	14.1
	0.12	18.4	heat	7.2	10.3	13.3	8.2	11.7	15.2	8.9	12.7	16.5
	0.16	30.0	heat	7.7	11.0	14.3	8.9	12.7	16.5	9.6	14.0	18.2
21	0.08	9.0	heat	5.3	8.0	10.8	5.8	8.9	11.9	6.3	9.5	12.7
	0.12	18.4	heat	5.9	9.0	12.1	6.8	10.2	13.7	7.4	11.2	15.0
	0.16	30.8	heat	6.4	9.6	13.0	7.3	11.2	15.0	8.1	13.3	16.5

Performance Data

IMDL 130H

Air Handling

Dimensions

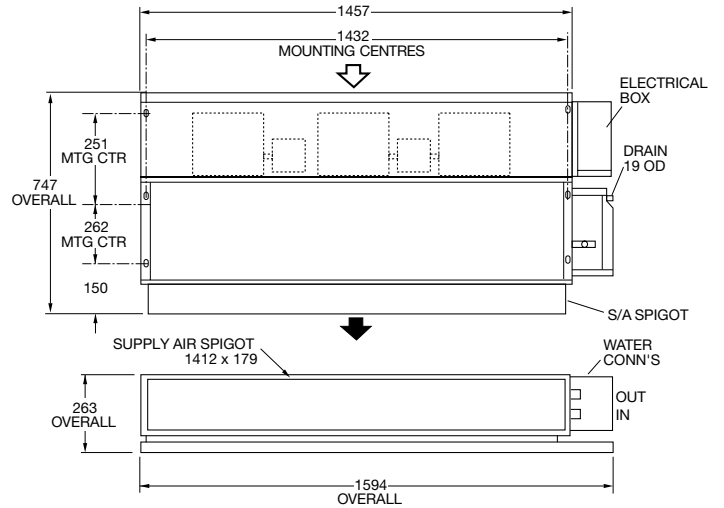
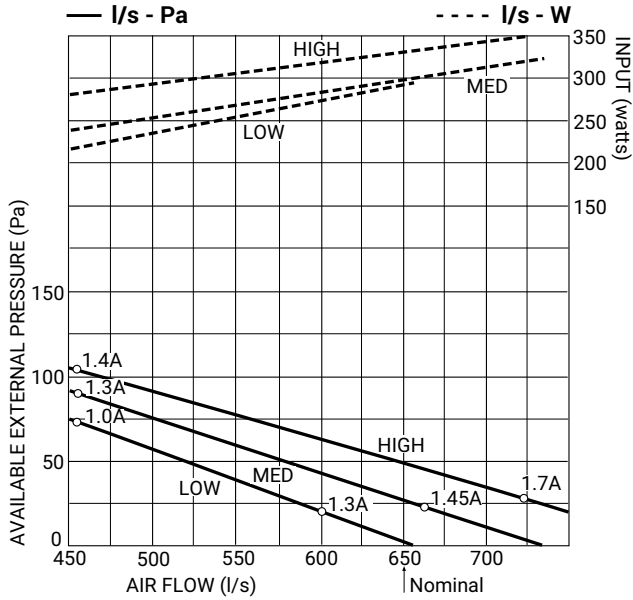

Note:

1. Airflows given are for a standard unit with rectangular air spigot and no filter installed.
2. Airflows are for dry coil. Reduce airflow by 10% in high moisture removal conditions.
3. In a free blow application, beware of exceeding indoor fan motor's full load amp limit.
4. Refer to page 70 for filter pressure drop.

Sound Levels

Supply Air Outlet

Fan Speed	Sound Pressure Levels (SPL) (dB)						
	dB(A)	Octave Band Centre Frequency (Hz)					
		125	250	500	1K	2K	4K
Low	46	55	50	44	37	31	23
Med	48	55	52	46	40	34	26
High	50	57	55	48	42	37	30

Return Air Inlet + Case Breakout

dB(A)	Sound Pressure Levels (SPL) (dB)					
	125	250	500	1K	2K	4K
51	55	54	50	43	39	33
53	57	55	52	47	41	36
55	59	58	54	48	44	39

Sound levels are specified as in-situ conditions. For more information and adjustment factors for your specific installation please find supplementary booklets under the relevant units on our website www.temperzone.com

Premium Range (Low Profile)

IMDL-Y

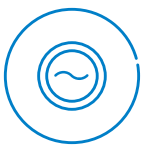

High Efficiency EC Motor



Easy Clean Plastic Drain



Opposite Hand

Premium Range (IMDL-Y) Specifications



Model	IMDL 40Y	IMDL 60Y	IMDL 90Y	IMDL 130Y
Nominal Air Flow (l/s) *	200	330	400	650
Fan Type	Forward curved centrifugal double inlet double width			
No. of Fan Scrolls	1	2	2	3
Motor Type	Electronically Commutated (EC) DC Direct drive			
Power Source **	1 Phase 230 Volt AC 50 Hz			
No. of Motors	1	1	1	2
Motor Rating (W)	182	243	243	182 + 243
Full Load Amps (A)***	1.4	1.8	1.8	1.4 + 1.8 (3.2)
Electric Heating (kW)	1.5	2.0	3.0	4.0
Electric Heat Current (A)	6.6	8.8	13.2	17.6
Heat Exchanger Type	Aluminium corrugated plate fins to expanded rifled copper tube			
Cooling/Heating Medium	Chilled Water or Hot Water			
Finish	Zinc galvanised steel			
Test Pressure	2100 kPa			
Connection Sizes Cooling Coil (mm)	Ø 20 (¾" BSP)	Ø 20 (¾" BSP)	Ø 25 (1" BSP)	Ø 25 (1" BSP)
Connection Sizes Heating Coil (mm)	Ø 15 (1/2" BSP)			
Air Filter Type	Washable G2 / EU2 (Supplied Standard)			
No. of Air Filters	1	1	1	2
Air Filter Size (mm)	545 x 234 x 13	795 x 234 x 13	1045 x 243 x 13	725 x 243 x 13
Weight Incl. Water (kg)	25	34	46	67
Nett Dry Weight (kg)	24	32	42	62
Shipping Weight (kg)	25	34	45	65

* with no filters fitted and with a dry coil surface

** Voltage fluctuation limits 200-252V

*** Fan only, excluding Electric Heating

Cooling and Heating Coil options:

4 Row Cooling only

3 Row Cooling + 1 Row Heating

4 Row Cooling plus Electric Heating

IMDL 40Y-4

				Low Air flow			Medium Air flow			Nominal Air flow		
4 row chilled water coil				100 L/s			150 L/s			200 L/s		
Air on DB/WB	W. flow L/s	P.D. kPa	Cooling kW	Entering water temp			Entering water temp			Entering water temp		
				6	7	8	6	7	8	6	7	8
23/17	0.15	6.7	total	2.6	2.4	2.2	3.6	3.3	3.0	3.9	3.6	3.3
			sensible	1.6	1.5	1.4	2.3	2.2	2.1	2.6	2.5	2.4
	0.25	16.7	total	2.9	2.6	2.4	4.1	3.8	3.5	4.6	4.2	3.9
			sensible	1.7	1.6	1.5	2.6	2.4	2.3	2.9	2.7	2.6
	0.35	30.5	total	3.0	2.7	2.5	4.4	4.1	3.7	4.9	4.6	4.2
			sensible	1.8	1.7	1.6	2.7	2.5	2.4	3.0	2.9	2.7
27/19	0.15	6.7	total	3.3	3.1	2.9	4.1	3.8	3.5	4.7	4.4	4.1
			sensible	2.0	1.9	1.8	2.6	2.5	2.4	3.2	3.1	2.9
	0.25	16.7	total	3.5	3.3	3.1	4.6	4.3	4.0	5.6	5.2	4.8
			sensible	2.1	2.0	1.9	2.9	2.7	2.6	3.5	3.4	3.2
	0.35	30.5	total	3.6	3.4	3.2	4.9	4.5	4.2	6.0	5.6	5.2
			sensible	2.2	2.1	2.0	3.0	2.8	2.7	3.7	3.5	3.4

IMDL 40Y-3/1

3 row chilled water coil				100 L/s			150 L/s			200 L/s		
Air on DB/WB	W. flow L/s	P.D. kPa	Cooling kW	Entering water temp			Entering water temp			Entering water temp		
				6	7	8	6	7	8	6	7	8
23/17	0.1	5.4	total	2.1	2.0	1.8	2.5	2.3	2.1	2.8	2.5	2.3
			sensible	1.4	1.4	1.3	1.8	1.7	1.6	2.1	2.0	1.9
	0.2	18.78	total	2.5	2.3	2.1	3.1	2.9	2.6	3.6	3.3	3.0
			sensible	1.6	1.5	1.4	2.0	1.9	1.8	2.5	2.3	2.2
	0.25	27.9	total	2.6	2.4	2.1	3.3	3.0	2.7	3.8	3.5	3.2
			sensible	1.6	1.5	1.4	2.1	2.0	1.9	2.5	2.4	2.3
27/19	0.1	5.4	total	2.6	2.4	2.2	3.0	2.8	2.6	3.4	3.1	2.9
			sensible	1.8	1.7	1.6	2.2	2.1	2.0	2.7	2.6	2.5
	0.2	18.8	total	3.1	2.8	2.6	3.7	3.5	3.2	4.4	4.1	3.8
			sensible	2.0	1.9	1.8	2.5	2.4	2.3	3.1	2.9	2.8
	0.25	27.9	total	3.1	2.9	2.7	4.0	3.8	3.5	4.7	4.3	4.0
			sensible	2.0	1.9	1.8	2.6	2.5	2.4	3.1	3.0	2.9

1 row hot water coil

Air on DB	W. flow L/s	P.D. kPa	Heating kW	Entering water temp			Entering water temp			Entering water temp		
				50	65	80	50	65	80	50	65	80
15	0.04	6.4	heat	1.8	2.6	3.4	2.1	3.0	3.9	2.3	3.4	4.4
	0.07	17.4	heat	2.0	2.9	3.8	2.4	3.5	4.5	2.7	3.9	5.0
	0.1	33	heat	2.1	3.1	4.0	2.6	3.7	4.8	2.9	4.1	5.4
21	0.04	6.4	heat	1.5	2.3	3.0	1.8	2.6	3.5	2.0	3.0	4.0
	0.07	17.4	heat	1.7	2.6	3.4	2.0	3.0	4.0	2.3	3.5	4.6
	0.1	33	heat	1.8	2.7	3.7	2.1	3.2	4.3	2.4	3.7	5.0

Performance Data

IMDL 40Y

Air Handling

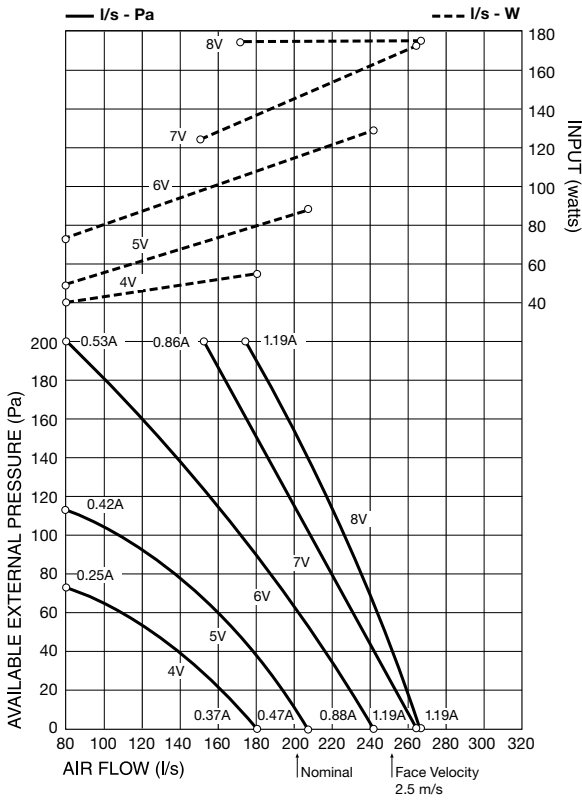

Note: Airflows are for dry coil. Reduce airflow by 10% in high moisture removal conditions. **Air flows given are for IMDL-Y units without filter installed.** Refer to page 70 for filter pressure drop.

Dimensions

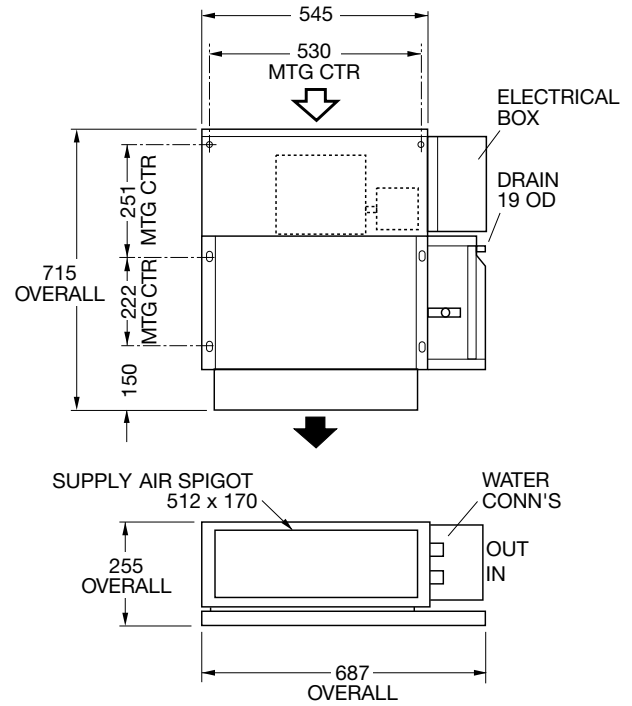

Sound Levels

Return Air Inlet + Case Breakout							
Vdc	Sound Pressure Levels (SPL) (dB)						
	dB(A)	Octave Band Centre Frequency (Hz)					
		125	250	500	1K	2K	4K
8	56	56	58	54	50	48	47
7	56	56	58	54	49	47	46
6	53	53	55	51	47	44	42
5	49	50	51	47	44	40	38
4	46	48	48	44	41	36	33
3	40	46	42	39	35	29	25
2	35	41	38	33	28	24	21

Supply Air Outlet							
Vdc	Sound Pressure Levels (SPL) (dB)						
	dB(A)	Octave Band Centre Frequency (Hz)					
		125	250	500	1K	2K	4K
8	50	61	55	45	37	35	29
7	48	59	54	44	37	34	28
6	46	57	51	41	35	31	24
5	42	53	47	37	32	27	20
4	39	49	45	34	28	23	16
3	34	45	40	29	22	15	7
2	33	46	38	24	14	7	0

Sound levels are specified as in-situ conditions. For more information and adjustment factors for your specific installation please find supplementary booklets under the relevant units on our website www.temperzone.com

IMDL 60Y-4

				Low Air flow			Medium Air flow			Nominal Air flow		
4 row chilled water coil				250 L/s			300 L/s			330 L/s		
Air on DB/WB	W. flow L/s	P.D. kPa	Cooling kW	Entering water temp			Entering water temp			Entering water temp		
				6	7	8	6	7	8	6	7	8
23/17	0.15	8.5	total	4.9	4.5	4.1	5.2	4.8	4.4	5.4	5.0	4.6
			sensible	3.3	3.1	3.0	3.6	3.5	3.3	3.9	3.7	3.5
	0.22	17.1	total	5.6	5.2	4.7	6.1	5.6	5.1	6.4	5.9	5.4
			sensible	3.6	3.4	3.2	4.0	3.8	3.6	4.2	4.0	3.8
	0.3	29.4	total	6.1	5.6	5.1	6.7	6.2	5.7	7.1	6.6	6.0
			sensible	3.8	3.6	3.4	4.2	4.0	3.8	4.5	4.3	4.1
27/19	0.15	8.5	total	6.0	5.6	5.2	6.4	6.0	5.6	6.6	6.2	5.7
			sensible	4.1	3.9	3.8	4.5	4.4	4.2	4.8	4.6	4.4
	0.22	17.1	total	6.9	6.4	6.0	7.5	7.0	6.5	7.8	7.3	6.8
			sensible	4.4	4.2	4.1	4.9	4.8	4.6	5.2	5.0	4.8
	0.3	29.4	total	7.5	7.0	6.5	8.3	7.7	7.2	8.7	8.1	7.5
			sensible	4.7	4.5	4.3	5.2	5.0	4.8	5.6	5.3	5.1

IMDL 60Y-3/1

3 row chilled water coil				250 L/s			300 L/s			330 L/s		
Air on DB/WB	W. flow L/s	P.D. kPa	Cooling kW	Entering water temp			Entering water temp			Entering water temp		
				6	7	8	6	7	8	6	7	8
23/17	0.11	8.2	total	3.7	3.4	3.1	3.9	3.6	3.2	4.0	3.7	3.3
			sensible	2.8	2.7	2.6	3.1	3.0	2.9	3.3	3.2	3.1
	0.17	18.1	total	4.5	4.0	3.7	4.8	4.4	4.0	5.0	4.6	4.1
			sensible	3.1	3.0	2.8	3.4	3.3	3.1	3.7	3.5	3.3
	0.23	30.6	total	4.9	4.5	4.1	5.3	4.9	4.4	5.6	5.1	4.6
			sensible	3.3	3.1	3.0	3.7	3.5	3.3	3.9	3.7	3.5
27/19	0.11	8.2	total	4.5	4.2	3.9	4.7	4.4	4.0	4.8	4.5	4.1
			sensible	3.5	3.4	3.3	3.9	3.8	3.6	4.1	4.0	3.9
	0.17	18.1	total	5.4	5.0	4.6	5.8	5.4	5.0	6.0	5.5	5.1
			sensible	3.9	3.7	3.6	4.3	4.1	4.0	4.5	4.4	4.2
	0.23	30.6	total	6.0	5.5	5.1	6.5	6.0	5.5	6.7	6.3	5.8
			sensible	4.1	3.9	3.8	4.5	4.4	4.2	4.8	4.6	4.4

1 row hot water coil

Air on DB	W. flow L/s	P.D. kPa	Heating kW	Entering water temp			Entering water temp			Entering water temp		
				50	65	80	50	65	80	50	65	80
15	0.04	8.1	heat	3.0	4.3	5.5	3.2	4.6	6.0	3.3	4.7	6.2
	0.06	16.8	heat	3.4	4.9	6.4	3.6	5.2	6.8	3.8	5.4	7.0
	0.08	28.1	heat	3.7	5.3	6.9	3.9	5.7	7.3	4.1	5.8	7.6
21	0.04	8.1	heat	2.5	3.8	5.1	2.7	4.1	5.4	2.8	4.2	5.7
	0.06	16.8	heat	2.8	4.3	5.8	3.0	4.6	6.2	3.2	4.8	6.4
	0.08	28.1	heat	3.1	4.6	6.2	3.3	5.0	6.7	3.4	5.2	6.9

Performance Data

IMDL 60Y

Air Handling

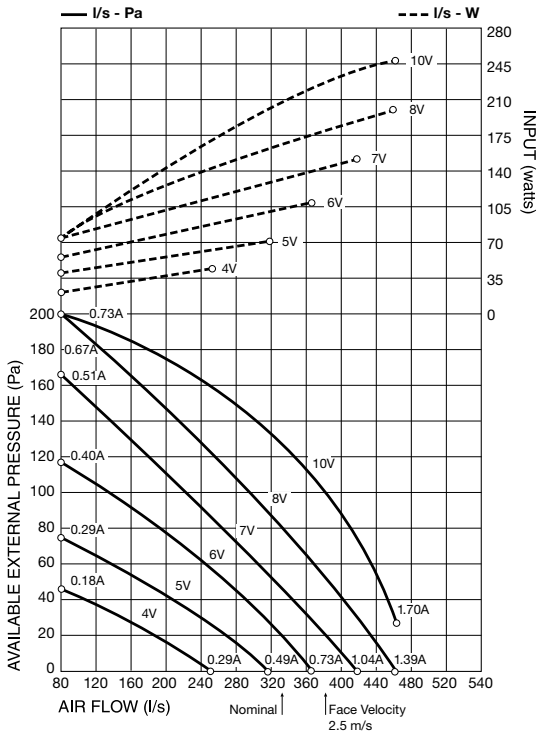

Note: Airflows are for dry coil. Reduce airflow by 10% in high moisture removal conditions. **Air flows given are for IMDL-Y units without filter installed.** Refer to page 70 for filter pressure drop.

Dimensions

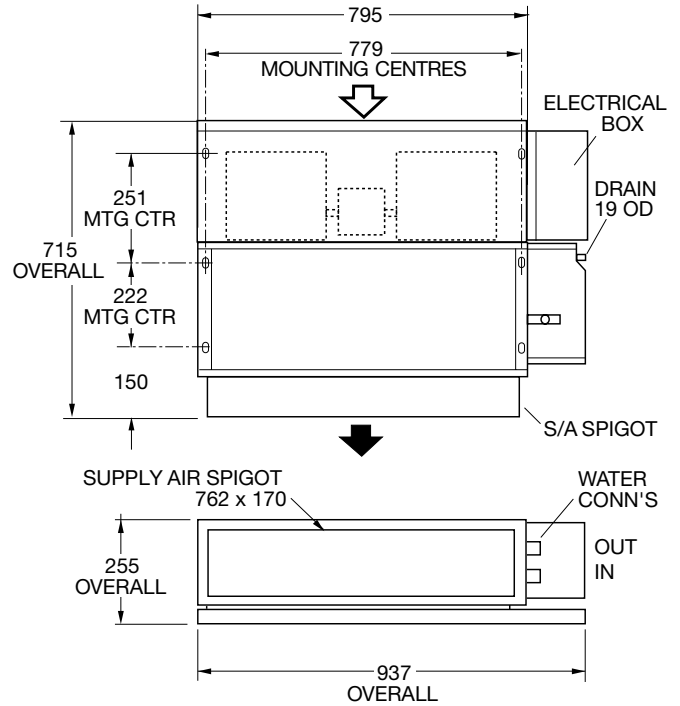

Sound Levels

Return Air Inlet + Case Breakout							
Vdc	Sound Pressure Levels (SPL) (dB)						
	dB(A)	Octave Band Centre Frequency (Hz)					
		125	250	500	1K	2K	4K
10	57	58	59	55	52	48	44
8	57	56	58	55	51	48	43
7	55	54	56	53	49	46	41
6	53	52	54	51	47	43	38
5	50	48	52	48	44	40	34
4	46	46	48	45	40	36	29
3	42	42	44	42	35	32	25
2	35	44	40	32	26	24	18

Supply Air Outlet							
Vdc	Sound Pressure Levels (SPL) (dB)						
	dB(A)	Octave Band Centre Frequency (Hz)					
		125	250	500	1K	2K	4K
10	50	59	55	48	40	35	30
8	47	57	52	45	37	32	27
7	46	56	51	43	35	30	24
6	43	52	48	40	33	26	20
5	39	50	44	37	28	22	15
4	37	47	42	34	24	18	10
3	33	43	40	29	17	10	5
2	33	46	39	25	11	7	4

Sound levels are specified as in-situ conditions. For more information and adjustment factors for your specific installation please find supplementary booklets under the relevant units on our website www.temperzone.com

IMDL 90Y-4

				Low Air flow			Medium Air flow			Nominal Air flow		
4 row chilled water coil				200 L/s			300 L/s			400 L/s		
Air on DB/WB	W. flow L/s	P.D. kPa	Cooling kW	Entering water temp			Entering water temp			Entering water temp		
				6	7	8	6	7	8	6	7	8
23/17	0.3	8.2	total	5.2	4.8	4.4	6.6	6.1	5.5	7.7	7.1	6.4
			sensible	3.5	3.3	3.1	4.7	4.4	4.2	5.7	5.4	5.1
	0.45	16.7	total	5.5	5.1	4.6	7.3	6.7	6.1	8.6	7.9	7.2
			sensible	3.6	3.4	3.2	4.9	4.7	4.1	6.1	5.8	5.5
	0.6	28.5	total	5.6	5.2	4.7	7.6	7.0	6.4	9.2	8.5	7.7
			sensible	3.7	3.5	3.3	5.1	4.8	4.5	6.3	6.0	5.7
27/19	0.3	8.2	total	6.4	6.0	5.5	8.2	7.6	7.1	9.4	8.8	8.1
			sensible	4.3	4.1	3.9	5.8	5.5	5.3	7.0	6.7	6.5
	0.45	16.7	total	6.7	6.3	5.8	8.9	8.3	7.7	10.6	9.9	9.2
			sensible	4.5	4.3	4.0	6.1	5.8	5.6	7.5	7.2	6.9
	0.6	28.5	total	6.9	6.5	6.0	9.4	8.8	8.1	11.3	10.6	9.8
			sensible	4.6	4.4	4.1	6.3	6.0	5.7	7.8	7.5	7.2

IMDL 90Y-3/1

3 row chilled water coil				290 L/s			350 L/s			480 L/s		
Air on DB/WB	W. flow L/s	P.D. kPa	Cooling kW	Entering water temp			Entering water temp			Entering water temp		
				6	7	8	6	7	8	6	7	8
23/17	0.25	9.9	total	4.6	4.2	3.8	5.7	5.2	4.7	6.5	5.9	5.4
			sensible	3.1	3.0	2.8	4.1	3.9	3.7	4.9	4.7	4.5
	0.35	18.1	total	4.9	4.5	4.1	6.2	5.7	5.2	7.2	6.7	6.0
			sensible	3.2	3.1	2.9	4.3	4.1	3.9	5.2	5.0	4.7
	0.45	28.1	total	5.1	4.7	4.3	6.6	6.1	5.5	7.8	7.2	6.5
			sensible	3.3	3.2	3.0	4.5	4.3	4.0	5.5	5.2	4.9
27/19	0.25	9.9	total	5.6	5.3	4.9	7.0	6.5	6.0	7.9	7.4	6.8
			sensible	3.9	3.7	3.5	5.1	4.9	4.7	6.1	5.9	5.7
	0.35	18.1	total	6.0	5.6	5.2	7.7	7.1	6.6	8.9	8.3	7.7
			sensible	4.0	3.9	3.6	5.4	5.1	4.9	6.5	6.2	6.0
	0.45	28.5	total	6.2	5.8	5.4	8.1	7.6	7.0	9.6	8.9	8.3
			sensible	4.1	4.0	3.8	5.5	5.3	5.1	6.8	6.5	6.2

1 row hot water coil

Air on DB	W. flow L/s	P.D. kPa	Heating kW	Entering water temp			Entering water temp			Entering water temp		
				50	65	80	50	65	80	50	65	80
15	0.1	10.3	heat	4.4	6.2	8.1	5.3	7.6	9.9	6.1	8.7	11.4
	0.14	18.8	heat	4.6	6.5	8.6	5.7	8.2	10.7	6.7	9.6	12.5
	0.18	29.4	heat	4.8	6.8	8.8	6.0	8.6	11.2	7.0	10.0	13.0
21	0.1	10.3	heat	3.6	5.4	7.3	4.4	6.7	9.0	5.0	7.7	10.3
	0.14	18.8	heat	3.8	5.7	7.7	4.7	7.2	9.6	5.5	8.4	11.2
	0.18	29.4	heat	3.9	5.9	8.0	5.0	7.5	10.1	5.8	8.8	11.8

Performance Data

IMDL 90Y

Air Handling

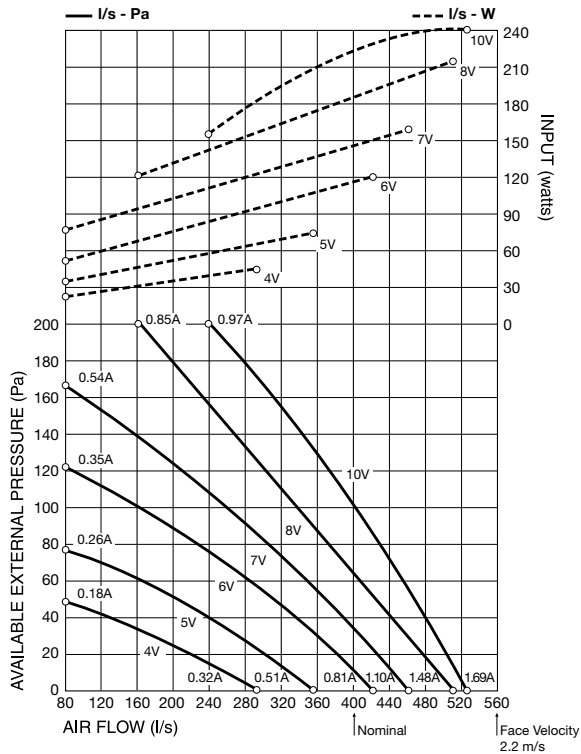

Note: Airflows are for dry coil. Reduce airflow by 10% in high moisture removal conditions. **Air flows given are for IMDL-Y units without filter installed.** Refer to page 70 for filter pressure drop.

Dimensions

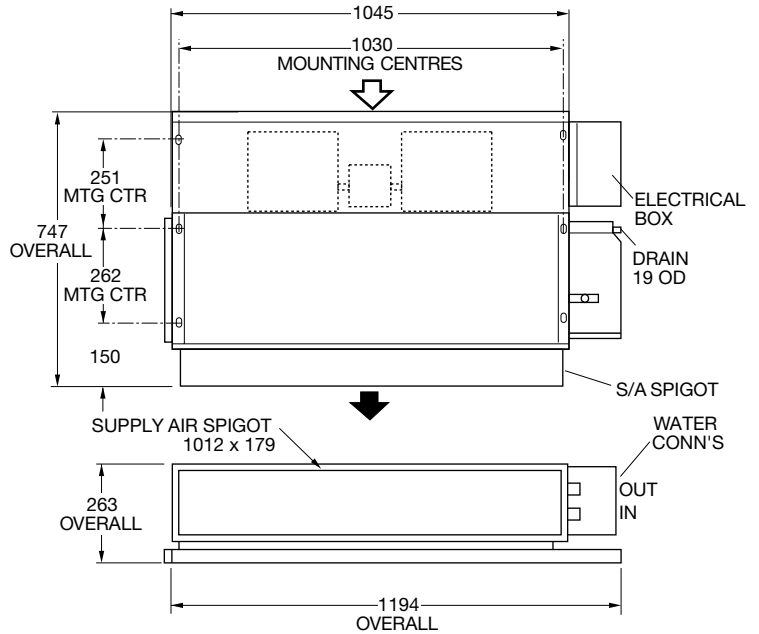

Sound Levels

Return Air Inlet + Case Breakout

Vdc	Sound Pressure Levels (SPL) (dB)						
	dB(A)	Octave Band Centre Frequency (Hz)					
		125	250	500	1K	2K	4K
10	58	60	60	55	51	49	45
8	56	58	59	53	50	47	42
7	53	56	56	51	47	44	40
6	51	54	54	48	44	41	36
5	47	49	49	45	40	37	31
4	43	46	46	42	35	32	24
3	39	43	43	37	31	28	20
2	35	43	39	32	26	22	15

Supply Air Outlet

Vdc	Sound Pressure Levels (SPL) (dB)						
	dB(A)	Octave Band Centre Frequency (Hz)					
		125	250	500	1K	2K	4K
10	51	60	55	49	43	37	33
8	49	59	53	46	41	34	30
7	47	57	51	43	38	32	27
6	44	54	48	41	34	29	24
5	41	51	45	38	32	25	19
4	37	47	40	35	26	21	12
3	33	42	40	28	19	13	4
2	31	45	35	24	15	9	2

Sound levels are specified as in-situ conditions. For more information and adjustment factors for your specific installation please find supplementary booklets under the relevant units on our website www.temperzone.com

IMDL 130Y-4

				Low Air flow			Medium Air flow			Nominal Air flow		
4 row chilled water coil				400 L/s			525 L/s			650 L/s		
Air on DB/WB	W. flow L/s	P.D. kPa	Cooling kW	Entering water temp			Entering water temp			Entering water temp		
				6	7	8	6	7	8	6	7	8
23/17	0.3	10.5	total	8.5	7.9	7.2	9.7	8.9	8.2	10.6	9.7	8.9
			sensible	6.1	5.8	5.5	7.3	7.0	6.7	8.3	8.0	7.6
	0.45	21.8	total	9.5	8.7	7.9	11.1	10.2	9.3	12.4	11.3	10.3
			sensible	6.5	6.1	5.8	7.9	7.5	7.1	9.1	8.6	8.2
	0.6	36.7	total	10.1	9.3	8.4	12.0	11.0	10.0	13.5	12.4	11.3
			sensible	6.8	6.4	6.0	8.3	7.8	7.4	9.6	9.1	8.6
27/19	0.3	10.5	total	10.5	9.8	9.1	11.9	11.0	10.3	12.9	12.0	11.1
			sensible	7.5	7.2	6.9	9.0	8.7	8.4	10.4	10.0	9.7
	0.45	21.8	total	11.7	10.9	10.1	13.6	12.7	11.8	15.2	14.1	13.1
			sensible	8.0	7.7	7.4	9.8	9.4	9.0	11.3	10.9	10.4
	0.6	36.7	total	12.4	11.6	10.7	14.7	13.7	12.7	16.6	15.5	14.3
			sensible	8.4	8.0	7.7	10.2	9.8	9.4	11.9	11.4	10.9

IMDL 130Y-3/1

3 row chilled water coil				400 L/s			525 L/s			650 L/s		
Air on DB/WB	W. flow L/s	P.D. kPa	Cooling kW	Entering water temp			Entering water temp			Entering water temp		
				6	7	8	6	7	8	6	7	8
23/17	0.2	8.5	total	6.7	6.2	5.6	7.4	6.8	6.2	7.9	7.2	6.7
			sensible	5.1	4.9	4.7	6.0	5.8	5.6	6.9	6.6	6.4
	0.3	17.6	total	7.7	7.1	6.4	8.7	8.0	7.3	9.5	8.8	8.0
			sensible	5.5	5.3	5.0	6.6	6.3	6.0	7.5	7.2	6.9
	0.4	29.5	total	8.4	7.7	7.0	9.7	8.9	8.1	10.7	9.9	9.0
			sensible	5.8	5.5	5.2	7.0	6.7	6.3	8.0	7.7	7.3
27/19	0.2	8.5	total	8.2	7.7	7.1	9.1	8.4	7.8	9.6	9.0	8.3
			sensible	6.3	6.1	5.9	7.5	7.2	7.0	8.5	8.3	8.1
	0.3	17.6	total	9.5	8.8	8.2	10.7	10.0	9.2	11.6	10.9	10.0
			sensible	6.8	6.6	6.3	8.2	7.9	7.6	9.3	9.0	8.7
	0.4	29.5	total	10.3	9.6	8.9	11.9	11.1	10.3	13.2	12.2	11.3
			sensible	7.2	6.9	6.6	8.6	8.3	8.0	9.9	9.5	9.2

1 row hot water coil

Air on DB	W. flow L/s	P.D. kPa	Heating kW	Entering water temp			Entering water temp			Entering water temp		
				50	65	80	50	65	80	50	65	80
15	0.08	9.0	heat	6.4	9.2	11.9	7.1	10.1	13.1	7.6	10.8	14.1
	0.12	18.4	heat	7.2	10.3	13.3	8.2	11.7	15.2	8.9	12.7	16.5
	0.16	30.0	heat	7.7	11.0	14.3	8.9	12.7	16.5	9.6	14.0	18.2
21	0.08	9.0	heat	5.3	8.0	10.8	5.8	8.9	11.9	6.3	9.5	12.7
	0.12	18.4	heat	5.9	9.0	12.1	6.8	10.2	13.7	7.4	11.2	15.0
	0.16	30.8	heat	6.4	9.6	13.0	7.3	11.2	15.0	8.1	13.3	16.5

Performance Data

IMDL 130Y

Air Handling

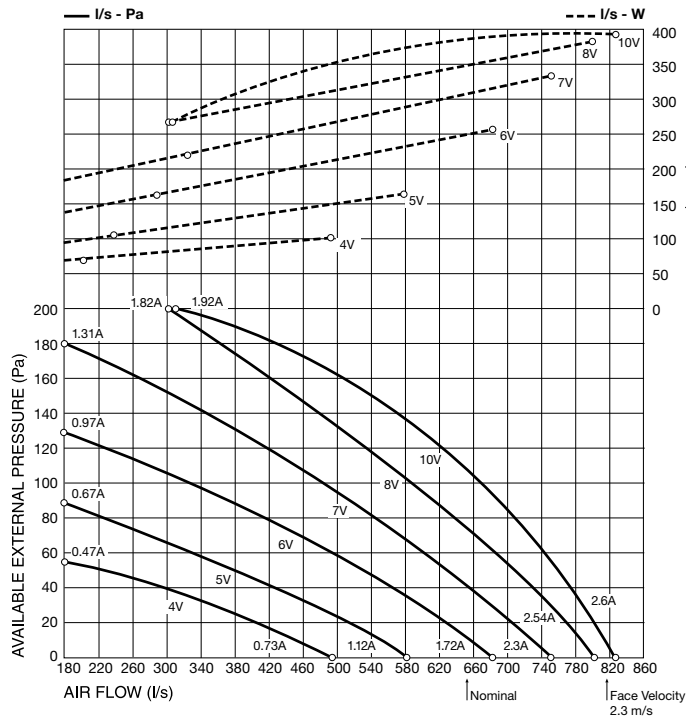

Note: Airflows are for dry coil. Reduce airflow by 10% in high moisture removal conditions. **Air flows given are for IMDL-Y units without filter installed.** Refer to page 70 for filter pressure drop.

Dimensions

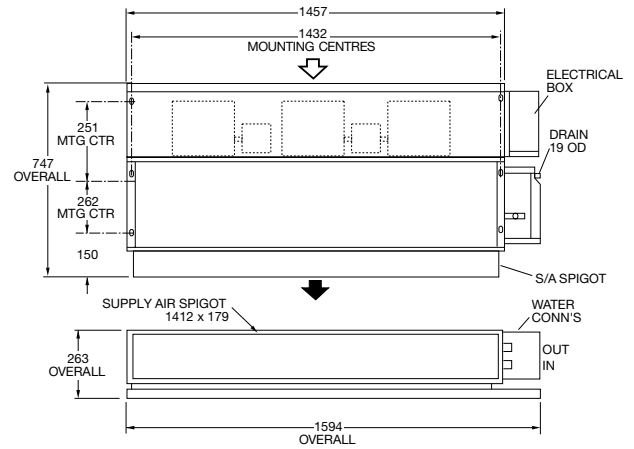

Sound Levels

Return Air Inlet + Case Breakout

Vdc	Sound Pressure Levels (SPL) (dB)						
	dB(A)	Octave Band Centre Frequency (Hz)					
		125	250	500	1K	2K	4K
10	62	62	64	60	56	54	52
8	61	61	63	59	54	52	51
7	61	61	63	58	54	52	51
6	57	58	60	54	51	49	48
5	55	55	57	52	49	46	45
4	51	51	54	49	45	42	40
3	46	47	48	44	40	36	33
2	40	45	44	37	32	28	23

Supply Air Outlet

Vdc	Sound Pressure Levels (SPL) (dB)						
	dB(A)	Octave Band Centre Frequency (Hz)					
		125	250	500	1K	2K	4K
10	56	63	61	53	49	46	40
8	56	63	59	53	48	45	39
7	55	62	59	52	47	45	39
6	52	59	56	48	45	42	36
5	49	56	53	46	42	39	32
4	46	53	50	42	38	35	28
3	42	53	46	36	32	29	20
2	36	46	42	32	25	20	12

Sound levels are specified as in-situ conditions. For more information and adjustment factors for your specific installation please find supplementary booklets under the relevant units on our website www.temperzone.com

Premium Range (Multizone)

IXDL



Multiple EC Motor



Multiple Zone Supply
Spigot

Premium Range (IXDL) Specifications

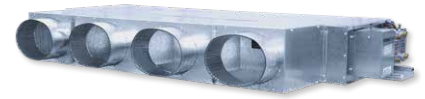

Model	IXDL 40Y	IXDL 90Y	IXDL 130Y	IXDL 160Y	IXDL 200Y
Nominal Air Flow (l/s) @ 100 Pa external static *	200	400	600	800	1000
Air Flow Range (l/s)	0-225	0-450	0-675	0-900	0-1125
No of Outlet Spigots	1	2	3	4	5
Control	0-10Vdc (High/Med/Low optional with conversion boards added)				
Fan Type	Forward curved Centrifugal double inlet double width				
No. of Fans	1	2	3	4	5
Motor Type	Electronically Commutated (EC) DC Direct drive				
Power Source **	1 Phase 230 Volt AC 50 Hz				
No. of Motors	1	2	3	4	5
Motor Rating (W)	182	182 (x2)	182 (x3)	182 (x4)	182 (x5)
Full Load Amps (A)	1.4	1.4 x 2 (2.8)	1.4 x 3 (4.2)	1.4 x 4 (5.6)	1.4 x 5 (7.0)
Amps at Nominal Air Flow (A)	0.4	0.4 x 2 (0.8)	0.4 x 3 (1.2)	0.4 x 4 (1.6)	0.4 x 5 (2.0)
Heat Exchanger Type	Epoxy Coated aluminium corrugated plate fins to expanded rifled copper tubing				
Cooling/Heating Medium	Chilled Water or Hot Water				
Finish	Natural zinc galvanised steel				
Test Pressure	2100 kPa				
Connection Sizes Cooling Coil (mm)	Ø 25 (1" BSP)				
Connection Sizes Heating Coil (mm)	Ø 13 (1/2" BSP)				
Air Filter Type	Washable G2 / EU2				
No. of Air Filters	1	2	2	2	2
Air Filter Size (mm)	466 x 161 x 13	484 x 161 x 13	984 x 161 x 13	858 x 161 x 13	1058 x 161 x 13
Outlet Spigot Options (mm)	250 Ø				
Weight Incl. Water (kg)	34	53	73	92	112
Nett Dry Weight (kg)	32	49	68	84	103
Shipping Weight (kg)	34	53	72	90	110

* with no filters fitted and with a dry coil surface.

** Voltage fluctuation limits 200-252V

Cooling and Heating Coil options:

3 Row or 4 Row Cooling only

3 Row or 4 row Cooling + 1 Row Heating

IXDL 40-4-Y

				Low Speed			Medium Speed			High Speed		
4 row chilled water coil				100 L/s			150 L/s			200 L/s		
Air on DB/WB	W. flow L/s	P.D. kPa	Cooling kW	Entering water temp			Entering water temp			Entering water temp		
				6	7	8	6	7	8	6	7	8
23/17	0.2	2.0	total	2.3	2.2	2.0	2.9	2.7	2.4	3.4	3.1	2.8
			sensible	1.6	1.5	1.4	2.1	2.0	1.9	2.6	2.5	2.4
	0.4	7.3	total	2.6	2.4	2.2	3.4	3.1	2.8	4.0	3.7	3.4
			sensible	1.7	1.6	1.5	2.3	2.2	2.1	2.9	2.7	2.6
	0.6	14.6	total	2.7	2.5	2.3	3.6	3.3	3.0	4.4	4.0	3.7
			sensible	1.8	1.7	1.6	2.4	2.3	2.2	3.0	2.9	2.7
27/19	0.2	2.0	total	2.9	2.7	2.5	3.6	3.3	3.1	4.1	3.9	3.6
			sensible	2.0	1.9	1.8	2.6	2.5	2.5	3.2	3.1	3.0
	0.4	7.3	total	3.2	3.0	2.8	4.2	3.9	3.6	5.0	4.6	4.3
			sensible	2.1	2.0	1.9	2.9	2.7	2.6	3.6	3.4	3.3
	0.6	14.6	total	3.3	3.1	2.9	4.5	4.2	3.9	5.4	5.0	4.7
			sensible	2.2	2.1	2.0	3.0	2.9	2.8	3.8	3.6	3.5

IXDL 40-3/1-Y

3 row chilled water coil				100 L/s			150 L/s			200 L/s		
Air on DB/WB	W. flow L/s	P.D. kPa	Cooling kW	Entering water temp			Entering water temp			Entering water temp		
				6	7	8	6	7	8	6	7	8
23/17	0.2	3.4	total	2.1	1.9	1.8	2.6	2.4	2.2	3.0	2.7	2.5
			sensible	1.5	1.4	1.3	1.9	1.8	1.7	2.3	2.2	2.1
	0.4	11.6	total	2.4	2.2	2.0	3.0	2.8	2.6	3.7	3.3	3.0
			sensible	1.6	1.5	1.4	2.1	2.0	1.9	2.6	2.5	2.3
	0.6	24.2	total	2.5	2.3	2.1	3.3	3.0	2.8	4.0	3.7	3.3
			sensible	1.6	1.5	1.4	2.2	2.1	2.0	2.7	2.6	2.4
27/19	0.2	3.4	total	2.6	2.4	2.2	3.2	3.0	2.7	3.7	3.4	3.1
			sensible	1.8	1.7	1.6	2.4	2.3	2.2	2.9	2.8	2.7
	0.4	11.6	total	2.9	2.7	2.5	3.8	3.5	3.3	4.5	4.2	3.9
			sensible	1.9	1.8	1.7	2.6	2.5	2.4	3.2	3.1	2.9
	0.6	24.2	total	3.1	2.9	2.7	4.1	3.8	3.5	4.9	4.6	4.3
			sensible	2.0	1.9	1.8	2.7	2.6	2.5	3.4	3.2	3.1

1 row hot water coil

Air on DB	W. flow L/s	P.D. kPa	Heating kW	Entering water temp			Entering water temp			Entering water temp		
				50	65	80	50	65	80	50	65	80
15	0.06	2.0	heat	1.9	2.8	3.6	2.4	3.5	4.5	2.7	3.9	5.1
	0.12	6.9	heat	2.1	3.0	3.9	2.7	3.8	5.0	3.1	4.5	5.8
	0.18	14.3	heat	2.2	3.2	4.1	2.8	4.1	5.3	3.4	4.8	6.2
21	0.06	2.0	heat	1.6	2.4	3.3	2.0	3.0	4.1	2.3	3.4	4.6
	0.12	6.9	heat	1.7	2.6	3.6	2.2	3.3	4.5	2.6	3.9	5.2
	0.18	14.3	heat	1.8	2.8	3.8	2.3	3.5	4.7	2.8	4.2	5.6

Performance Data

IXDL 40Y

Air Handling

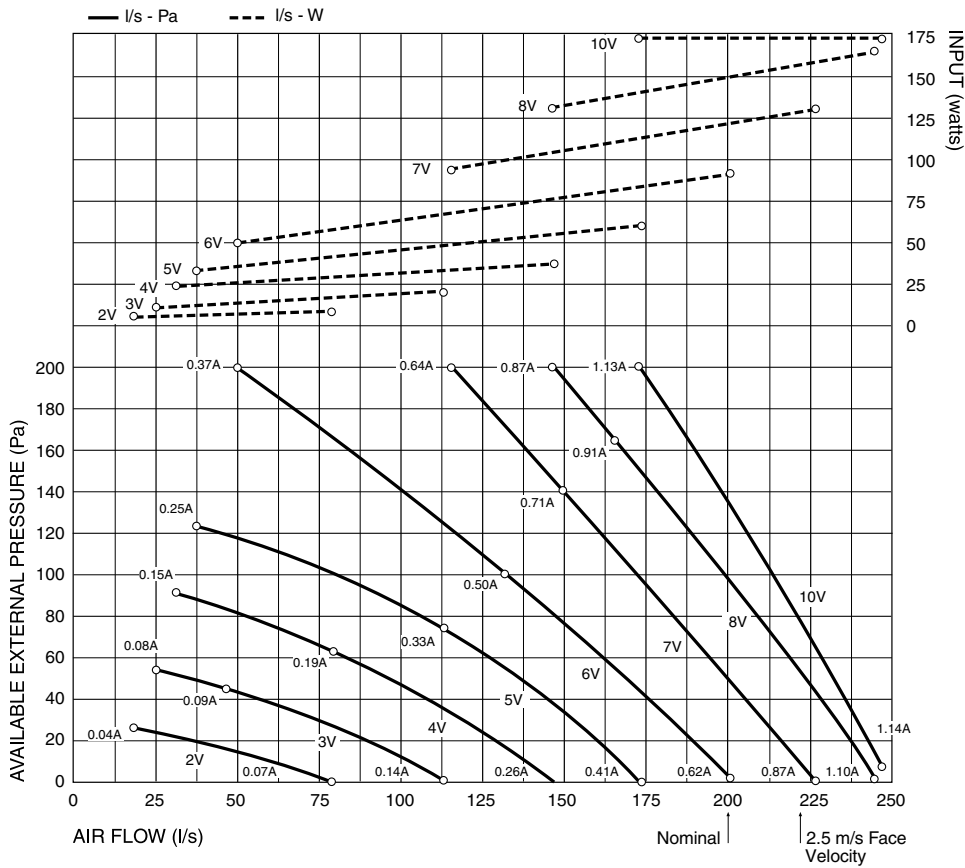

Note: Airflows are for dry coil. Reduce airflow by 10% in high moisture removal conditions.

Air flows given are for IXDL-Y units without filter installed. Refer to page 70 for filter pressure drop.

Sound Levels

Return Air Inlet + Case Breakout

Vdc	Sound Pressure Levels (SPL) (dB)						
	dB(A)	Octave Band Centre Frequency (Hz)					
		125	250	500	1K	2K	4K
9	57	64	61	55	47	46	42
8	57	64	61	55	46	46	42
7	55	63	59	53	45	43	40
6	53	61	58	51	43	41	37
5	50	58	54	48	41	37	34
4	47	55	52	44	37	32	28
3	43	52	47	40	33	27	22
2	36	48	39	34	25	20	16

Supply Air Outlet

Vdc	Sound Pressure Levels (SPL) (dB)						
	dB(A)	Octave Band Centre Frequency (Hz)					
		125	250	500	1K	2K	4K
9	52	65	57	43	35	32	29
8	52	65	57	43	35	32	32
7	50	63	55	41	33	29	27
6	48	61	54	39	32	27	25
5	45	58	51	37	29	23	21
4	42	55	47	30	25	18	15
3	38	52	43	28	21	12	9
2	34	49	36	23	14	6	2

Sound levels are specified as in-situ conditions. For more information and adjustment factors for your specific installation please find supplementary booklets under the relevant units on our website www.temperzone.com

IXDL 90-4-Y

				Low Speed			Medium Speed			High Speed		
4 row chilled water coil				200 L/s			300 L/s			400 L/s		
Air on DB/WB	W. flow L/s	P.D. kPa	Cooling kW	Entering water temp			Entering water temp			Entering water temp		
				6	7	8	6	7	8	6	7	8
23/17	0.2	3.0	total	4.4	4.0	3.7	5.3	4.9	4.5	6.0	5.5	5.0
			sensible	3.1	2.9	2.8	4.0	3.9	3.7	4.9	4.7	4.5
	0.4	10.7	total	5.0	4.6	4.2	6.5	6.0	5.4	7.6	7.0	6.4
			sensible	3.4	3.2	3.0	4.6	4.3	4.1	5.5	5.3	5.0
	0.6	22.6	total	5.3	4.9	4.5	7.1	6.5	5.9	8.5	7.8	7.1
			sensible	3.5	3.3	3.1	4.8	4.6	4.3	5.9	5.6	5.3
27/19	0.2	3.0	total	5.4	5.0	4.7	6.5	6.1	5.6	7.3	6.8	6.3
			sensible	3.8	3.7	3.5	5.1	4.9	4.7	6.1	5.9	5.7
	0.4	10.7	total	6.2	5.8	5.3	8.0	7.4	6.9	9.3	8.7	8.0
			sensible	4.2	4.0	3.8	5.6	5.4	5.2	6.9	6.6	6.3
	0.6	22.6	total	6.5	6.1	5.7	8.7	8.1	7.5	10.4	9.7	8.9
			sensible	4.3	4.1	4.0	6.0	5.7	5.5	7.3	7.1	6.7

IXDL 90-3/1-Y

3 row chilled water coil				200 L/s			300 L/s			400 L/s		
Air on DB/WB	W. flow L/s	P.D. kPa	Cooling kW	Entering water temp			Entering water temp			Entering water temp		
				6	7	8	6	7	8	6	7	8
23/17	0.2	5.1	total	3.9	3.6	3.3	4.7	4.4	4.0	5.3	4.9	4.4
			sensible	2.8	2.7	2.5	3.6	3.5	3.3	4.3	4.2	4.0
	0.4	17.6	total	4.6	4.2	3.8	5.9	5.4	4.9	6.8	6.3	5.7
			sensible	3.1	2.9	2.8	4.1	3.9	3.7	5.0	4.7	4.5
	0.6	36.7	total	4.9	4.5	4.1	6.4	5.9	5.3	7.7	7.0	6.4
			sensible	3.2	3.1	2.9	4.4	4.1	3.9	5.3	5.0	4.8
27/19	0.2	5.1	total	4.9	4.5	4.2	5.8	5.4	5.0	6.5	6.0	5.6
			sensible	3.5	3.4	3.2	4.5	4.4	4.2	5.4	5.2	5.1
	0.4	17.6	total	5.7	5.3	4.9	7.2	6.7	6.2	8.4	7.8	7.2
			sensible	3.8	3.7	3.5	5.1	4.9	4.7	6.1	5.9	5.7
	0.6	36.7	total	6.1	5.7	5.2	7.9	7.4	6.8	9.4	8.8	8.1
			sensible	4.0	3.8	3.6	5.4	5.1	4.9	6.6	6.3	6.0

1 row hot water coil

Air on DB	W. flow L/s	P.D. kPa	Heating kW	Entering water temp			Entering water temp			Entering water temp		
				50	65	80	50	65	80	50	65	80
15	0.06	3.1	heat	3.5	5.1	6.6	4.2	6.1	7.9	4.7	6.7	8.7
	0.12	10.6	heat	4.1	5.8	7.5	5.1	7.2	9.4	5.8	8.3	10.8
	0.18	21.9	heat	4.3	6.2	8.1	5.4	7.7	10.1	6.4	9.1	11.9
21	0.06	3.1	heat	2.9	4.4	6.0	3.5	5.3	7.1	3.9	5.9	8.0
	0.12	10.6	heat	3.3	5.1	6.8	4.1	6.3	8.5	4.8	7.3	9.7
	0.18	21.9	heat	3.5	5.4	7.2	4.4	6.8	9.1	5.3	8.0	10.7

Performance Data

IXDL 90Y

Air Handling

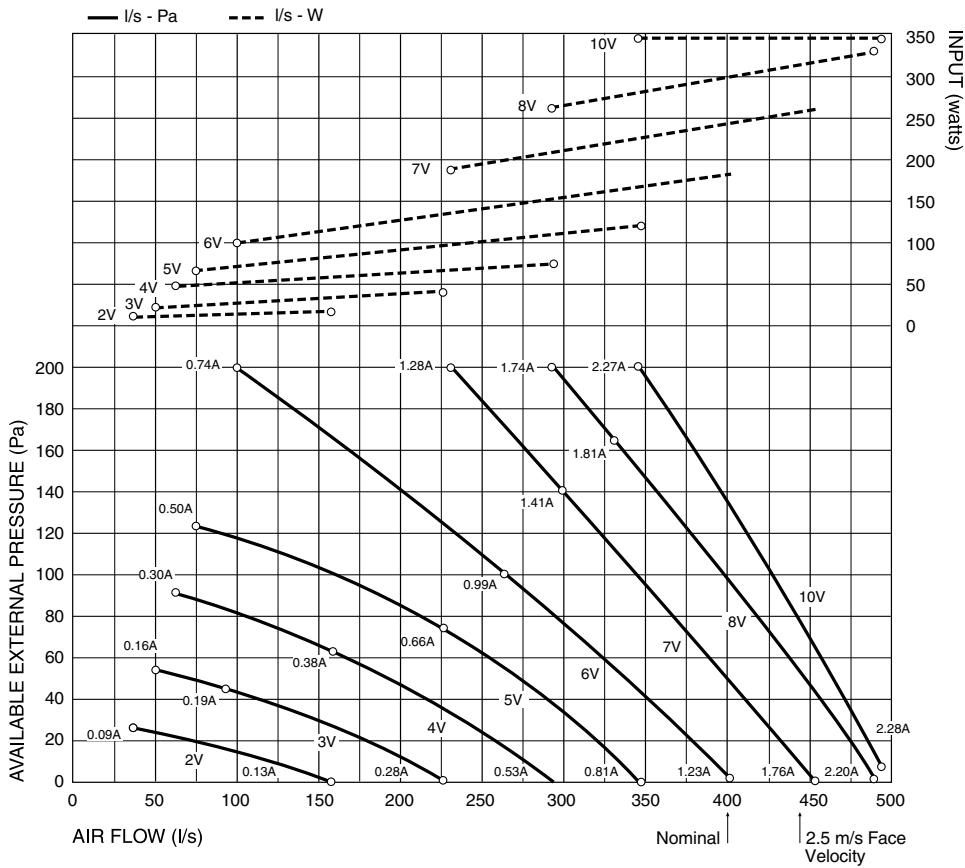

Note: Airflows are for dry coil. Reduce airflow by 10% in high moisture removal conditions.

Air flows given are for IXDL-Y units without filter installed. Refer to page 70 for filter pressure drop.

For **individual fan performance** see page 60 - IXDL 40Y Fan Curve

Sound Levels

Return Air Inlet + Case Breakout							
Vdc	Sound Pressure Levels (SPL) (dB)						
	dB(A)	Octave Band Centre Frequency (Hz)					
		125	250	500	1K	2K	4K
9	58	65	62	56	47	46	43
8	58	65	62	56	47	47	43
7	56	63	60	54	45	44	40
6	53	60	58	51	43	41	37
5	50	58	54	48	40	37	33
4	47	55	52	44	37	32	28
3	42	50	47	39	31	26	21
2	35	47	38	32	24	19	15

Supply Air Outlet							
Vdc	Sound Pressure Levels (SPL) (dB)						
	dB(A)	Octave Band Centre Frequency (Hz)					
		125	250	500	1K	2K	4K
9	53	65	59	47	40	38	36
8	53	65	58	46	40	38	36
7	51	63	56	44	38	36	33
6	49	61	55	41	36	32	30
5	46	57	51	38	33	28	26
4	42	55	47	34	29	23	20
3	38	50	43	30	24	17	13
2	33	47	35	24	16	11	6

Sound levels are specified as in-situ conditions. For more information and adjustment factors for your specific installation please find supplementary booklets under the relevant units on our website www.temperzone.com

IXDL 130-4-Y

				Low Speed			Medium Speed			High Speed		
4 row chilled water coil				300 L/s			450 L/s			600 L/s		
Air on DB/WB	W. flow L/s	P.D. kPa	Cooling kW	Entering water temp			Entering water temp			Entering water temp		
				6	7	8	6	7	8	6	7	8
23/17	0.2	3.9	total	6.0	5.5	5.1	7.1	6.5	5.9	7.7	7.1	6.5
			sensible	4.4	4.2	4.0	5.7	5.5	5.2	6.8	6.5	6.3
	0.4	13.5	total	7.2	6.6	6.0	9.1	8.3	7.6	10.4	9.5	8.7
			sensible	4.9	4.6	4.4	6.5	6.2	5.9	7.9	7.5	7.2
	0.6	28	total	7.7	7.1	6.5	10.1	9.2	8.4	11.9	10.9	9.9
			sensible	5.2	4.8	4.6	7.0	6.6	6.2	8.5	8.1	7.7
27/19	0.2	3.9	total	7.4	6.9	6.4	8.6	8.0	7.4	9.4	8.8	8.1
			sensible	5.4	5.2	5.0	7.1	6.8	6.6	8.5	8.3	8.0
	0.4	13.5	total	8.8	8.3	7.7	11.1	10.3	9.6	12.7	11.8	11.0
			sensible	6.1	5.8	5.6	8.1	7.8	7.5	9.8	9.4	9.1
	0.6	28	total	9.5	8.9	8.2	12.4	11.6	10.7	14.6	13.6	12.6
			sensible	6.4	6.1	5.8	8.6	8.3	7.9	10.5	10.1	9.7

IXDL 130-3/1-Y

3 row chilled water coil				300 L/s			450 L/s			600 L/s		
Air on DB/WB	W. flow L/s	P.D. kPa	Cooling kW	Entering water temp			Entering water temp			Entering water temp		
				6	7	8	6	7	8	6	7	8
23/17	0.2	6.6	total	5.4	4.9	4.5	6.3	5.8	5.3	6.9	6.3	5.8
			sensible	4.0	3.8	3.6	5.1	4.9	4.7	6.1	5.8	5.6
	0.35	17.8	total	6.3	5.8	5.3	7.8	7.2	6.5	8.9	8.2	7.4
			sensible	4.4	4.2	3.9	5.7	5.5	5.2	6.8	6.5	6.3
	0.5	33.7	total	6.8	6.3	5.7	8.7	8.0	7.3	10.1	9.3	8.5
			sensible	4.6	4.4	4.1	6.1	5.8	5.5	7.4	7.0	6.7
27/19	0.2	6.6	total	6.6	6.2	5.7	7.7	7.2	6.6	8.4	7.9	7.3
			sensible	5.0	4.8	4.6	6.4	6.2	6.0	7.6	7.4	7.2
	0.35	17.8	total	7.8	7.3	6.7	9.6	8.9	8.3	10.9	10.1	9.4
			sensible	5.4	5.2	5.0	7.1	6.8	6.6	8.5	8.2	7.9
	0.5	33.7	total	8.4	7.9	7.3	10.7	10.0	9.2	12.4	11.6	10.8
			sensible	5.7	5.5	5.2	7.5	7.3	6.9	9.1	8.8	8.4

1 row hot water coil

Air on DB	W. flow L/s	P.D. kPa	Heating kW	Entering water temp			Entering water temp			Entering water temp		
				50	65	80	50	65	80	50	65	80
15	0.06	4.0	heat	4.8	6.8	8.8	5.5	7.8	10.2	5.9	8.5	11.1
	0.12	13.6	heat	5.7	8.1	10.5	6.9	9.9	12.9	7.8	11.2	14.5
	0.18	28.0	heat	6.1	8.7	11.4	7.7	11.0	14.2	8.8	12.6	16.4
21	0.06	4.0	heat	3.9	6.0	8.0	4.5	6.9	9.2	4.9	7.5	10.0
	0.12	13.6	heat	4.7	7.1	9.5	5.7	8.7	11.6	6.5	9.8	13.2
	0.18	28.0	heat	5.0	7.7	10.3	6.3	9.6	12.9	7.3	11.1	14.8

Performance Data

IXDL 130Y

Air Handling

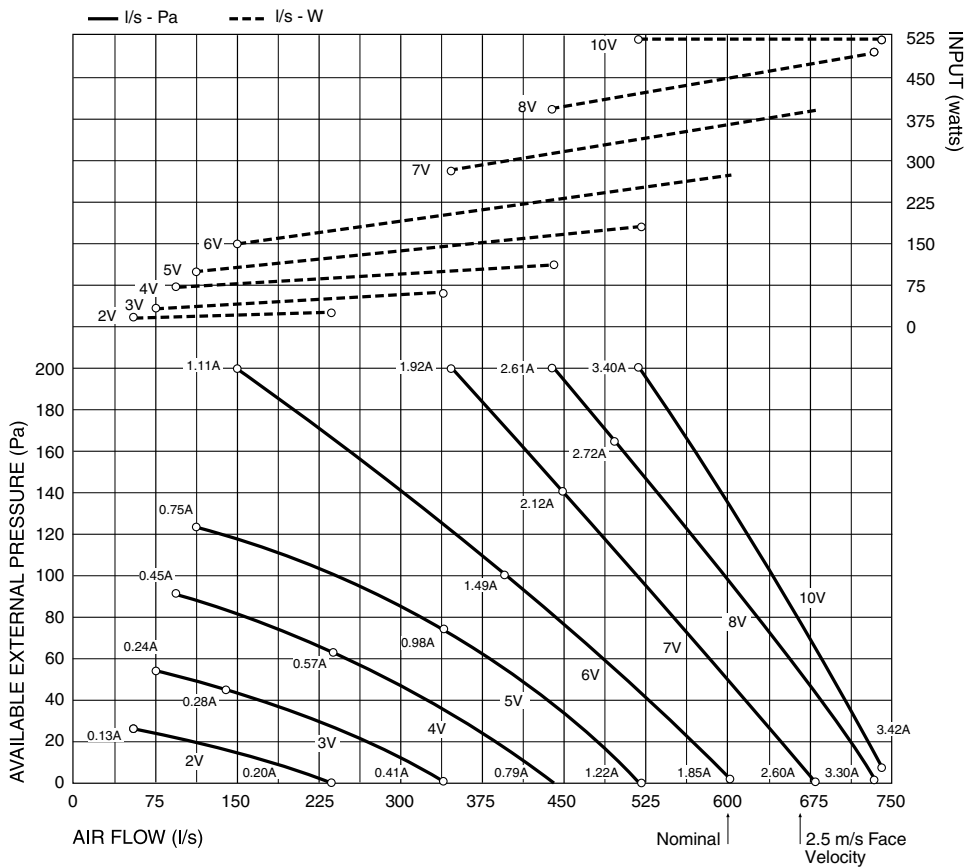

Note: Airflows are for dry coil. Reduce airflow by 10% in high moisture removal conditions.

Air flows given are for IXDL-Y units without filter installed. Refer to page 70 for filter pressure drop.

For **individual fan performance** see page 60 - IXDL 40Y Fan Curve

Sound Levels

Return Air Inlet + Case Breakout

Vdc	Sound Pressure Levels (SPL) (dB)						
	dB(A)	Octave Band Centre Frequency (Hz)					
		125	250	500	1K	2K	4K
9	64	71	69	63	54	53	49
8	64	71	69	62	53	52	48
7	62	69	67	60	52	49	45
6	59	67	65	57	49	46	41
5	56	63	61	53	46	43	37
4	52	60	57	50	42	36	31
3	45	53	51	43	36	28	23
2	39	47	43	37	29	26	19

Supply Air Outlet

Vdc	Sound Pressure Levels (SPL) (dB)						
	dB(A)	Octave Band Centre Frequency (Hz)					
		125	250	500	1K	2K	4K
9	61	73	66	54	47	45	42
8	61	73	65	53	46	44	41
7	58	70	64	51	44	42	38
6	56	68	61	48	42	39	35
5	53	65	58	44	39	34	30
4	49	61	55	41	35	29	25
3	44	57	48	35	29	23	17
2	36	49	41	29	20	14	8

Sound levels are specified as in-situ conditions. For more information and adjustment factors for your specific installation please find supplementary booklets under the relevant units on our website www.temperzone.com

IXDL 160-4-Y

				Low Speed			Medium Speed			High Speed		
4 row chilled water coil				400 L/s			600 L/s			800 L/s		
Air on DB/WB	W. flow L/s	P.D. kPa	Cooling kW	Entering water temp			Entering water temp			Entering water temp		
				6	7	8	6	7	8	6	7	8
23/17	0.25	6.9	total	7.9	7.3	6.6	9.3	8.5	7.8	10.1	9.3	8.4
			sensible	5.8	5.5	5.2	7.5	7.2	6.9	8.9	8.6	8.3
	0.45	19.8	total	9.4	8.6	7.8	11.6	10.7	9.7	13.3	12.2	11.1
			sensible	6.5	6.1	5.8	8.5	8.1	7.7	10.2	9.8	9.3
	0.65	38.3	total	10.1	9.3	8.4	13.0	12.0	10.9	15.2	14.0	12.7
			sensible	6.8	6.4	6.0	9.1	8.6	8.2	11.0	10.5	10.0
27/19	0.25	6.9	total	9.7	9.1	8.4	11.3	10.6	9.8	12.3	11.5	10.7
			sensible	7.2	6.9	6.7	9.3	9.1	8.8	11.2	10.9	10.6
	0.45	19.8	total	11.5	10.7	10.0	14.3	13.3	12.3	16.2	15.2	14.0
			sensible	8.0	7.6	7.3	10.5	10.1	9.7	12.7	12.3	11.8
	0.65	38.3	total	12.4	11.5	10.7	16.0	14.9	13.8	18.7	17.4	16.2
			sensible	8.3	8.0	7.6	11.3	10.8	10.3	13.7	13.2	12.7

IXDL 160-3/1-Y

3 row chilled water coil				400 L/s			600 L/s			800 L/s		
Air on DB/WB	W. flow L/s	P.D. kPa	Cooling kW	Entering water temp			Entering water temp			Entering water temp		
				6	7	8	6	7	8	6	7	8
23/17	0.25	11.6	total	7.1	6.5	5.9	8.3	7.6	7.0	9.1	8.4	7.7
			sensible	5.3	5.0	4.8	6.7	6.5	6.2	8.0	7.7	7.4
	0.35	21.0	total	7.9	7.3	6.6	9.6	8.7	8.0	10.8	9.9	9.0
			sensible	5.6	5.3	5.0	7.3	6.9	6.6	8.6	8.3	8.0
	0.45	33.0	total	8.5	7.8	7.1	10.5	9.7	8.8	12.0	11.0	10.1
			sensible	5.9	5.5	5.3	7.6	7.3	6.9	9.1	8.7	8.4
27/19	0.25	11.6	total	8.7	8.1	7.5	10.2	9.5	8.8	11.2	10.4	9.7
			sensible	6.5	6.3	6.1	8.4	8.1	7.9	10.0	9.7	9.4
	0.35	21.0	total	9.8	9.1	8.4	11.8	11.0	10.1	13.2	12.3	11.4
			sensible	7.0	6.7	6.4	9.0	8.7	8.4	10.7	10.4	10.1
	0.45	33.0	total	10.4	9.7	9.0	12.9	12.0	11.1	14.8	13.8	12.7
			sensible	7.2	7.0	6.7	9.5	9.1	8.8	11.3	11.0	10.6

1 row hot water coil

Air on DB	W. flow L/s	P.D. kPa	Heating kW	Entering water temp			Entering water temp			Entering water temp		
				50	65	80	50	65	80	50	65	80
15	0.06	4.8	heat	5.6	8.1	10.5	6.3	9.1	11.7	6.8	9.7	12.6
	0.12	16.3	heat	7.0	10.1	13.1	8.4	12.1	15.7	9.4	13.5	17.5
	0.18	33.4	heat	7.7	11.0	14.4	9.6	13.7	17.7	10.9	15.6	20.2
21	0.06	4.8	heat	4.7	7.1	9.5	5.2	7.9	10.7	5.6	8.5	11.4
	0.12	16.3	heat	5.8	8.8	11.8	7.0	10.6	14.2	7.8	11.8	15.9
	0.18	33.4	heat	6.4	9.6	13.0	7.9	12.0	16.1	8.9	13.6	18.3

Performance Data

IXDL 160Y

Air Handling

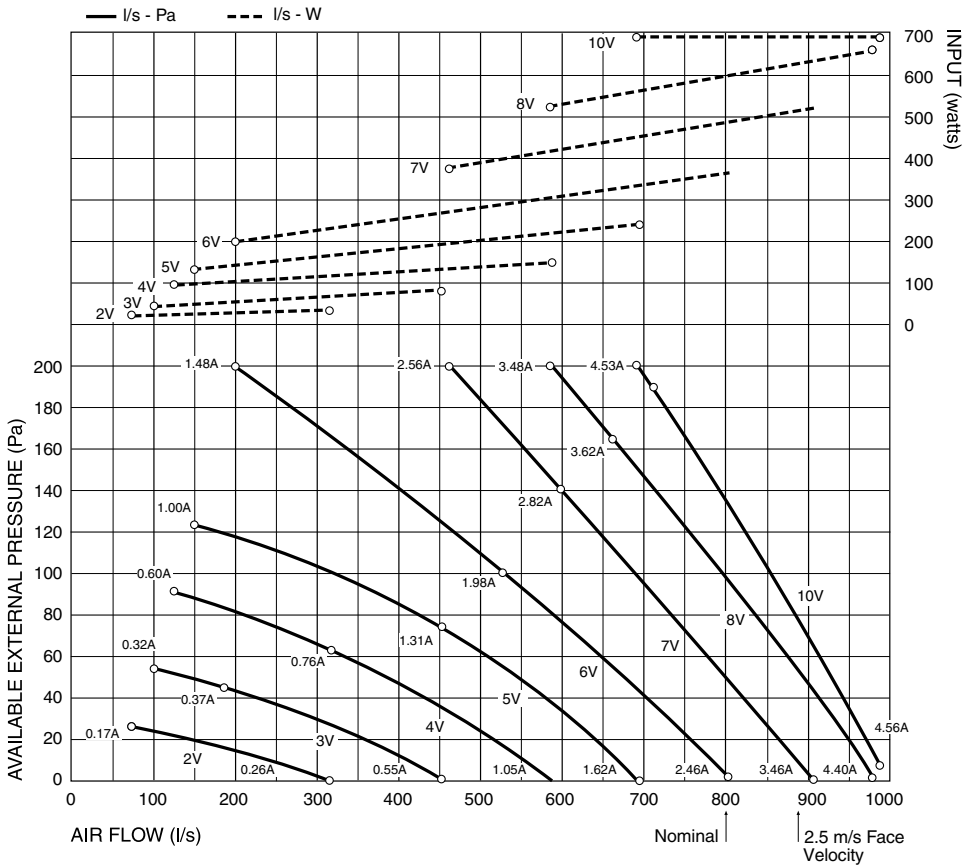

Note: Airflows are for dry coil. Reduce airflow by 10% in high moisture removal conditions.

Air flows given are for IXDL-Y units without filter installed. Refer to page 70 for filter pressure drop.

For **individual fan performance** see page 60 - IXDL 40Y Fan Curve

Sound Levels

Return Air Inlet + Case Breakout							
Vdc	Sound Pressure Levels (SPL) (dB)						
	dB(A)	Octave Band Centre Frequency (Hz)					
		125	250	500	1K	2K	4K
9	70	76	75	68	59	57	53
8	69	75	74	66	58	56	52
7	67	73	72	64	56	53	49
6	64	71	70	61	54	50	45
5	60	67	66	58	50	45	40
4	56	63	61	54	46	40	35
3	50	58	56	48	40	34	30
2	43	52	48	41	33	30	26

Supply Air Outlet							
Vdc	Sound Pressure Levels (SPL) (dB)						
	dB(A)	Octave Band Centre Frequency (Hz)					
		125	250	500	1K	2K	4K
9	67	78	72	60	53	52	49
8	66	78	72	60	52	51	48
7	65	76	70	57	50	49	45
6	62	74	69	54	48	46	42
5	59	70	64	51	45	41	37
4	55	67	60	47	41	36	32
3	49	62	54	41	34	28	23
2	42	55	46	34	26	21	14

Sound levels are specified as in-situ conditions. For more information and adjustment factors for your specific installation please find supplementary booklets under the relevant units on our website www.temperzone.com

IXDL 200-4-Y

				Low Speed			Medium Speed			High Speed		
4 row chilled water coil				500 L/s			750 L/s			1000 L/s		
Air on DB/WB	W. flow L/s	P.D. kPa	Cooling kW	Entering water temp			Entering water temp			Entering water temp		
				6	7	8	6	7	8	6	7	8
23/17	0.2	5.4	total	8.4	7.7	7.1	9.4	8.7	7.9	10.0	9.4	8.8
			sensible	6.6	6.3	6.1	8.5	8.2	7.9	10.0	9.4	8.8
	0.4	18.7	total	10.9	10.0	9.1	13.2	12.1	11.0	14.7	13.5	12.3
			sensible	7.7	7.3	6.9	10.0	9.6	9.1	12.0	11.5	11.0
	0.6	38.9	total	12.1	11.1	10.1	15.2	14.0	12.8	17.6	16.2	14.7
			sensible	8.2	7.8	7.3	10.9	10.4	9.9	13.2	12.6	12.0
27/19	0.2	5.4	total	10.3	9.6	8.9	11.5	10.7	10.0	12.3	11.8	11.2
			sensible	8.3	8.0	7.7	10.6	10.4	10.0	12.3	11.8	11.2
	0.4	18.7	total	13.4	12.5	11.6	16.2	15.0	13.9	17.8	16.8	15.5
			sensible	9.5	9.2	8.8	12.5	12.0	11.6	14.9	14.5	14.0
	0.6	38.9	total	14.8	13.9	12.9	18.7	17.4	16.1	21.5	20.1	18.6
			sensible	10.1	9.7	9.3	13.5	13.0	12.5	16.3	15.8	15.2

IXDL 200-3/1-Y

3 row chilled water coil				500 L/s			750 L/s			1000 L/s		
Air on DB/WB	W. flow L/s	P.D. kPa	Cooling kW	Entering water temp			Entering water temp			Entering water temp		
				6	7	8	6	7	8	6	7	8
23/17	0.25	13.5	total	8.4	7.7	7.0	9.6	8.9	8.1	10.4	9.6	8.9
			sensible	6.4	6.1	5.8	8.1	7.8	7.5	9.6	9.3	8.9
	0.35	24.8	total	9.5	8.7	7.9	11.3	10.3	9.4	12.6	11.6	10.5
			sensible	6.5	6.5	6.2	8.8	8.4	8.0	10.4	10.0	9.6
	0.45	39	total	10.2	9.4	8.6	12.5	11.5	10.4	14.1	13.0	11.8
			sensible	7.1	6.8	6.4	9.3	8.8	8.4	11.0	10.6	10.1
27/19	0.25	13.5	total	10.2	9.6	8.9	11.7	10.9	10.1	12.7	11.9	11.2
			sensible	7.9	7.6	7.3	10.1	9.8	9.5	12.0	11.7	11.2
	0.35	24.8	total	11.6	10.8	10.0	13.7	12.9	11.9	15.4	14.3	13.3
			sensible	8.5	8.1	7.8	10.9	10.5	10.2	13.0	12.6	12.2
	0.45	39	total	12.6	11.7	10.9	15.3	14.3	13.3	17.3	16.1	14.9
			sensible	8.8	8.5	8.1	11.5	11.1	10.7	13.7	13.3	12.8

1 row hot water coil				500 L/s			750 L/s			1000 L/s		
Air on DB	W. flow L/s	P.D. kPa	Heating kW	Entering water temp			Entering water temp			Entering water temp		
				50	65	80	50	65	80	50	65	80
15	0.06	5.6	heat	6.4	9.1	11.9	7.0	10.0	13.1	7.4	10.7	13.7
	0.12	19.4	heat	8.4	12.0	15.6	9.8	14.0	18.3	10.8	15.5	20.2
	0.18	39.4	heat	9.3	13.3	17.3	11.3	16.2	21.1	12.8	18.3	23.9
21	0.06	5.6	heat	5.3	8.0	10.7	5.8	8.8	11.9	6.1	9.3	12.5
	0.12	19.4	heat	6.9	10.5	14.1	8.1	12.3	16.5	9.0	13.6	18.3
	0.18	39.4	heat	7.7	11.7	15.6	9.3	14.2	19.0	10.6	16.1	21.6

Performance Data

IXDL 200Y

Air Handling

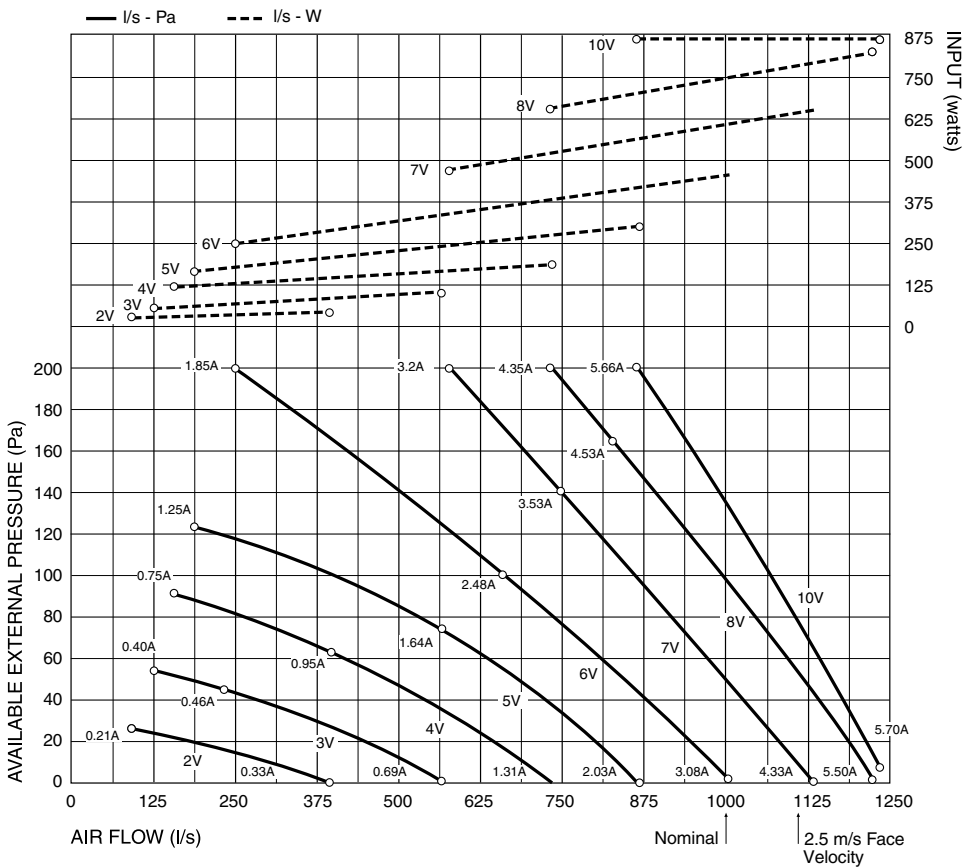

Note: Airflows are for dry coil. Reduce airflow by 10% in high moisture removal conditions.

Air flows given are for IXDL-Y units without filter installed. Refer to page 70 for filter pressure drop.

For **individual fan performance** see page 60 - IXDL 40Y Fan Curve

Sound Levels

Return Air Inlet + Case Breakout							
Vdc	Sound Pressure Levels (SPL) (dB)						
	dB(A)	Octave Band Centre Frequency (Hz)					
		125	250	500	1K	2K	4K
9	71	77	76	68	60	57	54
8	69	76	74	67	59	56	53
7	67	74	72	65	57	53	49
6	66	72	70	62	54	60	46
5	61	68	66	59	51	46	41
4	57	64	62	55	47	41	36
3	51	59	56	49	41	34	30
2	44	53	48	41	34	31	27

Supply Air Outlet							
Vdc	Sound Pressure Levels (SPL) (dB)						
	dB(A)	Octave Band Centre Frequency (Hz)					
		125	250	500	1K	2K	4K
9	68	79	73	61	53	54	50
8	67	78	72	60	53	53	49
7	65	76	70	58	51	50	46
6	63	74	69	55	49	47	43
5	60	71	65	51	45	43	38
4	56	67	61	48	42	38	32
3	50	62	54	41	35	30	24
2	42	55	46	35	27	22	15

Sound levels are specified as in-situ conditions. For more information and adjustment factors for your specific installation please find supplementary booklets under the relevant units on our website www.temperzone.com

Dimensional Data

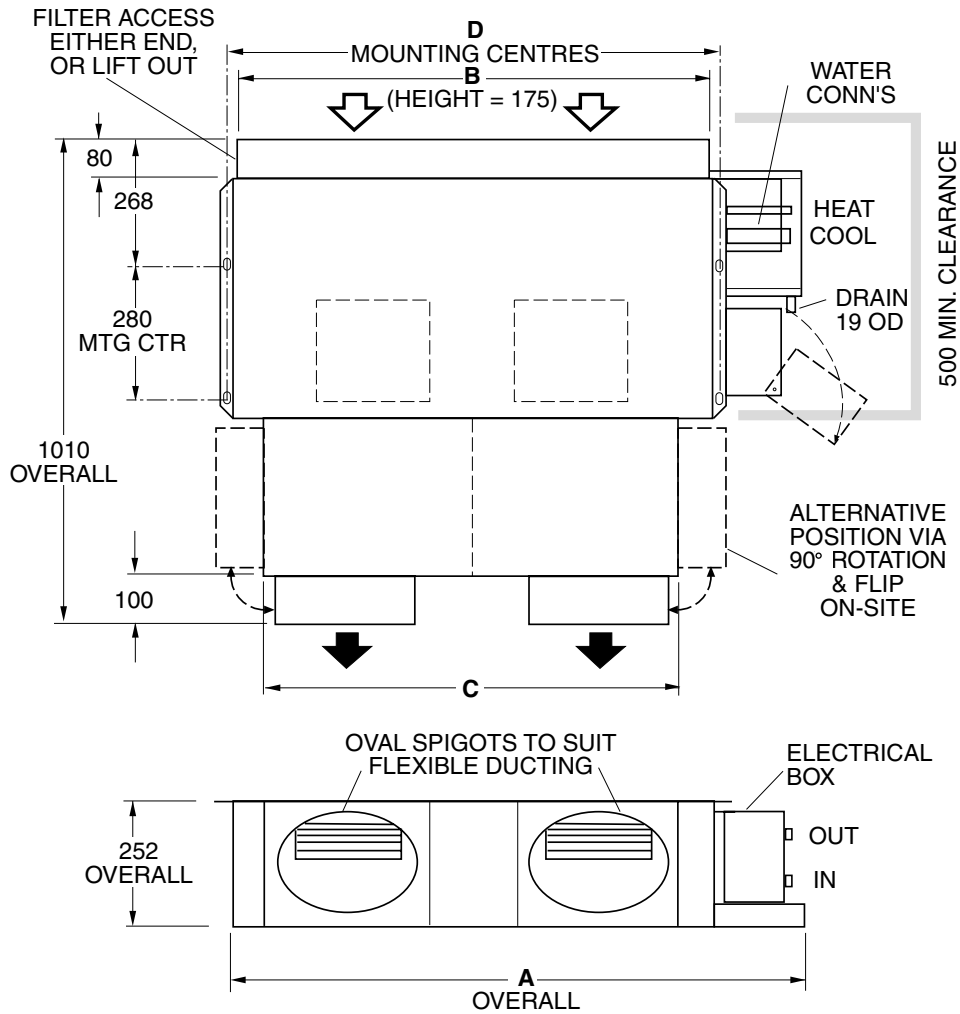

Model IXDL 90Y Shown.

Note:

1. Allow adequate clearance for the filter (if fitted) to be removed.
2. IXDL have two half length filters except for IXDL 40Y.

Model	A	B	C	D	S/A Spigots	Water Conn's BSP Male		No. Fans / Outles / Zones
						Cold	Hot	
IXDL 40Y	706	473	332	529	250 dia (x1)	25	13	1
IXDL 90Y	1250	973	820	1030	250 dia (x2)	25	13	2
IXDL 130Y	1605	1373	1252	1430	250 dia (x3)	25	13	3
IXDL 160Y	1954	1722	1630	1780	250 dia (x4)	25	13	4
IXDL 200Y	2355	2122	2037	2178	250 dia (x5)	25	13	5

Filter Pressure Drop

IMDL & IMD Series - EU2 rated filter media (standard)

G2/EU2

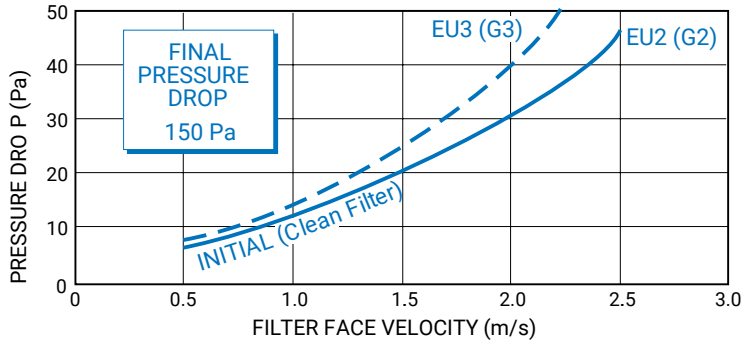

Filter Area	m ²
IMDL 40	0.13m ²
IMDL 60	0.19m ²
IMDL 90	0.25m ²
IMDL 130	0.35m ²
IMD 95	0.163m ²
IMD 135	0.211m ²
IMD 170	0.259m ²
IMD 210	0.293m ²
IMD 280	0.408m ²
IMD 420	0.569m ²
IMDL 550	0.772m ²
IXDL 40Y	0.075m ²
IXDL 90Y	0.15m ²
IXDL 130Y	0.22m ²
IXDL 160Y	0.275m ²
IXDL 200Y	0.34m ²

G4/EU4 - Optional for IJD Series

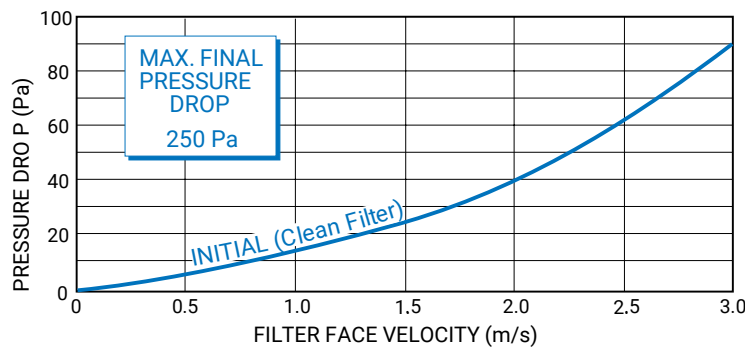

Filter Area	m ²
IJD 370	0.600m ²
IJD 450	0.750m ²
IJD 620	0.937m ²
IJD 950	1.350m ²
IJD 1400	1.900m ²
IJD 2000	3.000m ²
IJD 2400	3.600m ²

Note:

G2/EU2 filters do not meet Australian standards so are not used in the Australian market. G4/EU4 filters, that meet Australian standard, are best located behind return air grilles or in the ducting to reduce the velocity and therefore resistance losses.

Advantage Range (Compact FCU)

IMD



3 Speed Fan Motor



Electric Heating



Opposite Hand



Advantage Range (IMD) Specifications



Model	IMD 95	IMD 135	IMD 170	IMD 210	IMD 280	IMD 420	IMD 550
Nominal Air Flow (l/s) *	450	600	750	900	1200	1800	2350
Fan Type	Forward curved centrifugal double inlet double width						
No. of Fan Scrolls	1	1	1	2	2	2	2
Motor Type	Three speed, direct drive						
Power Source **	1 Phase 230 Volt AC 50 Hz						
No. of Motors	1	1	1	1	2	2	2
Motor Rating (W)	316	373	550	550	550 (x2)	746 (x2)	746 (x2)
Full Load Current (A)**	3.5	3.7	5.0	5.7	5.7 x 2 (11.4)	6.3 x 2 (12.6)	6.3 x 2 (12.6)
Optional Electric Heating (kW)***	4	6	6	9	9	12	18
Electric Heat Current (A/ph)	17.6/1ph	8.8/3ph	8.8/3ph	13.2/3ph	13.2/3ph	17.6/3ph	26.4/3ph
Heat Exchanger Type	Epoxy aluminium corrugated plate fins to expanded rifled copper tube						
Cooling/Heating Medium	Chilled Water or Hot Water						
Finish	Zinc galvanised steel						
Test Pressure	2100 kPa						
Connection Sizes Cooling Coil (mm)	Ø 25 (1" BSP)	Ø 25 (1" BSP)	Ø 25 (1" BSP)	Ø 25 (1" BSP)	Ø 32 (1¼" BSP)	Ø 32 (1¼" BSP)	Ø 32 (1¼" BSP)
Connection Sizes Heating Coil (mm)	Ø 15 (½" BSP)	Ø 15 (½" BSP)	Ø 15 (½" BSP)	Ø 15 (½" BSP)	Ø 25 (1" BSP)	Ø 32 (1¼" BSP)	Ø 32 (1¼" BSP)
Optional Air Filter Type	G2 / EU2 Washable						
No. of optional Air Filters	1	1	1	1	2	2	2
Optional Air Filter Size (mm)	593 x 275 x 13	767 x 275 x 13	914 x 275 x 13	1064 x 275 x 13	593 x 345 x 13	685 x 415 x 13	3712 x 542 x 13
Weight (4/1) Inc. Water (kg)	47	55	62	72	96	135	165
Nett Dry Weight (kg)	42	49	55	64	85	120	145
Shipping Weight (kg)	48	55	62	72	93	147	173

* with no filters fitted and with a dry coil surface

** Voltage fluctuation limits 200-252V fan motor only excluding electric heat

*** Optional Electric Heating - models IMD135 through IMD550 require a 3 phase AC power supply, 342-436V 50Hz

Cooling and Heating Coil options:

4 Row Cooling only

4 Row Cooling + 1 Row Heating

4 Row Cooling plus Electric Heating

IMD 95

				Low Air flow			Medium Air flow			Nominal Air flow		
4 row chilled water coil				250 L/s			350 L/s			450 L/s		
Air on DB/WB	W. flow L/s	P.D. kPa	Cooling kW	Entering water temp			Entering water temp			Entering water temp		
				6	7	8	6	7	8	6	7	8
23/17	0.3	7.0	total	5.4	5.0	4.5	6.4	5.9	5.4	7.2	6.7	6.1
			sensible	3.8	3.6	3.4	4.8	4.6	4.3	5.6	5.4	5.2
	0.5	17.6	total	6.0	5.5	5.0	7.4	6.8	6.1	8.5	7.9	7.1
			sensible	4.1	3.9	3.7	5.2	5.0	4.7	6.2	5.9	5.6
	0.7	32.4	total	6.4	5.8	5.3	8.0	7.3	6.7	9.3	8.6	7.8
			sensible	4.3	4.0	3.8	5.5	5.2	4.9	6.5	6.2	5.9
27/19	0.3	7.0	total	6.6	6.2	5.7	7.9	7.4	6.8	8.8	8.2	7.6
			sensible	4.7	4.5	4.3	5.9	5.7	5.5	7.0	6.8	6.6
	0.5	17.6	total	7.4	6.9	6.4	9.1	8.5	7.9	10.6	9.8	9.0
			sensible	5.1	4.8	4.6	6.5	6.2	5.9	7.7	7.4	7.1
	0.7	32.4	total	7.8	7.3	6.8	9.8	9.2	8.5	11.5	10.7	10.0
			sensible	5.2	5.0	4.8	6.8	6.5	6.2	8.1	7.8	7.5
31/21	0.3	7.0	total	8.0	7.5	7.1	9.4	8.9	8.3	10.5	9.9	8.3
			sensible	5.6	5.4	5.3	7.1	6.9	6.6	8.3	8.1	7.9
	0.5	17.6	total	8.9	8.4	7.9	10.9	10.3	9.6	12.5	11.8	11.1
			sensible	6.0	5.8	5.6	7.7	7.4	7.1	9.1	8.8	8.6
	0.7	32.4	total	9.4	8.9	8.3	11.8	11.1	10.4	13.8	13.0	12.2
			sensible	6.2	6.0	5.8	8.0	7.8	7.5	9.6	9.3	9.0
35/24	0.3	7.0	total	10.1	9.6	9.1	11.8	11.2	10.6	13.1	12.4	11.7
			sensible	6.3	6.1	5.9	7.9	7.7	7.5	9.2	9.0	8.8
	0.5	17.6	total	11.3	10.8	10.2	13.9	13.2	12.5	15.8	15.0	14.2
			sensible	6.8	6.6	6.4	8.6	8.4	8.1	10.2	9.9	9.6
	0.7	32.4	total	12.0	11.5	10.9	15.0	14.3	13.6	17.5	16.6	15.7
			sensible	7.1	6.9	6.6	9.1	8.8	8.5	10.8	10.5	10.2
1 row hot water coil												
Air on DB	W. flow L/s	P.D. kPa	Heating kW	Entering water temp			Entering water temp			Entering water temp		
				50	65	80	50	65	80	50	65	80
7	0.04	1.6	heat	4.2	5.7	7.2	4.7	6.4	7.9	5.0	6.8	8.5
	0.12	10.4	heat	5.6	7.5	9.5	6.6	9.0	11.3	7.5	10.0	12.7
	0.2	25.7	heat	6.1	8.2	10.4	7.4	10.0	12.6	8.4	11.4	14.3
15	0.04	1.6	heat	3.4	4.9	6.4	3.8	5.4	7.1	4.1	5.8	7.6
	0.12	10.4	heat	4.5	6.5	8.4	5.4	7.7	10.0	6.0	8.6	11.2
	0.2	25.7	heat	4.9	7.1	9.2	6.0	8.6	11.1	6.8	9.8	12.7
21	0.04	1.6	heat	2.8	4.3	5.8	3.2	4.8	6.4	3.4	5.1	6.9
	0.12	10.4	heat	3.7	5.7	7.6	4.4	6.7	9.0	5.0	7.6	10.1
	0.2	25.7	heat	4.1	6.2	8.3	5.0	7.5	10.1	5.7	8.6	11.5

Performance Data

IMD 95

Air Handling

Notes:

1. Air flows given are for a unit with no filter installed.
2. In a free blown application, beware of exceeding indoor fan motor's full load amp limit.
3. Airflows are for dry coil. Reduce airflow by 10% in high moisture removal conditions. Refer to page 70 for filter pressure drop.

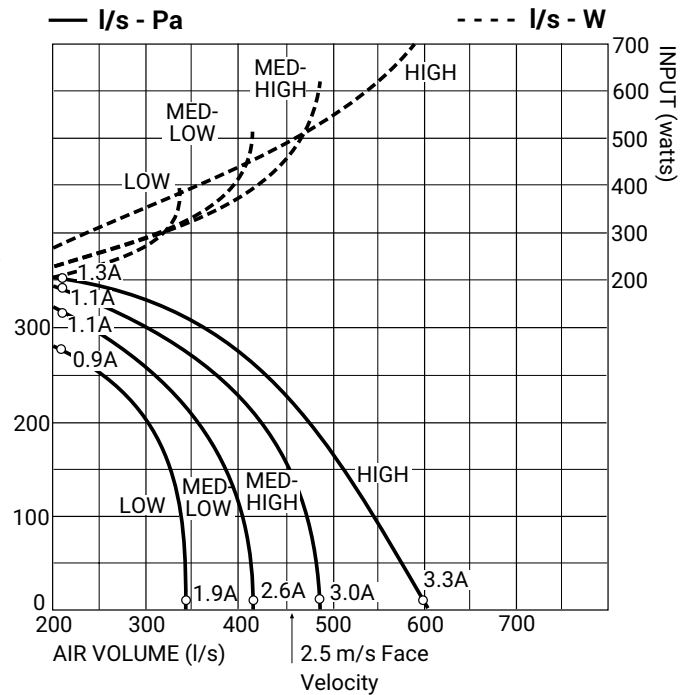

Dimensions

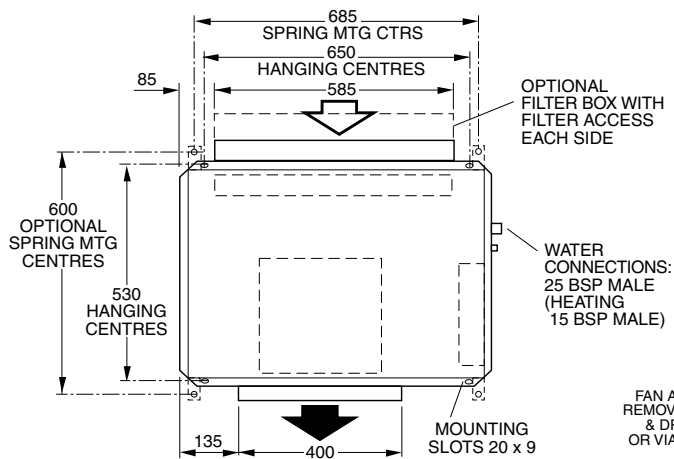

FAN ACCESS VIA REMOVEABLE BASE & DRAIN TRAY. OR VIA TOP PANEL

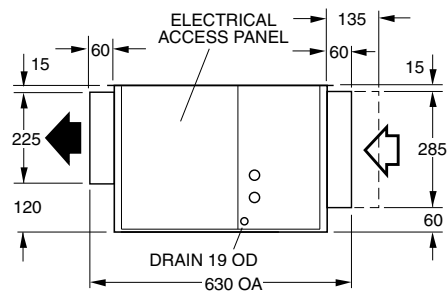
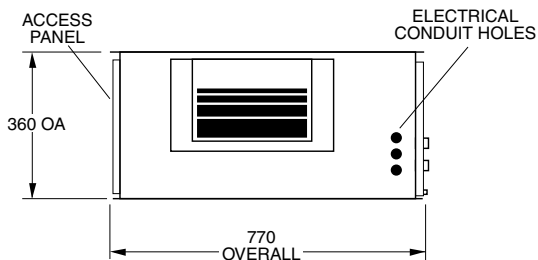

Sound Levels

Sound levels are specified as in-situ conditions. For more information and adjustment factors for your specific installation please find supplementary booklets under the relevant units on our website www.temperzone.com

Fan Speed	Sound Power Levels (SWL) (dB)						
	dB(A)	Octave Band Centre Frequency (Hz)					
		125	250	500	1K	2K	4K
Low	50	58	55	47	39	31	30
Med/Low	55	61	61	51	44	36	36
Med/High	58	66	65	54	47	39	39
High	60	68	67	55	48	42	41

IMD 135

				Low Air flow			Medium Air flow			Nominal Air flow		
4 row chilled water coil				300 L/s			450 L/s			600 L/s		
Air on DB/WB	W. flow L/s	P.D. kPa	Cooling kW	Entering water temp			Entering water temp			Entering water temp		
				6	7	8	6	7	8	6	7	8
23/17	0.2	4.0	total	5.8	5.3	4.9	6.8	6.3	5.7	7.5	6.8	6.3
			sensible	4.3	4.1	3.9	5.6	5.3	5.1	6.6	6.4	6.2
	0.4	13.9	total	7.0	6.4	5.8	8.7	8.0	7.3	10.1	9.2	8.4
			sensible	4.8	4.6	4.3	6.4	6.0	5.7	7.7	7.3	7.0
	0.6	28.9	total	7.5	6.9	6.3	9.8	9.0	8.2	11.5	10.6	9.6
			sensible	5.1	4.8	4.5	6.8	6.5	6.1	8.3	7.9	7.5
27/19	0.2	4.0	total	7.1	6.6	6.2	8.3	7.7	7.2	9.0	8.4	7.9
			sensible	5.3	5.1	4.9	6.9	6.7	6.5	8.3	8.1	7.9
	0.4	13.9	total	8.6	8.0	7.4	10.7	10.0	9.2	12.3	11.4	10.6
			sensible	5.9	5.7	5.5	7.9	7.6	7.3	9.5	9.2	8.9
	0.6	28.9	total	9.3	8.6	8.0	12.0	11.2	10.4	14.1	13.2	12.2
			sensible	6.3	6.0	5.7	8.4	8.1	7.7	10.3	9.9	9.5
31/21	0.2	4.0	total	8.5	8.0	7.5	9.8	9.3	8.7	10.7	10.1	9.5
			sensible	6.3	6.1	5.9	8.2	8.0	7.8	9.9	9.7	9.5
	0.4	13.9	total	10.3	9.7	9.1	12.8	12.1	11.3	14.7	13.8	12.9
			sensible	7.1	6.8	6.6	9.4	9.1	8.8	11.4	11.0	10.7
	0.6	28.9	total	11.1	10.5	9.8	14.4	13.5	12.7	16.9	15.9	14.9
			sensible	7.4	7.1	6.9	10.0	9.7	9.3	12.2	11.8	11.4
35/24	0.2	4.0	total	10.6	10.1	9.6	12.1	11.6	11.0	13.1	12.5	11.9
			sensible	7.0	6.9	6.7	9.1	8.9	8.7	10.9	10.7	10.5
	0.4	13.9	total	13.0	12.5	11.8	16.1	15.3	14.5	18.2	17.3	16.4
			sensible	8.0	7.7	7.5	10.5	10.2	9.9	12.5	12.2	11.9
	0.6	28.9	total	14.2	13.6	12.9	18.3	17.4	16.5	21.3	20.2	19.2
			sensible	8.5	8.2	7.9	11.3	10.9	10.6	13.6	13.3	12.9

1 row hot water coil				Entering water temp			Entering water temp			Entering water temp		
Air on DB	W. flow L/s	P.D. kPa	Heating kW	50	65	80	50	65	80	50	65	80
				7	0.04	2.0	heat	4.9	6.6	8.2	5.4	7.3
0.12	13.5	heat	6.7		9.1	11.4	8.2	11.1	14.0	9.3	12.5	15.8
0.2	33.3	heat	7.4		10.0	12.6	9.3	12.6	15.9	10.8	14.5	18.3
15	0.04	2.0	heat	4.0	5.7	7.3	4.4	6.3	8.2	4.7	6.7	8.7
	0.12	13.5	heat	5.5	7.8	10.1	6.7	9.5	12.4	7.6	10.8	14.0
	0.2	33.3	heat	6.0	8.6	11.2	7.54	10.8	14.0	8.7	12.5	16.2
21	0.04	2.0	heat	3.3	5.0	6.6	3.6	5.5	7.4	3.9	5.9	7.8
	0.12	13.5	heat	4.5	6.8	9.2	5.5	8.4	11.2	6.2	9.5	12.7
	0.2	33.3	heat	5.0	7.5	10.1	6.2	9.4	12.7	7.2	10.9	14.7

Performance Data

IMD 135

Air Handling

Notes:

1. Air flows given are for a unit with no filter installed.
2. In a free blown application, beware of exceeding indoor fan motor's full load amp limit.
3. Airflows are for dry coil. Reduce airflow by 10% in high moisture removal conditions. Refer to page 70 for filter pressure drop.

Dimensions

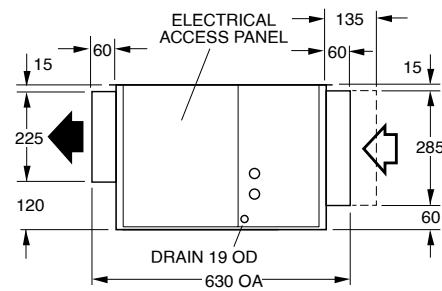
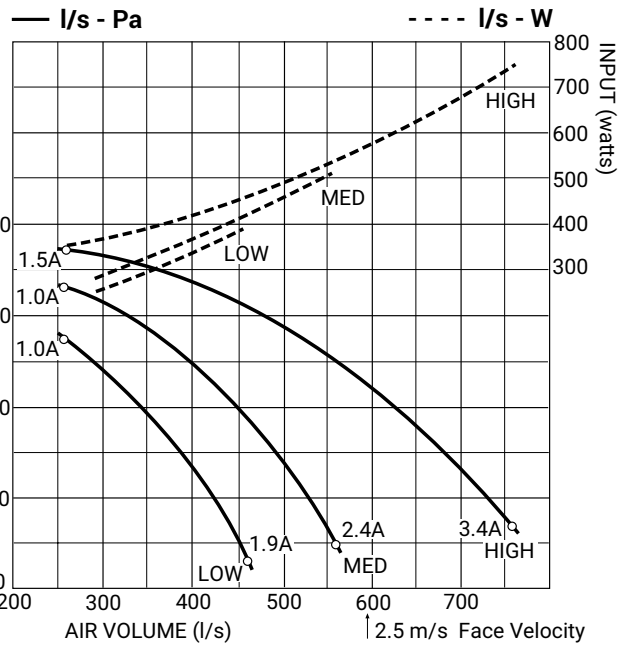
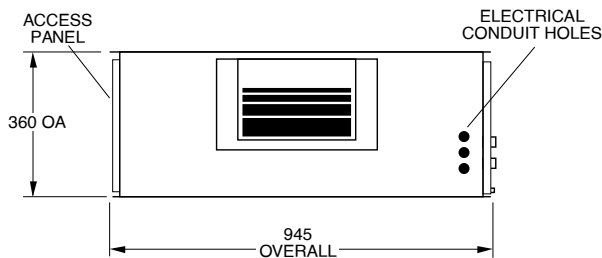
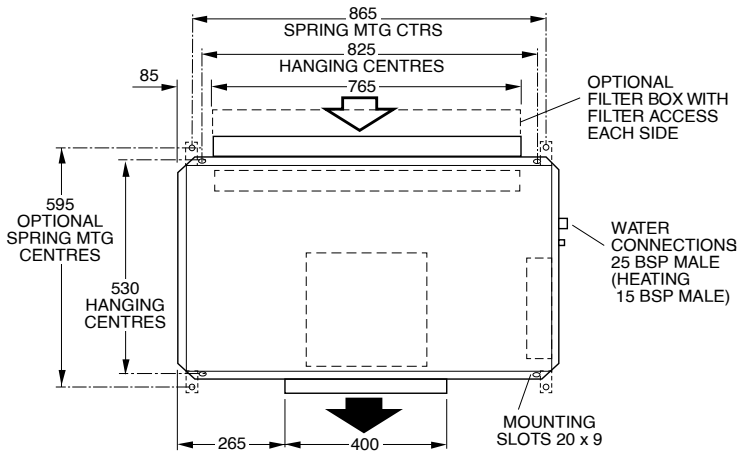

Sound Levels

Sound levels are specified as in-situ conditions. For more information and adjustment factors for your specific installation please find supplementary booklets under the relevant units on our website www.temperzone.com

Fan Speed	Sound Power Levels (SWL) (dB)						
	dB(A)	Octave Band Centre Frequency (Hz)					
		125	250	500	1K	2K	4K
Low	50	58	56	46	37	31	30
Med	54	61	61	51	42	36	36
High	60	67	67	56	49	42	42

IMD 170

				Low Air flow			Medium Air flow			Nominal Air flow		
4 row chilled water coil				350 L/s			550 L/s			750 L/s		
Air on DB/WB	W. flow L/s	P.D. kPa	Cooling kW	Entering water temp			Entering water temp			Entering water temp		
				6	7	8	6	7	8	6	7	8
23/17	0.3	9.3	total	7.5	6.9	6.3	9.2	8.5	7.7	10.3	9.5	8.8
			sensible	5.3	5.1	4.8	7.2	6.8	6.5	8.7	8.4	8.0
	0.45	19.4	total	8.3	7.6	6.9	10.6	9.7	8.9	12.3	11.3	10.3
			sensible	5.7	5.4	5.1	7.7	7.4	7.0	9.5	9.1	8.6
	0.6	33.4	total	8.8	8.0	7.3	11.6	10.6	9.7	13.8	12.6	11.5
			sensible	5.9	5.6	5.2	8.2	7.8	7.4	10.1	9.6	9.2
27/19	0.3	9.3	total	9.2	8.6	8.0	11.2	10.5	9.7	12.6	11.8	11.0
			sensible	6.6	6.3	6.1	8.9	8.6	8.3	10.8	10.5	10.2
	0.45	19.4	total	10.2	9.5	8.8	13.1	12.2	11.3	15.1	14.0	13.0
			sensible	7.0	6.7	6.4	9.6	9.3	8.9	11.8	11.4	11.0
	0.6	33.4	total	10.8	10.0	9.3	14.2	13.3	12.3	16.9	15.7	14.6
			sensible	7.3	7.0	6.6	10.1	9.7	9.3	12.5	12.0	11.6
31/21	0.3	9.3	total	11.0	10.4	9.8	13.4	12.7	11.9	15.0	14.1	13.3
			sensible	7.8	7.6	7.3	10.6	10.3	10.0	12.9	12.6	12.3
	0.45	19.4	total	12.2	11.5	10.8	15.6	14.7	13.8	18.0	16.9	15.9
			sensible	8.3	8.0	7.8	11.4	11.1	10.7	14.0	13.6	13.2
	0.6	33.4	total	12.9	12.2	11.4	17.0	16.0	15.0	20.2	18.9	17.8
			sensible	8.6	8.3	8.0	12.0	11.6	11.2	14.8	14.4	13.9
35/24	0.3	9.3	total	13.9	13.2	12.5	16.7	15.8	15.0	18.4	17.5	16.6
			sensible	8.8	8.5	8.3	11.7	11.4	11.1	14.2	13.9	13.6
	0.45	19.4	total	15.5	14.8	14.0	19.6	18.6	17.7	22.4	21.3	20.2
			sensible	9.4	9.1	8.8	12.7	12.4	12.1	15.5	15.1	14.8
	0.6	33.4	total	16.5	15.7	15.0	21.6	20.6	19.5	25.2	23.9	22.7
			sensible	9.8	9.5	9.2	13.5	13.1	12.7	16.5	16.0	15.6

1 row heating water coil				Entering water temp			Entering water temp			Entering water temp		
Air on DB	W. flow L/s	P.D. kPa	Heating kW	50	65	80	50	65	80	50	65	80
				7	0.06	4.5	heat	6.4	8.6	10.8	7.3	9.9
0.12	13.4	heat	7.8		10.5	13.2	9.5	12.9	16.2	10.8	14.6	18.3
0.18	31.4	heat	8.5		11.4	14.6	10.7	14.4	18.2	12.4	16.7	21.0
15	0.06	4.5	heat	5.2	7.4	9.6	5.9	8.5	11.0	6.4	9.2	11.9
	0.12	15.4	heat	6.3	9.0	11.7	7.7	11.1	14.4	8.8	12.5	16.3
	0.18	31.4	heat	7.0	9.8	12.7	8.7	12.4	16.1	10.0	14.4	18.7
21	0.06	4.5	heat	4.3	6.4	8.7	4.9	7.4	10.0	5.3	8.1	10.9
	0.12	15.4	heat	5.2	7.9	10.5	6.4	9.7	13.0	7.3	11.0	14.8
	0.18	31.4	heat	5.6	8.6	11.5	7.2	10.9	14.6	8.3	12.6	16.9

Performance Data

IMD 170

Air Handling

Notes:

1. Air flows given are for a unit with no filter installed.
2. In a free blown application, beware of exceeding indoor fan motor's full load amp limit.
3. Airflows are for dry coil. Reduce airflow by 10% in high moisture removal conditions. Refer to page 70 for filter pressure drop.

Dimensions

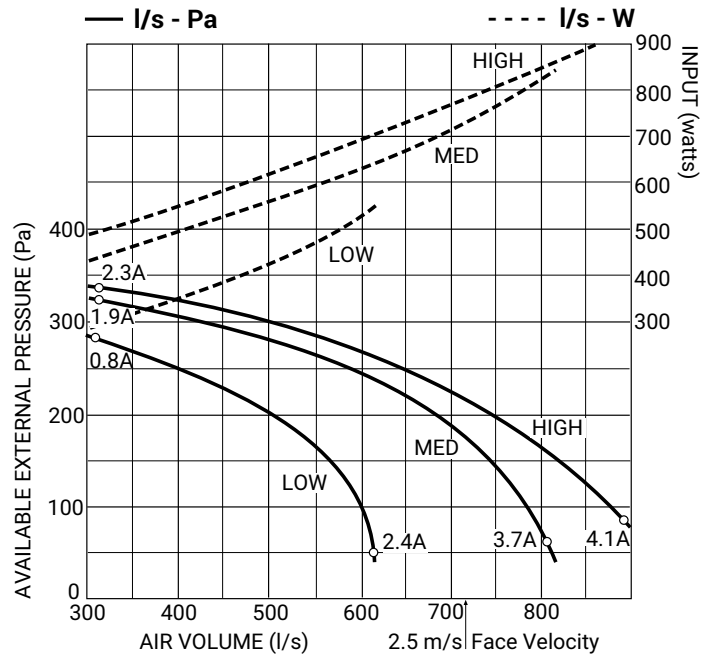
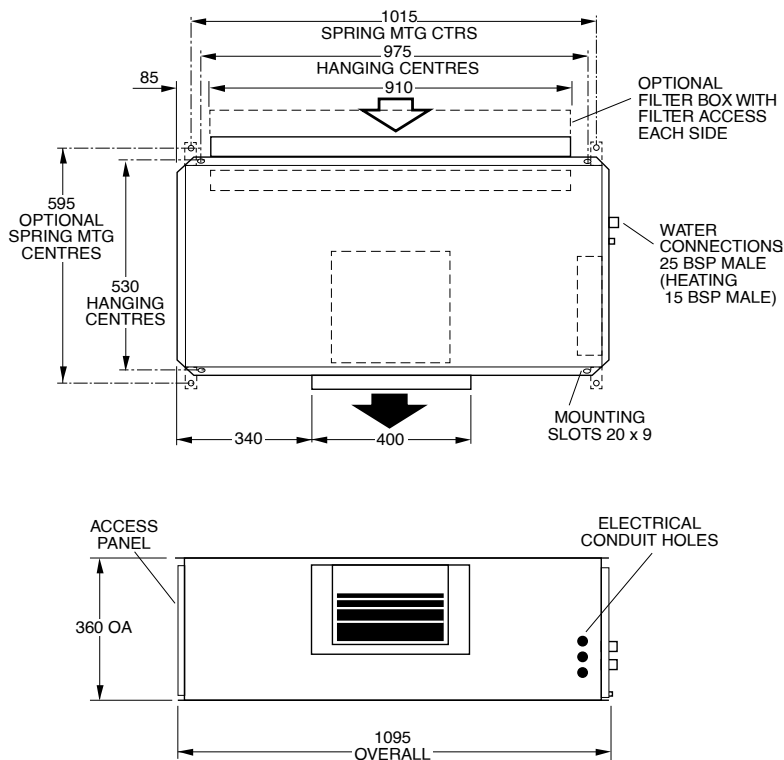

FAN ACCESS VIA REMOVEABLE BASE & DRAIN TRAY, OR VIA TOP PANEL

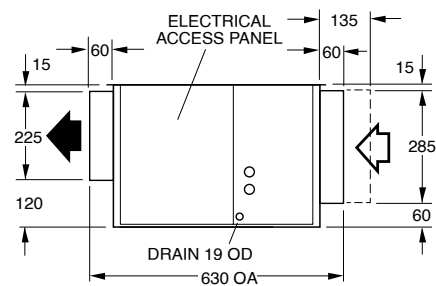

Sound Levels

Sound levels are specified as in-situ conditions. For more information and adjustment factors for your specific installation please find supplementary booklets under the relevant units on our website www.temperzone.com

Fan Speed	Sound Power Levels (SWL) (dB)					
	dB(A)	Octave Band Centre Frequency (Hz)				
		125	250	500	1K	2K
Low	54	57	59	54	44	37
Med	61	63	66	59	53	45
High	63	65	69	61	56	47

IMD 210

				Low Air flow			Medium Air flow			Nominal Air flow		
4 row chilled water coil				400 L/s			650 L/s			900 L/s		
Air on DB/WB	W. flow L/s	P.D. kPa	Cooling kW	Entering water temp			Entering water temp			Entering water temp		
				6	7	8	6	7	8	6	7	8
23/17	0.4	9.5	total	8.9	8.2	7.5	11.3	10.3	9.4	12.8	11.8	10.7
			sensible	6.2	5.9	5.6	8.6	8.2	7.8	10.6	10.1	9.7
	0.6	19.6	total	9.7	8.9	8.1	12.9	11.8	10.8	15.2	13.9	12.7
			sensible	6.6	6.2	5.9	9.3	8.8	8.4	11.5	11.0	10.5
	0.8	33.5	total	10.2	9.4	8.6	14.0	12.8	11.7	16.8	15.4	14.0
			sensible	6.8	6.5	6.1	9.8	9.3	8.8	12.2	11.6	11.0
27/19	0.4	9.5	total	10.9	10.2	9.4	13.8	12.9	11.9	15.6	14.7	13.6
			sensible	7.7	7.4	7.1	10.7	10.3	9.9	13.1	12.8	12.4
	0.6	19.6	total	11.9	11.1	10.4	15.8	14.8	13.7	18.6	17.3	16.1
			sensible	8.2	7.8	7.5	11.5	11.1	10.6	14.3	13.8	13.3
	0.8	33.5	total	12.6	10.7	10.9	17.2	16.0	14.8	20.6	19.2	17.7
			sensible	8.5	8.1	7.7	12.1	11.6	11.1	15.1	14.5	14.0
31/21	0.4	9.5	total	13.1	12.3	11.6	16.4	15.5	14.5	18.6	17.6	16.4
			sensible	9.2	8.9	8.5	12.7	12.3	12.0	15.7	15.3	14.9
	0.6	19.6	total	14.3	13.6	12.7	19.0	17.9	16.7	22.2	20.8	19.7
			sensible	9.7	9.4	9.0	13.7	13.3	12.8	17.0	16.5	16.1
	0.8	33.5	total	15.1	14.3	13.4	20.6	19.4	18.2	24.6	23.1	21.8
			sensible	10.0	9.7	9.3	14.3	13.9	13.4	17.9	17.4	16.9
35/24	0.4	9.5	total	16.6	15.8	14.9	20.5	19.5	18.5	22.9	21.8	20.5
			sensible	10.3	10.0	9.7	14.1	13.7	13.4	17.2	16.9	16.6
	0.6	19.6	total	18.3	17.4	16.5	23.8	22.7	21.5	27.6	26.3	24.9
			sensible	11.0	10.7	10.3	15.3	14.9	14.4	18.8	18.4	17.9
	0.8	33.5	total	19.3	18.4	17.5	26.1	24.9	23.6	30.9	29.4	27.8
			sensible	11.4	11.0	10.7	16.2	15.7	15.2	20.0	19.5	18.9

1 row hot water coil				Entering water temp			Entering water temp			Entering water temp		
Air on DB	W. flow L/s	P.D. kPa	Heating kW	50	65	80	50	65	80	50	65	80
7	0.08	8.4	heat	7.8	10.5	13.2	9.2	12.4	15.6	10.1	13.6	17.1
	0.12	17.3	heat	8.7	11.7	14.7	10.8	14.5	18.3	12.2	16.4	20.7
	0.16	28.8	heat	9.3	12.6	15.8	11.8	16.0	20.1	13.6	18.3	23.0
15	0.08	8.4	heat	6.3	9.0	11.7	7.4	10.6	13.9	8.2	11.7	15.2
	0.12	17.3	heat	7.1	10.1	13.1	8.7	12.5	16.2	9.9	14.1	18.3
	0.16	28.8	heat	7.7	10.8	14.0	9.6	13.7	17.8	11.0	15.7	20.4
21	0.08	8.4	heat	5.2	7.9	10.6	6.2	9.4	12.5	6.8	10.3	13.8
	0.12	17.3	heat	5.8	8.8	11.8	7.2	11.0	14.7	8.2	12.4	16.6
	0.16	28.8	heat	6.4	9.5	12.7	8.2	12.0	16.1	9.1	13.8	18.5

Performance Data

IMD 210

Air Handling

Notes:

1. Air flows given are for a unit with no filter installed.
2. In a free blown application, beware of exceeding indoor fan motor's full load amp limit.
3. Airflows are for dry coil. Reduce airflow by 10% in high moisture removal conditions. Refer to page 70 for filter pressure drop.

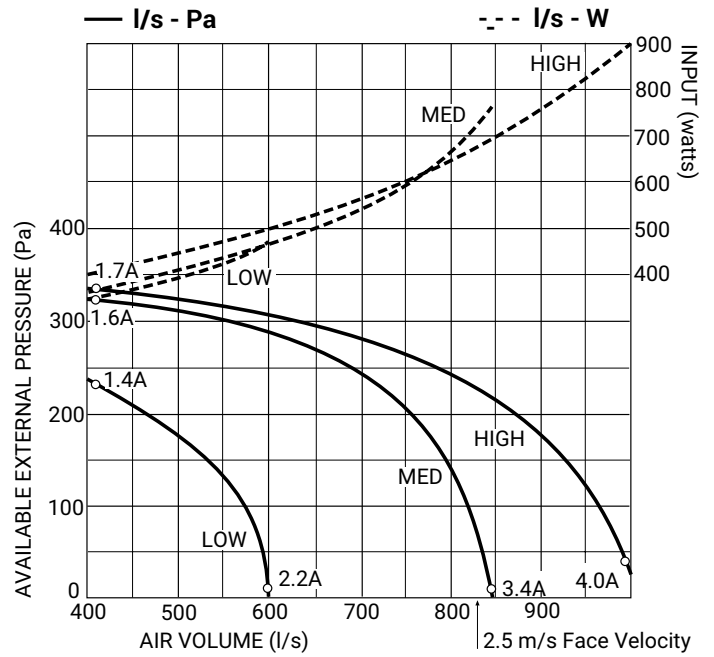

Dimensions

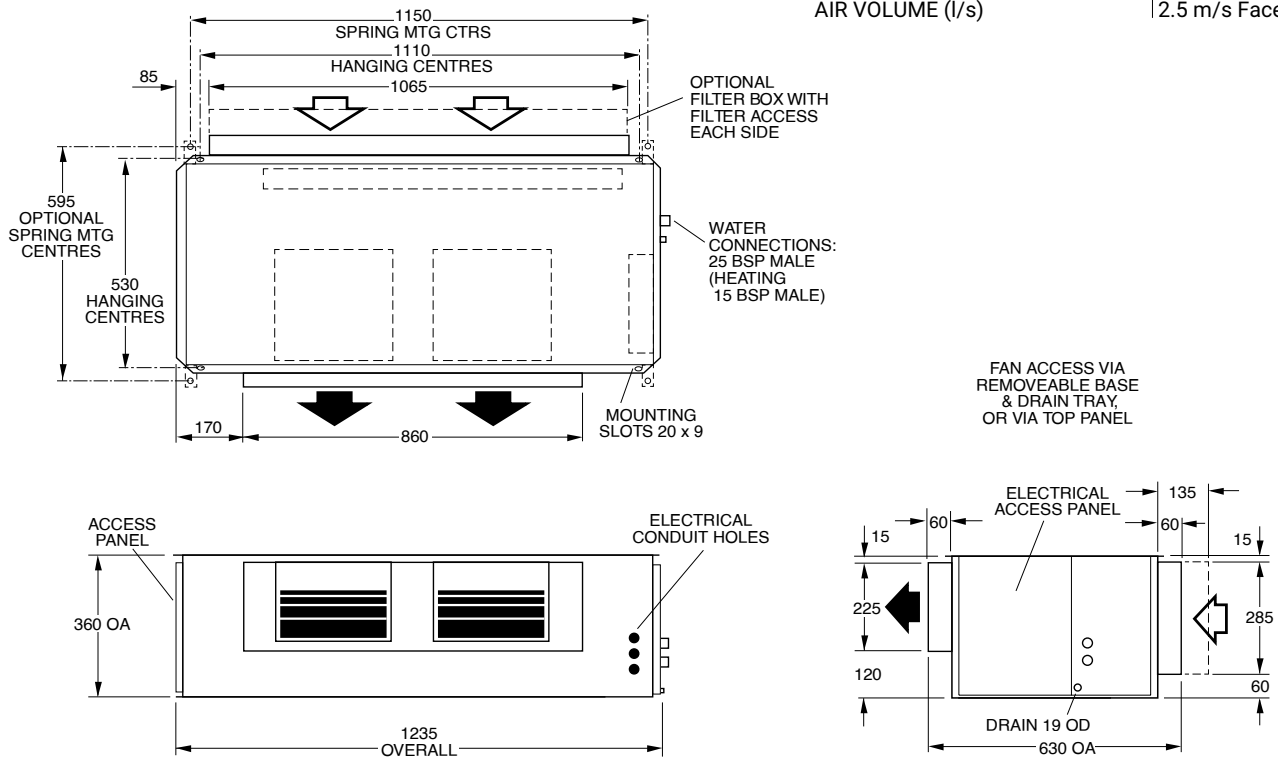

Sound Levels

Sound levels are specified as in-situ conditions. For more information and adjustment factors for your specific installation please find supplementary booklets under the relevant units on our website www.temperzone.com

Fan Speed	Sound Power Levels (SWL) (dB)						
	dB(A)	Octave Band Centre Frequency (Hz)					
		125	250	500	1K	2K	4K
Low	51	54	54	51	41	34	31
Med	57	61	62	56	50	42	41
High	61	64	65	59	55	46	45

IMD 280

				Low Air flow			Medium Air flow			Nominal Air flow		
4 row chilled water coil				600 L/s			900 L/s			1200 L/s		
Air on DB/WB	W. flow L/s	P.D. kPa	Cooling kW	Entering water temp			Entering water temp			Entering water temp		
				6	7	8	6	7	8	6	7	8
23/17	0.6	7.0	total	12.8	11.7	10.7	15.5	14.2	13.0	17.4	16.0	14.6
			sensible	9.1	8.6	8.2	11.9	11.3	10.8	14.2	13.7	13.1
	1.0	17.8	total	14.5	13.2	12.0	18.3	16.8	15.3	21.2	19.5	17.7
			sensible	9.8	9.3	8.7	13.0	12.4	11.7	15.8	15.0	14.3
	1.4	33.1	total	15.2	13.9	12.7	19.9	18.3	16.6	23.6	21.7	19.7
			sensible	10.2	9.6	9.1	13.7	13.0	12.3	16.8	16.0	15.2
27/19	0.6	7.0	total	15.7	14.6	13.5	19.0	17.7	16.4	21.2	19.8	18.4
			sensible	11.2	10.8	10.3	14.7	14.2	13.7	17.7	17.2	16.6
	1.0	17.8	total	17.7	16.5	15.3	22.4	20.9	19.3	26.0	24.2	22.4
			sensible	12.1	11.6	11.1	16.1	15.5	14.9	19.6	18.9	18.2
	1.4	33.1	total	18.7	17.4	16.2	24.4	22.8	21.1	29.0	27.0	25.0
			sensible	12.6	12.0	11.4	17.0	16.3	15.6	20.8	20.0	19.2
31/21	0.6	7.0	total	18.8	17.7	16.6	22.7	21.3	20.0	25.4	23.9	22.4
			sensible	13.4	12.9	12.5	17.5	17.0	16.5	21.1	20.6	20.0
	1.0	17.8	total	21.2	20.0	18.7	26.9	25.3	23.7	31.1	29.3	27.5
			sensible	14.4	13.9	13.3	19.2	18.5	17.9	23.3	22.6	21.9
	1.4	33.1	total	22.5	21.2	19.9	29.3	27.6	25.9	34.7	32.7	30.6
			sensible	14.9	14.4	13.8	20.2	19.5	18.8	24.7	23.9	23.1
35/24	0.6	7.0	total	23.7	22.5	21.4	28.3	26.9	25.5	31.4	29.8	28.3
			sensible	15.0	14.5	14.1	19.4	19.0	18.5	23.3	22.8	22.3
	1.0	17.8	total	26.9	25.7	24.3	33.9	32.2	30.6	38.9	37.0	35.0
			sensible	16.3	15.7	15.2	21.5	20.9	20.2	25.9	25.2	24.5
	1.4	33.1	total	28.7	27.4	26.1	37.2	35.6	33.7	43.8	41.7	39.5
			sensible	17.0	16.5	15.9	22.7	22.1	21.4	26.6	26.9	26.1

1 row hot water coil				Entering water temp			Entering water temp			Entering water temp		
Air on DB	W. flow L/s	P.D. kPa	Heating kW	50	65	80	50	65	80	50	65	80
				7	0.2	2.8	heat	12.5	16.9	21.2	14.8	20.0
0.4	9.6	heat	14.1		19.0	23.9	17.5	23.6	29.7	20.1	27.1	34.1
0.6	20.2	heat	15.0		20.2	25.4	18.9	25.6	32.2	22.1	29.8	37.5
15	0.2	2.8	heat	9.9	15.1	18.5	11.8	16.9	22.0	13.3	18.9	24.6
	0.4	9.6	heat	12.2	17.0	20.8	13.9	19.9	25.9	16.0	22.9	29.8
	0.6	20.2	heat	13.0	18.1	22.1	15.1	21.5	28.0	17.6	25.2	32.7
21	0.2	2.8	heat	8.2	12.5	16.8	9.8	14.9	19.9	10.9	16.6	22.3
	0.4	9.6	heat	9.3	14.0	18.8	11.5	17.5	23.4	13.2	20.1	26.9
	0.6	20.2	heat	9.8	14.9	20.0	12.5	18.9	25.3	14.5	22.1	29.6

Performance Data

IMD 280

Air Handling

Notes:

1. Air flows given are for a unit with no filter installed.
2. In a free blown application, beware of exceeding indoor fan motor's full load amp limit.
3. Airflows are for dry coil. Reduce airflow by 10% in high moisture removal conditions. Refer to page 70 for filter pressure drop.

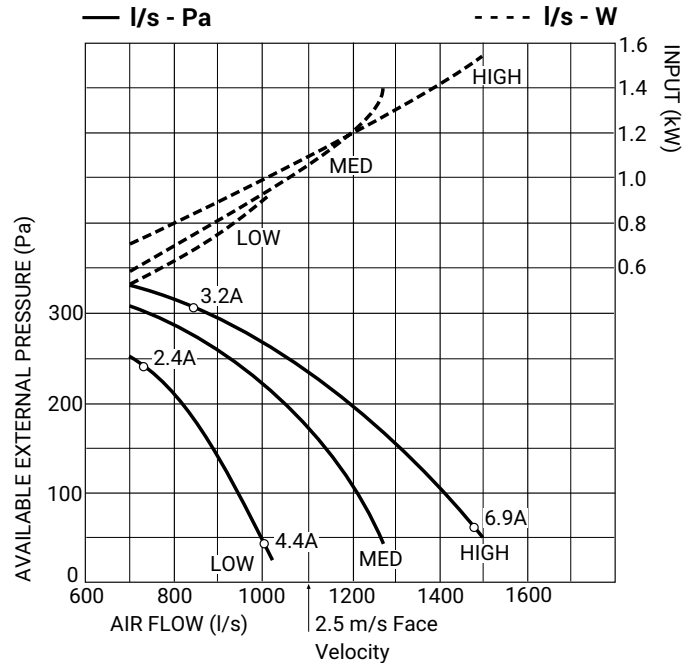

Dimensions

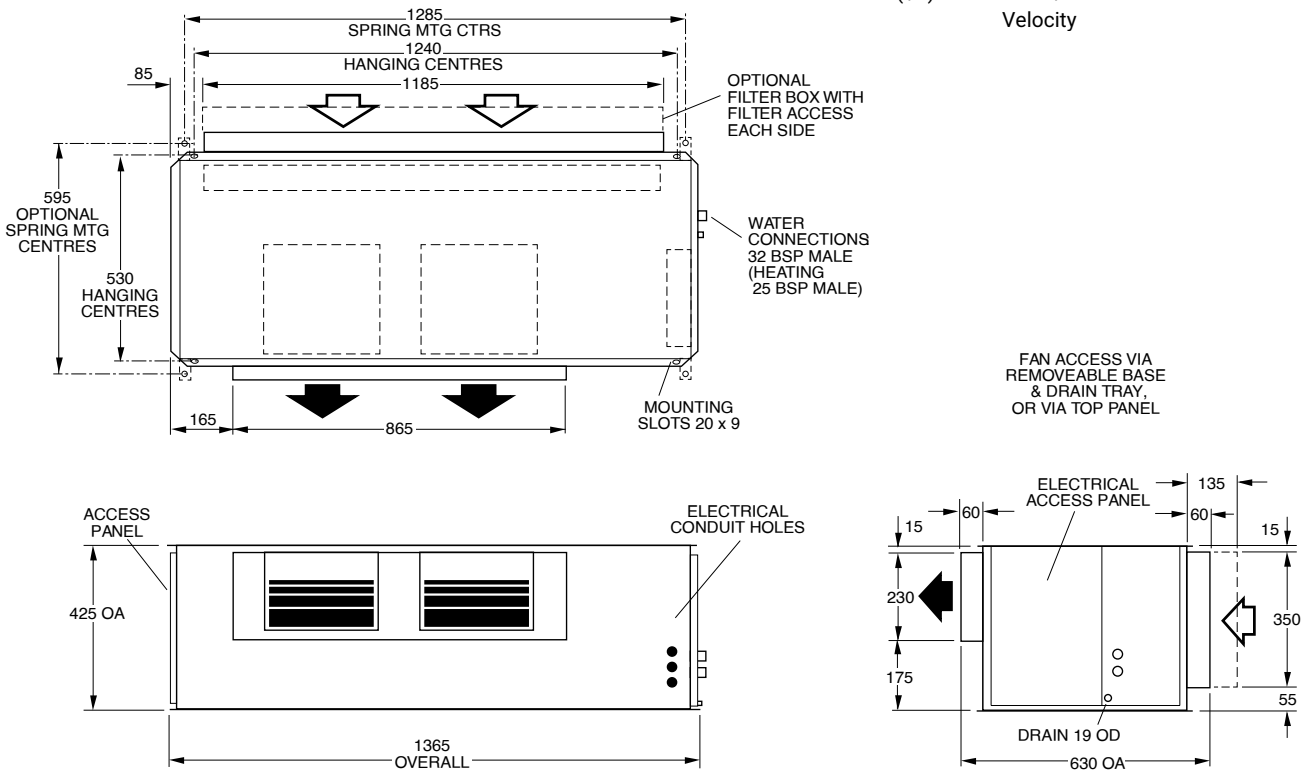

Sound Levels

Sound levels are specified as in-situ conditions. For more information and adjustment factors for your specific installation please find supplementary booklets under the relevant units on our website www.temperzone.com

Fan Speed	Sound Power Levels (SWL) (dB)						
	dB(A)	Octave Band Centre Frequency (Hz)					
		125	250	500	1K	2K	4K
Low	54	61	58	50	47	42	39
Med	58	65	62	54	51	46	43
High	59	66	63	55	52	47	45

IMD 420

				Low Air flow			Medium Air flow			Nominal Air flow		
4 row chilled water coil				1000 L/s			1400 L/s			1800 L/s		
Air on DB/WB	W. flow L/s	P.D. kPa	Cooling kW	Entering water temp			Entering water temp			Entering water temp		
				6	7	8	6	7	8	6	7	8
23/17	1.0	3.9	total	20.4	18.8	17.1	23.9	21.9	19.9	26.4	24.4	22.2
			sensible	14.7	14.0	13.3	18.3	17.5	16.7	21.5	20.7	19.8
	2.0	13.9	total	23.8	21.9	19.9	29.2	26.8	24.4	33.6	31.1	28.2
			sensible	16.2	15.4	14.5	20.6	19.6	18.6	24.5	23.4	22.2
	3.0	29.8	total	25.3	23.3	21.2	32.0	29.3	26.7	37.4	34.5	31.2
			sensible	16.9	16.0	15.1	21.8	20.7	19.5	26.1	24.8	23.4
27/19	1.0	3.9	total	25.0	23.3	21.6	29.1	27.2	25.2	32.1	30.2	27.9
			sensible	18.2	17.5	16.8	22.8	22.0	21.2	26.7	26.0	25.1
	2.0	13.9	total	29.3	27.3	25.3	35.8	33.4	30.9	41.6	38.6	35.6
			sensible	20.0	19.2	18.3	25.5	24.5	23.5	30.5	29.3	28.1
	3.0	29.8	total	31.2	29.1	27.0	39.4	36.7	34.0	46.2	43.1	40.1
			sensible	20.9	20.0	19.1	27.0	25.9	24.7	32.4	31.1	29.9
31/21	1.0	3.9	total	29.9	28.2	26.5	34.8	32.8	30.7	38.6	36.0	34.0
			sensible	21.6	20.9	20.3	27.1	26.3	25.6	32.0	31.0	30.3
	2.0	13.9	total	35.1	33.1	31.0	43.0	40.5	38.0	49.5	46.4	43.7
			sensible	23.8	23.0	22.1	30.3	29.3	28.3	36.1	34.9	33.9
	3.0	29.8	total	37.5	35.3	33.2	47.3	44.6	41.8	55.3	52.3	49.2
			sensible	24.9	23.9	23.0	32.2	31.0	29.8	38.4	37.2	36.0
35/24	1.0	3.9	total	37.7	35.9	34.0	43.4	41.3	39.1	47.4	45.1	42.8
			sensible	24.2	23.5	22.9	30.0	29.3	28.6	35.1	34.4	33.6
	2.0	13.9	total	44.6	42.5	40.6	54.5	51.8	49.2	62.1	59.0	56.0
			sensible	27.0	26.1	25.3	34.1	33.1	32.1	40.2	39.1	38.0
	3.0	29.8	total	48.1	45.9	43.6	60.1	57.3	54.4	70.2	66.7	63.2
			sensible	28.4	27.5	26.5	36.3	35.2	34.0	43.2	41.9	40.7
1 row hot water coil												
Air on DB	W. flow L/s	P.D. kPa	Heating kW	Entering water temp			Entering water temp			Entering water temp		
				50	65	80	50	65	80	50	65	80
7	0.3	3.9	heat	20.0	27.0	34.0	23.1	31.1	39.2	25.4	34.3	43.2
	0.6	12.2	heat	22.9	30.9	38.9	27.5	37.1	46.7	31.0	41.8	52.6
	0.9	27.4	heat	24.5	33.0	41.5	29.8	40.3	50.7	34.1	46.0	57.9
15	0.3	3.9	heat	16.2	23.2	30.1	18.7	26.7	34.8	20.7	29.5	38.4
	0.6	12.2	heat	18.5	26.5	34.4	22.3	31.8	41.4	25.1	35.9	46.6
	0.9	27.4	heat	19.8	28.3	36.8	24.2	34.5	44.9	27.6	39.5	51.3
21	0.3	3.9	heat	13.4	20.3	27.3	15.5	23.5	31.5	17.0	25.9	34.7
	0.6	12.2	heat	15.3	23.2	31.1	18.4	27.9	37.4	20.7	31.5	42.2
	0.9	27.4	heat	16.3	24.8	33.2	19.9	30.2	40.5	22.8	34.6	46.4

Performance Data

IMD 420

Air Handling

Notes:

1. Air flows given are for a unit with no filter installed.
2. In a free blown application, beware of exceeding indoor fan motor's full load amp limit.
3. Airflows are for dry coil. Reduce airflow by 10% in high moisture removal conditions. Refer to page 70 for filter pressure drop.

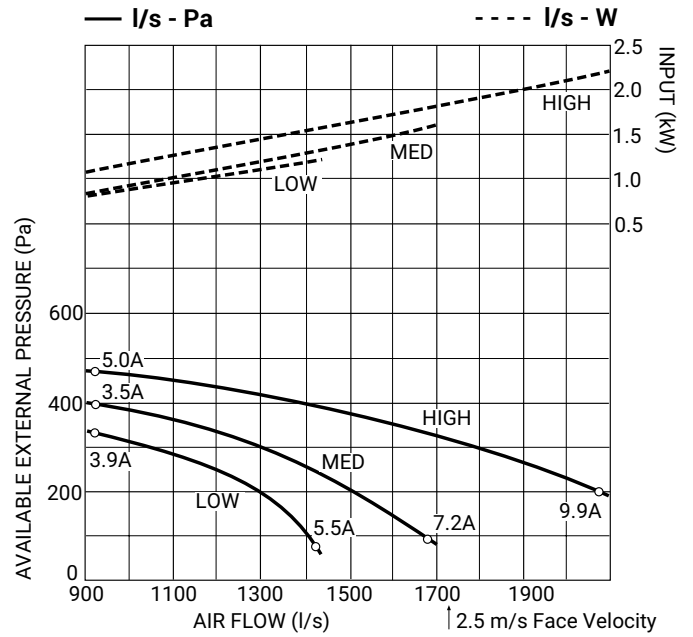

Dimensions

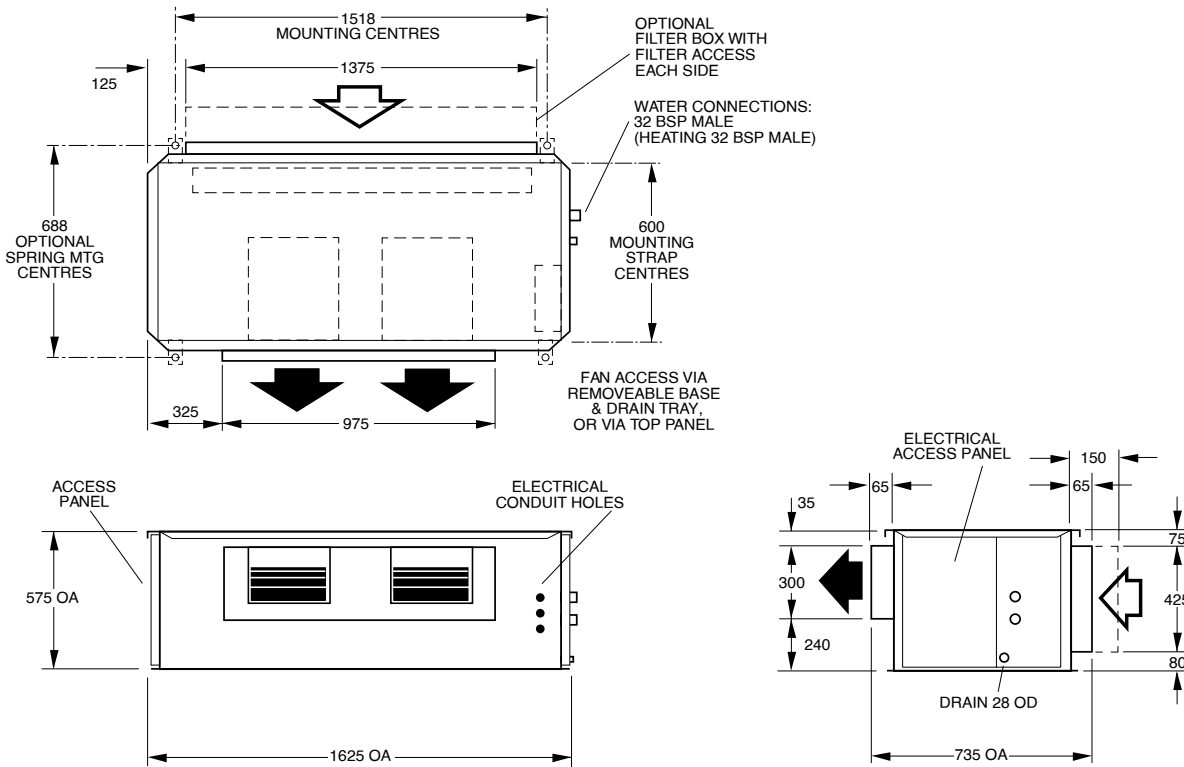

Sound Levels

Sound levels are specified as in-situ conditions. For more information and adjustment factors for your specific installation please find supplementary booklets under the relevant units on our website www.temperzone.com

Fan Speed	Sound Power Levels (SWL) (dB)						
	dB(A)	Octave Band Centre Frequency (Hz)					
		125	250	500	1K	2K	4K
Low	53	58	56	52	45	39	35
Med	58	63	61	57	49	44	41
High	65	69	68	64	56	51	49

IMD 550

				Low Air flow			Medium Air flow			Nominal Air flow		
4 row chilled water coil				1300 L/s			1800 L/s			2350 L/s		
Air on DB/WB	W. flow L/s	P.D. kPa	Cooling kW	Entering water temp			Entering water temp			Entering water temp		
				6	7	8	6	7	8	6	7	8
23/17	2.0	9.5	total	29.5	27.1	24.6	35.2	32.5	29.3	40.5	37.2	33.8
			sensible	20.4	19.3	18.3	25.5	24.3	23.1	30.5	29.1	27.7
	3.0	20.6	total	31.7	29.3	26.6	39.3	36.1	32.8	46.1	42.3	38.5
			sensible	21.4	20.3	19.2	27.3	25.9	24.5	32.9	31.2	29.6
	4.0	32.8	total	33.2	30.5	27.8	41.6	38.2	34.7	49.5	45.2	41.4
			sensible	22.1	20.9	19.7	28.3	26.8	25.3	34.3	32.5	30.8
27/19	2.0	9.5	total	36.2	33.7	31.2	43.5	40.5	37.4	49.5	46.1	43.0
			sensible	25.2	24.2	23.1	31.7	30.5	29.2	37.8	36.4	35.2
	3.0	20.6	total	39.2	36.6	33.9	48.2	45.0	41.6	56.7	52.8	48.8
			sensible	26.6	25.4	24.3	33.7	32.3	31.0	40.7	39.1	37.5
	4.0	32.8	total	40.8	38.1	35.3	51.1	47.8	44.1	60.6	56.2	52.3
			sensible	27.3	26.1	24.9	35.0	33.5	32.0	42.3	40.5	38.9
31/21	2.0	9.5	total	43.3	40.9	38.3	52.0	49.0	45.9	59.5	56.0	52.1
			sensible	30.0	28.9	27.9	37.6	36.5	35.3	45.1	43.7	42.3
	3.0	20.6	total	47.1	44.4	41.7	57.9	54.4	51.1	67.7	63.6	59.6
			sensible	31.6	30.4	29.2	40.1	38.7	37.3	48.2	46.7	45.1
	4.0	32.8	total	49.1	46.3	43.5	61.6	58.1	54.5	73.1	68.6	64.5
			sensible	32.5	31.2	30.0	41.6	40.1	38.7	50.4	48.6	47.0
35/24	2.0	9.5	total	55.1	52.6	49.9	65.5	62.3	59.0	74.1	70.4	66.7
			sensible	33.9	32.8	31.8	42.1	40.9	39.8	50.0	48.7	47.5
	3.0	20.6	total	60.0	57.2	54.3	73.6	70.1	66.5	85.3	81.2	76.9
			sensible	35.8	34.7	33.5	45.2	43.8	42.5	54.1	52.5	51.0
	4.0	32.8	total	62.7	60.0	57.0	78.5	74.7	70.9	92.5	88.0	83.5
			sensible	37.0	35.9	34.6	47.1	45.7	44.2	56.8	55.1	53.4
1 row hot water coil												
Air on DB	W. flow L/s	P.D. kPa	Heating kW	Entering water temp			Entering water temp			Entering water temp		
				50	65	80	50	65	80	50	65	80
7	0.4	4.5	heat	26.2	34.1	44.5	30.1	40.6	51.1	33.4	45.1	56.8
	0.8	15.4	heat	30.0	39.0	50.9	35.8	48.3	60.8	40.7	54.9	69.1
	1.2	31.5	heat	32.0	41.7	54.3	38.7	52.2	65.7	44.8	60.4	76.1
15	0.4	4.5	heat	21.2	30.4	39.4	24.4	34.9	45.4	27.2	38.8	50.4
	0.8	15.4	heat	24.3	34.6	45.1	29.0	41.4	53.9	33.0	47.1	61.3
	1.2	31.5	heat	25.9	37.0	48.1	31.5	45.0	58.5	36.3	51.9	67.4
21	0.4	4.5	heat	17.5	26.6	35.7	20.2	30.6	41.1	22.5	34.0	45.6
	0.8	15.4	heat	20.0	30.4	40.7	24.0	36.3	48.7	27.2	41.3	55.4
	1.2	31.5	heat	21.4	32.4	43.5	26.0	39.4	52.8	30.0	45.4	60.9

Performance Data

IMD 550

Air Handling

Notes:

1. Air flows given are for a unit with no filter installed.
2. In a free blown application, beware of exceeding indoor fan motor's full load amp limit.
3. Airflows are for dry coil. Reduce airflow by 10% in high moisture removal conditions. Refer to page 70 for filter pressure drop.

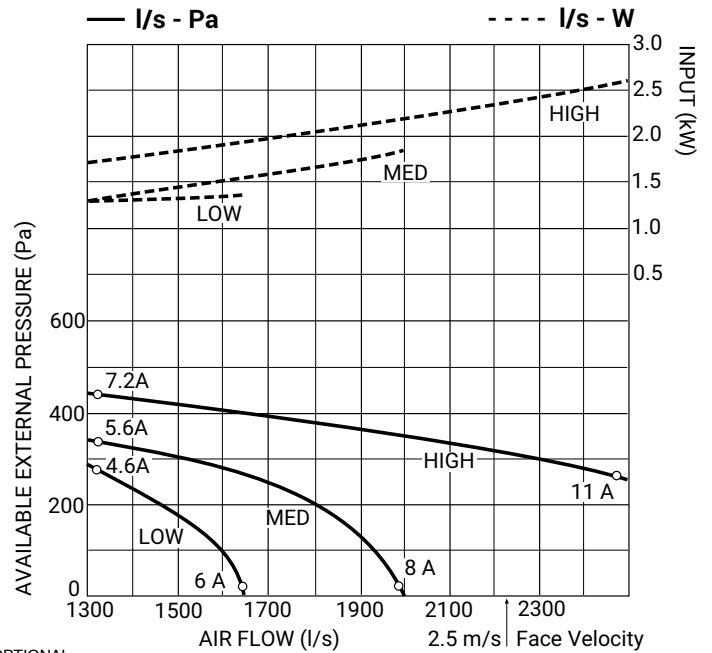

Dimensions

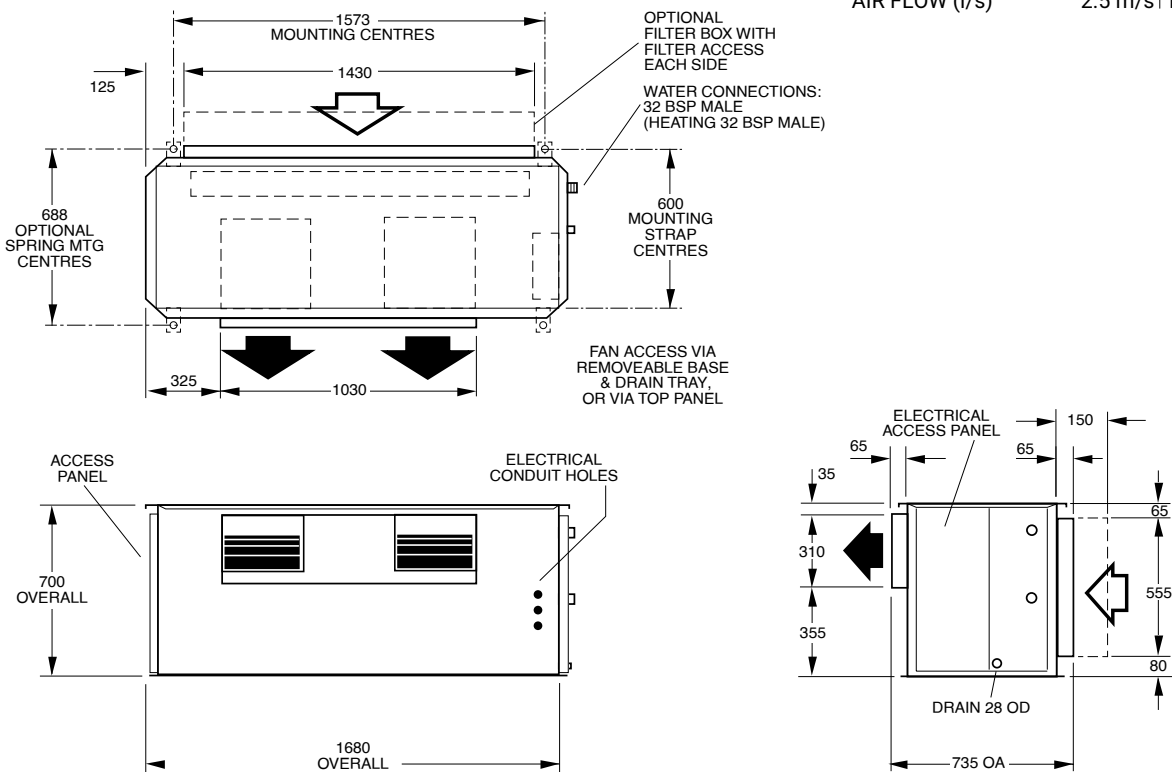

Sound Levels

Sound levels are specified as in-situ conditions. For more information and adjustment factors for your specific installation please find supplementary booklets under the relevant units on our website www.temperzone.com

Fan Speed	Sound Power Levels (SWL) (dB)						
	dB(A)	Octave Band Centre Frequency (Hz)					
		125	250	500	1K	2K	4K
Low	57	61	61	57	49	41	39
Med	61	65	65	61	53	46	44
High	66	69	70	66	58	51	49

Premium Range (Compact FCU)

IMD-Y

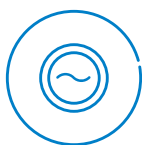

High Efficiency EC Motor



Electric Heating



Opposite Hand



Premium Range (IMD-Y) Specifications



Model	IMD 95Y	IMD 135Y	IMD 170Y	IMD 210	IMD 280Y	IMD 420Y	IMD 550Y
Nominal Air Flow (l/s) *	450	600	750	900	1250	1800	2350
Fan Type	Forward curved centrifugal double inlet double width						
No. of Fan Scrolls	1	1	1	2	2	2	2
Motor Type	Electronically Commutated (EC) DC direct drive						
Power Source **	1 Phase 230 Volt AC 50 Hz						
No. of Motors	1	1	1	1	1	2	2
Motor Rating (W)	600	900	1250	1250	1250	1250 (x2)	1250 (x2)
Full Load Amps (A) **	3.3	4.9	6.8	6.8	6.8	9 x 2 (18)	9 x 2 (18)
Optional Electric Heating (kW) ***	4	6	6	9	9	12	18
Electric Heat Current (A/ph)	17.6/1ph	8.8/3ph	8.8/3ph	13.2/3ph	13.2/3ph	17.6/3ph	26.4/3ph
Heat Exchanger Type	Epoxy aluminium corrugated plate fins to expanded rifled copper tube						
Cooling/Heating Medium	Chilled Water or Hot Water						
Finish	Zinc galvanised steel						
Test Pressure	2100 kPa						
Connection Sizes Cooling Coil (mm)	Ø 25 (1" BSP)	Ø 25 (1" BSP)	Ø 25 (1" BSP)	Ø 25 (1" BSP)	Ø 32 (1¼" BSP)	Ø 32 (1¼" BSP)	Ø 32 (1¼" BSP)
Connection Sizes Heating Coil (mm)	Ø 15 (½" BSP)	Ø 15 (½" BSP)	Ø 15 (½" BSP)	Ø 15 (½" BSP)	Ø 25 (1" BSP)	Ø 32 (1¼" BSP)	Ø 32 (1¼" BSP)
Optional Air Filter Type	G2 / EU2 Washable						
No. of optional Air Filters	1	1	1	1	2	2	2
Optional Air Filter Size (mm)	593 x 275 x 13	767 x 275 x 13	914 x 275 x 13	1064 x 275 x 13	593 x 345 x 13	685 x 415 x 13	712 x 542 x 13
Weight (4/1) Inc. Water (kg)	54	61	65	76	99	158	183
Nett Dry Weight (kg)	49	55	58	68	88	145	166
Shipping Weight (kg)	55	61	65	76	96	170	196

* with no filters fitted and with a dry coil surface

** Voltage fluctuation limits 200-252V fan motor only excluding electric heat

*** Optional Electric Heating - models IMD135 through IMD550 require a 3 phase AC power supply, 342-436V 50Hz

Cooling and Heating Coil options:

4 Row Cooling only

4 Row Cooling + 1 Row Heating

4 Row Cooling plus Electric Heating

IMD 95Y

				Low Air flow			Medium Air flow			Nominal Air flow		
4 row chilled water coil				250 L/s			350 L/s			450 L/s		
Air on DB/WB	W. flow L/s	P.D. kPa	Cooling kW	Entering water temp			Entering water temp			Entering water temp		
				6	7	8	6	7	8	6	7	8
23/17	0.3	7.0	total	5.4	5.0	4.5	6.4	5.9	5.4	7.2	6.7	6.1
			sensible	3.8	3.6	3.4	4.8	4.6	4.3	5.6	5.4	5.2
	0.5	17.6	total	6.0	5.5	5.0	7.4	6.8	6.1	8.5	7.9	7.1
			sensible	4.1	3.9	3.7	5.2	5.0	4.7	6.2	5.9	5.6
	0.7	32.4	total	6.4	5.8	5.3	8.0	7.3	6.7	9.3	8.6	7.8
			sensible	4.3	4.0	3.8	5.5	5.2	4.9	6.5	6.2	5.9
27/19	0.3	7.0	total	6.6	6.2	5.7	7.9	7.4	6.8	8.8	8.2	7.6
			sensible	4.7	4.5	4.3	5.9	5.7	5.5	7.0	6.8	6.6
	0.5	17.6	total	7.4	6.9	6.4	9.1	8.5	7.9	10.6	9.8	9.0
			sensible	5.1	4.8	4.6	6.5	6.2	5.9	7.7	7.4	7.1
	0.7	32.4	total	7.8	7.3	6.8	9.8	9.2	8.5	11.5	10.7	10.0
			sensible	5.2	5.0	4.8	6.8	6.5	6.2	8.1	7.8	7.5
31/21	0.3	7.0	total	8.0	7.5	7.1	9.4	8.9	8.3	10.5	9.9	8.3
			sensible	5.6	5.4	5.3	7.1	6.9	6.6	8.3	8.1	7.9
	0.5	17.6	total	8.9	8.4	7.9	10.9	10.3	9.6	12.5	11.8	11.1
			sensible	6.0	5.8	5.6	7.7	7.4	7.1	9.1	8.8	8.6
	0.7	32.4	total	9.4	8.9	8.3	11.8	11.1	10.4	13.8	13.0	12.2
			sensible	6.2	6.0	5.8	8.0	7.8	7.5	9.6	9.3	9.0
35/24	0.3	7.0	total	10.1	9.6	9.1	11.8	11.2	10.6	13.1	12.4	11.7
			sensible	6.3	6.1	5.9	7.9	7.7	7.5	9.2	9.0	8.8
	0.5	17.6	total	11.3	10.8	10.2	13.9	13.2	12.5	15.8	15.0	14.2
			sensible	6.8	6.6	6.4	8.6	8.4	8.1	10.2	9.9	9.6
	0.7	32.4	total	12.0	11.5	10.9	15.0	14.3	13.6	17.5	16.6	15.7
			sensible	7.1	6.9	6.6	9.1	8.8	8.5	10.8	10.5	10.2
1 row hot water coil												
Air on DB	W. flow L/s	P.D. kPa	Heating kW	Entering water temp			Entering water temp			Entering water temp		
				50	65	80	50	65	80	50	65	80
7	0.04	1.6	heat	4.2	5.7	7.2	4.7	6.4	7.9	5.0	6.8	8.5
	0.12	10.4	heat	5.6	7.5	9.5	6.6	9.0	11.3	7.5	10.0	12.7
	0.2	25.7	heat	6.1	8.2	10.4	7.4	10.0	12.6	8.4	11.4	14.3
15	0.04	1.6	heat	3.4	4.9	6.4	3.8	5.4	7.1	4.1	5.8	7.6
	0.12	10.4	heat	4.5	6.5	8.4	5.4	7.7	10.0	6.0	8.6	11.2
	0.2	25.7	heat	4.9	7.1	9.2	6.0	8.6	11.1	6.8	9.8	12.7
21	0.04	1.6	heat	2.8	4.3	5.8	3.2	4.8	6.4	3.4	5.1	6.9
	0.12	10.4	heat	3.7	5.7	7.6	4.4	6.7	9.0	5.0	7.6	10.1
	0.2	25.7	heat	4.1	6.2	8.3	5.0	7.5	10.1	5.7	8.6	11.5

Performance Data

IMD 95Y

Air Handling

Notes:

1. Air flows given are for a unit with no filter installed.
2. In a free blown application, beware of exceeding indoor fan motor's full load amp limit.
3. Airflows are for dry coil. Reduce airflow by 10% in high moisture removal conditions. Refer to page 70 for filter pressure drop.

Dimensions

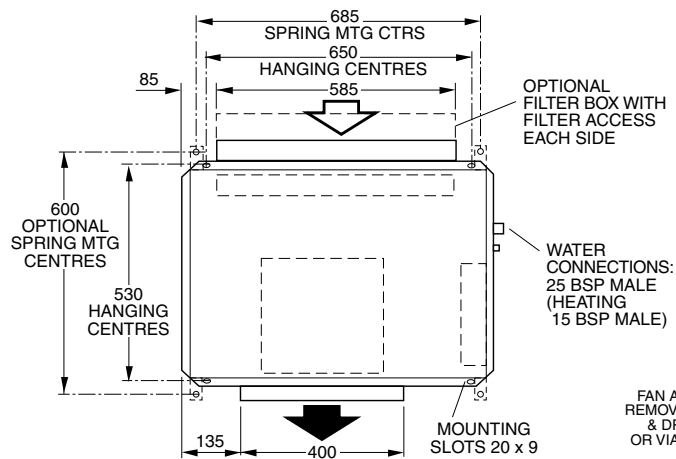

FAN ACCESS VIA REMOVEABLE BASE & DRAIN TRAY, OR VIA TOP PANEL

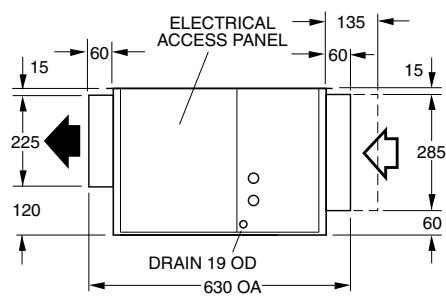
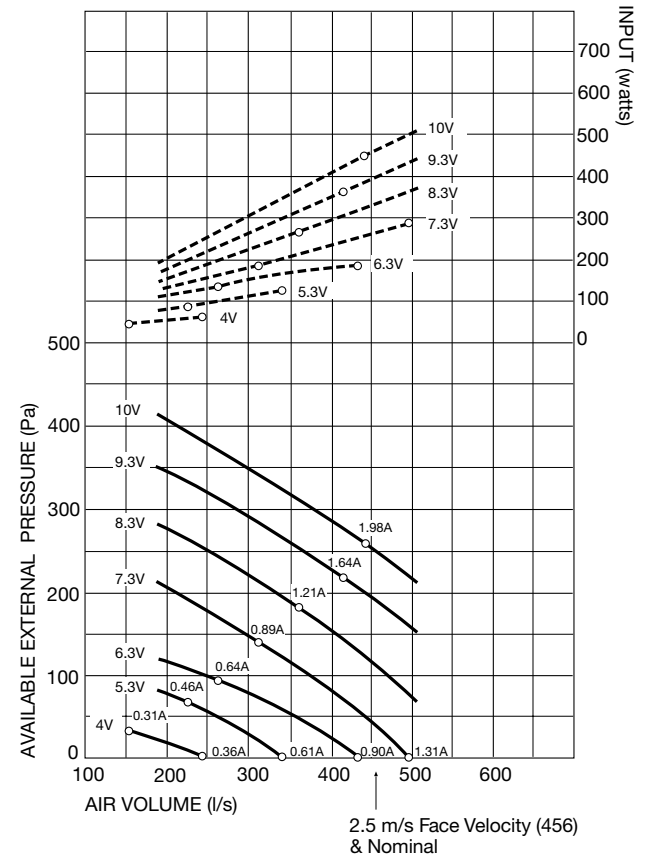
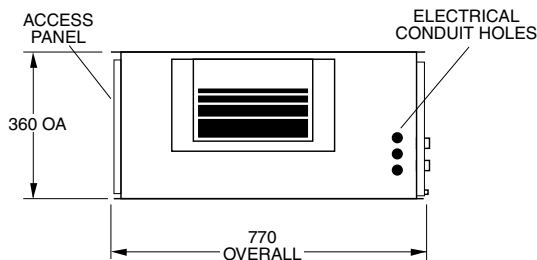

Sound Levels

Sound levels are specified as in-situ conditions. For more information and adjustment factors for your specific installation please find supplementary booklets under the relevant units on our website www.temperzone.com

Fan Speed	Vdc	RPM	Sound Power Levels (SWL) (dB)						
			dB(A)	Octave Band Centre Frequency (Hz)					
				125	250	500	1K	2K	4K
Low	7.3	1100	48	56	51	45	40	34	33
Med	8.3	1250	52	59	57	49	45	39	39
High	9.3	1400	58	66	63	53	49	45	44

IMD 135Y

				Low Air flow			Medium Air flow			Nominal Air flow		
4 row chilled water coil				300 L/s			450 L/s			600 L/s		
Air on DB/WB	W. flow L/s	P.D. kPa	Cooling kW	Entering water temp			Entering water temp			Entering water temp		
				6	7	8	6	7	8	6	7	8
23/17	0.2	4.0	total	5.8	5.3	4.9	6.8	6.3	5.7	7.5	6.8	6.3
			sensible	4.3	4.1	3.9	5.6	5.3	5.1	6.6	6.4	6.2
	0.4	13.9	total	7.0	6.4	5.8	8.7	8.0	7.3	10.1	9.2	8.4
			sensible	4.8	4.6	4.3	6.4	6.0	5.7	7.7	7.3	7.0
	0.6	28.9	total	7.5	6.9	6.3	9.8	9.0	8.2	11.5	10.6	9.6
			sensible	5.1	4.8	4.5	6.8	6.5	6.1	8.3	7.9	7.5
27/19	0.2	4.0	total	7.1	6.6	6.2	8.3	7.7	7.2	9.0	8.4	7.9
			sensible	5.3	5.1	4.9	6.9	6.7	6.5	8.3	8.1	7.9
	0.4	13.9	total	8.6	8.0	7.4	10.7	10.0	9.2	12.3	11.4	10.6
			sensible	5.9	5.7	5.5	7.9	7.6	7.3	9.5	9.2	8.9
	0.6	28.9	total	9.3	8.6	8.0	12.0	11.2	10.4	14.1	13.2	12.2
			sensible	6.3	6.0	5.7	8.4	8.1	7.7	10.3	9.9	9.5
31/21	0.2	4.0	total	8.5	8.0	7.5	9.8	9.3	8.7	10.7	10.1	9.5
			sensible	6.3	6.1	5.9	8.2	8.0	7.8	9.9	9.7	9.5
	0.4	13.9	total	10.3	9.7	9.1	12.8	12.1	11.3	14.7	13.8	12.9
			sensible	7.1	6.8	6.6	9.4	9.1	8.8	11.4	11.0	10.7
	0.6	28.9	total	11.1	10.5	9.8	14.4	13.5	12.7	16.9	15.9	14.9
			sensible	7.4	7.1	6.9	10.0	9.7	9.3	12.2	11.8	11.4
35/24	0.2	4.0	total	10.6	10.1	9.6	12.1	11.6	11.0	13.1	12.5	11.9
			sensible	7.0	6.9	6.7	9.1	8.9	8.7	10.9	10.7	10.5
	0.4	13.9	total	13.0	12.5	11.8	16.1	15.3	14.5	18.2	17.3	16.4
			sensible	8.0	7.7	7.5	10.5	10.2	9.9	12.5	12.2	11.9
	0.6	28.9	total	14.2	13.6	12.9	18.3	17.4	16.5	21.3	20.2	19.2
			sensible	8.5	8.2	7.9	11.3	10.9	10.6	13.6	13.3	12.9
1 row hot water coil												
Air on DB	W. flow L/s	P.D. kPa	Heating kW	Entering water temp			Entering water temp			Entering water temp		
				50	65	80	50	65	80	50	65	80
7	0.04	2.0	heat	4.9	6.6	8.2	5.4	7.3	9.1	5.8	7.8	9.8
	0.12	13.5	heat	6.7	9.1	11.4	8.2	11.1	14.0	9.3	12.5	15.8
	0.2	33.3	heat	7.4	10.0	12.6	9.3	12.6	15.9	10.8	14.5	18.3
15	0.04	2.0	heat	4.0	5.7	7.3	4.4	6.3	8.2	4.7	6.7	8.7
	0.12	13.5	heat	5.5	7.8	10.1	6.7	9.5	12.4	7.6	10.8	14.0
	0.2	33.3	heat	6.0	8.6	11.2	7.54	10.8	14.0	8.7	12.5	16.2
21	0.04	2.0	heat	3.3	5.0	6.6	3.6	5.5	7.4	3.9	5.9	7.8
	0.12	13.5	heat	4.5	6.8	9.2	5.5	8.4	11.2	6.2	9.5	12.7
	0.2	33.3	heat	5.0	7.5	10.1	6.2	9.4	12.7	7.2	10.9	14.7

Performance Data

IMD 135Y

Air Handling

Notes:

1. Air flows given are for a unit with no filter installed.
2. In a free blown application, beware of exceeding indoor fan motor's full load amp limit.
3. Airflows are for dry coil. Reduce airflow by 10% in high moisture removal conditions. Refer to page 70 for filter pressure drop.

Dimensions

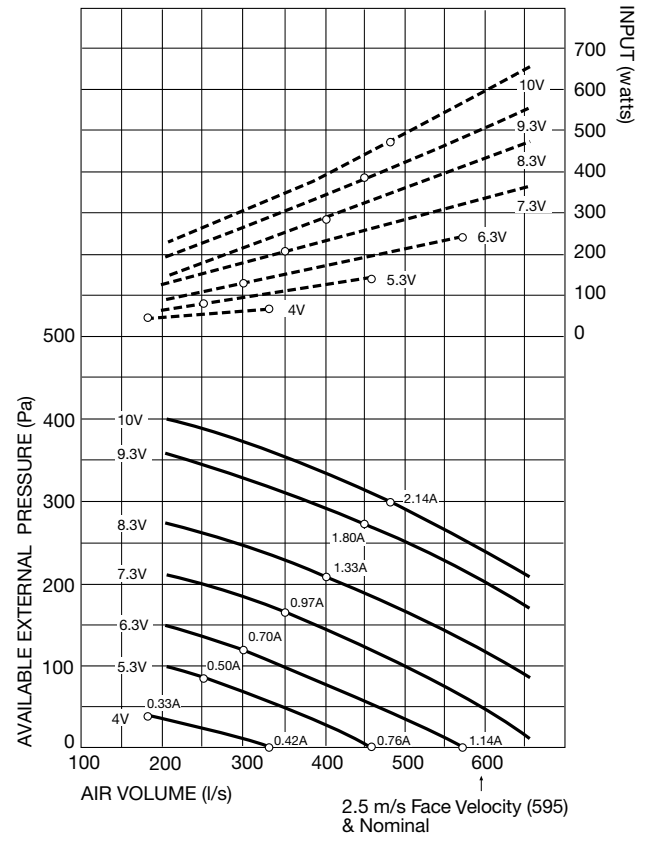
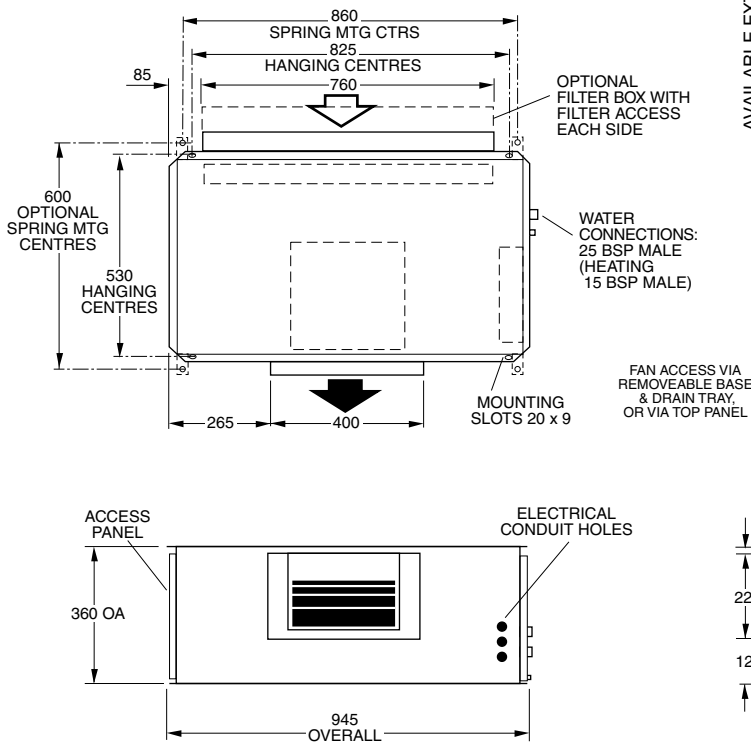

Sound Levels

Sound levels are specified as in-situ conditions. For more information and adjustment factors for your specific installation please find supplementary booklets under the relevant units on our website www.temperzone.com

Fan Speed	Vdc	RPM	Sound Power Levels (SWL) (dB)						
			dB(A)	Octave Band Centre Frequency (Hz)					
				125	250	500	1K	2K	4K
Low	7.3	1100	44	53	49	39	34	30	29
Med	8.3	1250	47	56	52	44	38	34	33
High	9.3	1400	52	59	57	49	43	39	39

IMD 170Y

				Low Air flow			Medium Air flow			Nominal Air flow		
4 row chilled water coil				350 L/s			550 L/s			750 L/s		
Air on DB/WB	W. flow L/s	P.D. kPa	Cooling kW	Entering water temp			Entering water temp			Entering water temp		
				6	7	8	6	7	8	6	7	8
23/17	0.3	9.3	total	7.5	6.9	6.3	9.2	8.5	7.7	10.3	9.5	8.8
			sensible	5.3	5.1	4.8	7.2	6.8	6.5	8.7	8.4	8.0
	0.45	19.4	total	8.3	7.6	6.9	10.6	9.7	8.9	12.3	11.3	10.3
			sensible	5.7	5.4	5.1	7.7	7.4	7.0	9.5	9.1	8.6
	0.6	33.4	total	8.8	8.0	7.3	11.6	10.6	9.7	13.8	12.6	11.5
			sensible	5.9	5.6	5.2	8.2	7.8	7.4	10.1	9.6	9.2
27/19	0.3	9.3	total	9.2	8.6	8.0	11.2	10.5	9.7	12.6	11.8	11.0
			sensible	6.6	6.3	6.1	8.9	8.6	8.3	10.8	10.5	10.2
	0.45	19.4	total	10.2	9.5	8.8	13.1	12.2	11.3	15.1	14.0	13.0
			sensible	7.0	6.7	6.4	9.6	9.3	8.9	11.8	11.4	11.0
	0.6	33.4	total	10.8	10.0	9.3	14.2	13.3	12.3	16.9	15.7	14.6
			sensible	7.3	7.0	6.6	10.1	9.7	9.3	12.5	12.0	11.6
31/21	0.3	9.3	total	11.0	10.4	9.8	13.4	12.7	11.9	15.0	14.1	13.3
			sensible	7.8	7.6	7.3	10.6	10.3	10.0	12.9	12.6	12.3
	0.45	19.4	total	12.2	11.5	10.8	15.6	14.7	13.8	18.0	16.9	15.9
			sensible	8.3	8.0	7.8	11.4	11.1	10.7	14.0	13.6	13.2
	0.6	33.4	total	12.9	12.2	11.4	17.0	16.0	15.0	20.2	18.9	17.8
			sensible	8.6	8.3	8.0	12.0	11.6	11.2	14.8	14.4	13.9
35/24	0.3	9.3	total	13.9	13.2	12.5	16.7	15.8	15.0	18.4	17.5	16.6
			sensible	8.8	8.5	8.3	11.7	11.4	11.1	14.2	13.9	13.6
	0.45	19.4	total	15.5	14.8	14.0	19.6	18.6	17.7	22.4	21.3	20.2
			sensible	9.4	9.1	8.8	12.7	12.4	12.1	15.5	15.1	14.8
	0.6	33.4	total	16.5	15.7	15.0	21.6	20.6	19.5	25.2	23.9	22.7
			sensible	9.8	9.5	9.2	13.5	13.1	12.7	16.5	16.0	15.6

1 row hot water coil				Entering water temp			Entering water temp			Entering water temp		
Air on DB	W. flow L/s	P.D. kPa	Heating kW	50	65	80	50	65	80	50	65	80
				7	0.06	4.5	heat	6.4	8.6	10.8	7.3	9.9
0.12	13.4	heat	7.8		10.5	13.2	9.5	12.9	16.2	10.8	14.6	18.3
0.18	31.4	heat	8.5		11.4	14.6	10.7	14.4	18.2	12.4	16.7	21.0
15	0.06	4.5	heat	5.2	7.4	9.6	5.9	8.5	11.0	6.4	9.2	11.9
	0.12	15.4	heat	6.3	9.0	11.7	7.7	11.1	14.4	8.8	12.5	16.3
	0.18	31.4	heat	7.0	9.8	12.7	8.7	12.4	16.1	10.0	14.4	18.7
21	0.06	4.5	heat	4.3	6.4	8.7	4.9	7.4	10.0	5.3	8.1	10.9
	0.12	15.4	heat	5.2	7.9	10.5	6.4	9.7	13.0	7.3	11.0	14.8
	0.18	31.4	heat	5.6	8.6	11.5	7.2	10.9	14.6	8.3	12.6	16.9

Performance Data

IMD 170Y

Air Handling

Notes:

1. Air flows given are for a unit with no filter installed.
2. In a free blown application, beware of exceeding indoor fan motor's full load amp limit.
3. Airflows are for dry coil. Reduce airflow by 10% in high moisture removal conditions. Refer to page 70 for filter pressure drop.

Dimensions

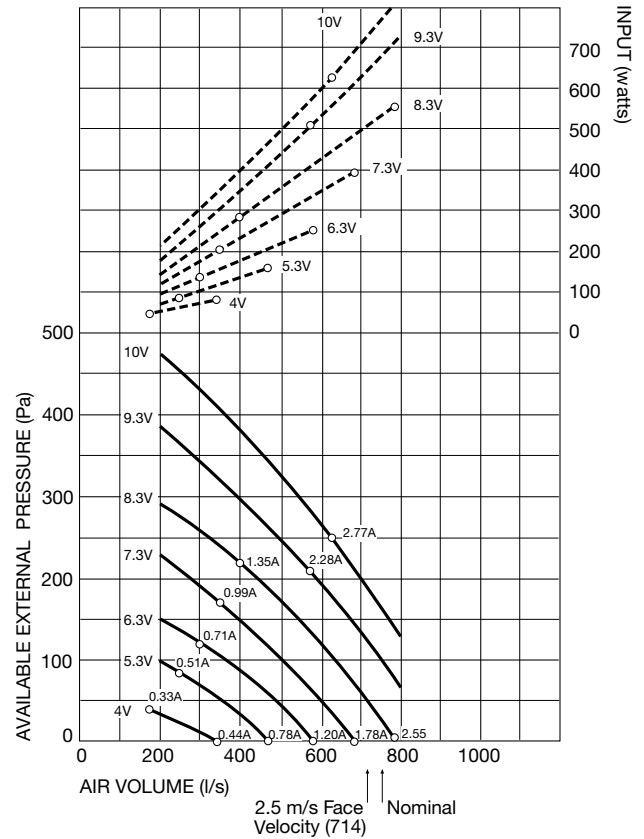
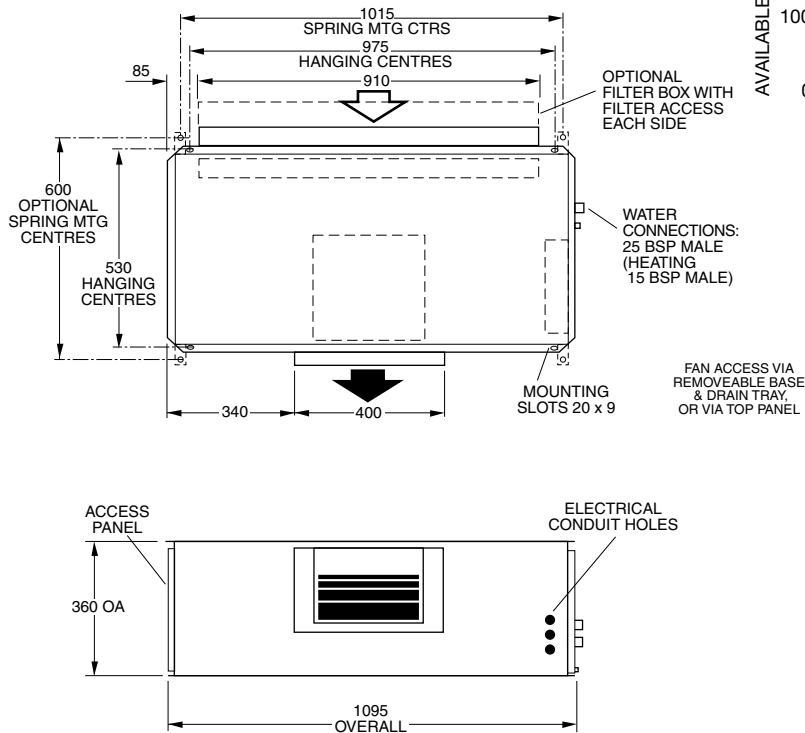

Sound Levels

Sound levels are specified as in-situ conditions. For more information and adjustment factors for your specific installation please find supplementary booklets under the relevant units on our website www.temperzone.com

Fan Speed	Vdc	RPM	Sound Power Levels (SWL) (dB)						
			dB(A)	Octave Band Centre Frequency (Hz)					
				125	250	500	1K	2K	4K
Low	6.3	950	44	47	45	43	37	31	30
Med	8.3	1250	53	55	55	52	45	40	40
High	10	1500	62	63	65	59	57	50	50

IMD 210Y

				Low Air flow			Medium Air flow			Nominal Air flow		
4 row chilled water coil				400 L/s			650 L/s			900 L/s		
Air on DB/WB	W. flow L/s	P.D. kPa	Cooling kW	Entering water temp			Entering water temp			Entering water temp		
				6	7	8	6	7	8	6	7	8
23/17	0.4	9.5	total	8.9	8.2	7.5	11.3	10.3	9.4	12.8	11.8	10.7
			sensible	6.2	5.9	5.6	8.6	8.2	7.8	10.6	10.1	9.7
	0.6	19.6	total	9.7	8.9	8.1	12.9	11.8	10.8	15.2	13.9	12.7
			sensible	6.6	6.2	5.9	9.3	8.8	8.4	11.5	11.0	10.5
	0.8	33.5	total	10.2	9.4	8.6	14.0	12.8	11.7	16.8	15.4	14.0
			sensible	6.8	6.5	6.1	9.8	9.3	8.8	12.2	11.6	11.0
27/19	0.4	9.5	total	10.9	10.2	9.4	13.8	12.9	11.9	15.6	14.7	13.6
			sensible	7.7	7.4	7.1	10.7	10.3	9.9	13.1	12.8	12.4
	0.6	19.6	total	11.9	11.1	10.4	15.8	14.8	13.7	18.6	17.3	16.1
			sensible	8.2	7.8	7.5	11.5	11.1	10.6	14.3	13.8	13.3
	0.8	33.5	total	12.6	10.7	10.9	17.2	16.0	14.8	20.6	19.2	17.7
			sensible	8.5	8.1	7.7	12.1	11.6	11.1	15.1	14.5	14.0
31/21	0.4	9.5	total	13.1	12.3	11.6	16.4	15.5	14.5	18.6	17.6	16.4
			sensible	9.2	8.9	8.5	12.7	12.3	12.0	15.7	15.3	14.9
	0.6	19.6	total	14.3	13.6	12.7	19.0	17.9	16.7	22.2	20.8	19.7
			sensible	9.7	9.4	9.0	13.7	13.3	12.8	17.0	16.5	16.1
	0.8	33.5	total	15.1	14.3	13.4	20.6	19.4	18.2	24.6	23.1	21.8
			sensible	10.0	9.7	9.3	14.3	13.9	13.4	17.9	17.4	16.9
35/24	0.4	9.5	total	16.6	15.8	14.9	20.5	19.5	18.5	22.9	21.8	20.5
			sensible	10.3	10.0	9.7	14.1	13.7	13.4	17.2	16.9	16.6
	0.6	19.6	total	18.3	17.4	16.5	23.8	22.7	21.5	27.6	26.3	24.9
			sensible	11.0	10.7	10.3	15.3	14.9	14.4	18.8	18.4	17.9
	0.8	33.5	total	19.3	18.4	17.5	26.1	24.9	23.6	30.9	29.4	27.8
			sensible	11.4	11.0	10.7	16.2	15.7	15.2	20.0	19.5	18.9
1 row hot water coil												
Air on DB	W. flow L/s	P.D. kPa	Heating kW	Entering water temp			Entering water temp			Entering water temp		
				50	65	80	50	65	80	50	65	80
7	0.08	8.4	heat	7.8	10.5	13.2	9.2	12.4	15.6	10.1	13.6	17.1
	0.12	17.3	heat	8.7	11.7	14.7	10.8	14.5	18.3	12.2	16.4	20.7
	0.16	28.8	heat	9.3	12.6	15.8	11.8	16.0	20.1	13.6	18.3	23.0
15	0.08	8.4	heat	6.3	9.0	11.7	7.4	10.6	13.9	8.2	11.7	15.2
	0.12	17.3	heat	7.1	10.1	13.1	8.7	12.5	16.2	9.9	14.1	18.3
	0.16	28.8	heat	7.7	10.8	14.0	9.6	13.7	17.8	11.0	15.7	20.4
21	0.08	8.4	heat	5.2	7.9	10.6	6.2	9.4	12.5	6.8	10.3	13.8
	0.12	17.3	heat	5.8	8.8	11.8	7.2	11.0	14.7	8.2	12.4	16.6
	0.16	28.8	heat	6.4	9.5	12.7	8.2	12.0	16.1	9.1	13.8	18.5

Performance Data

IMD 210Y

Air Handling

Notes:

1. Air flows given are for a unit with no filter installed.
2. In a free blown application, beware of exceeding indoor fan motor's full load amp limit.
3. Airflows are for dry coil. Reduce airflow by 10% in high moisture removal conditions. Refer to page 70 for filter pressure drop.

Dimensions

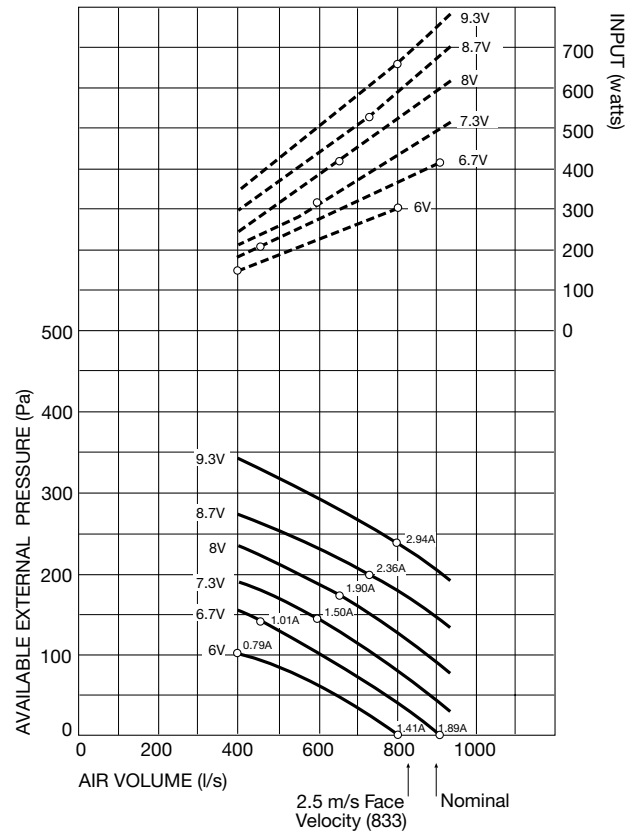
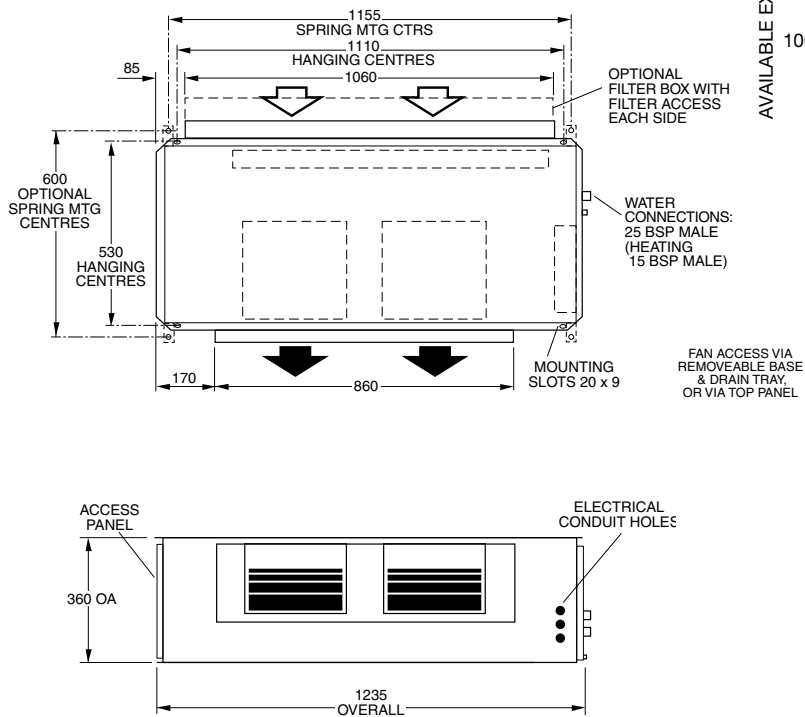

Sound Levels

Sound levels are specified as in-situ conditions. For more information and adjustment factors for your specific installation please find supplementary booklets under the relevant units on our website www.temperzone.com

Fan Speed	Vdc	RPM	Sound Power Levels (SWL) (dB)						
			dB(A)	Octave Band Centre Frequency (Hz)					
				125	250	500	1K	2K	4K
Low	6.7	1000	46	48	47	46	39	33	30
Med	8	1200	52	56	54	52	46	41	39
High	9.3	1400	60	62	61	57	56	49	48

IMD 280Y

				Low Air flow			Medium Air flow			Nominal Air flow		
4 row chilled water coil				600 L/s			900 L/s			1200 L/s		
Air on DB/WB	W. flow L/s	P.D. kPa	Cooling kW	Entering water temp			Entering water temp			Entering water temp		
				6	7	8	6	7	8	6	7	8
23/17	0.6	7.0	total	12.8	11.7	10.7	15.5	14.2	13.0	17.4	16.0	14.6
			sensible	9.1	8.6	8.2	11.9	11.3	10.8	14.2	13.7	13.1
	1.0	17.8	total	14.5	13.2	12.0	18.3	16.8	15.3	21.2	19.5	17.7
			sensible	9.8	9.3	8.7	13.0	12.4	11.7	15.8	15.0	14.3
	1.4	33.1	total	15.2	13.9	12.7	19.9	18.3	16.6	23.6	21.7	19.7
			sensible	10.2	9.6	9.1	13.7	13.0	12.3	16.8	16.0	15.2
27/19	0.6	7.0	total	15.7	14.6	13.5	19.0	17.7	16.4	21.2	19.8	18.4
			sensible	11.2	10.8	10.3	14.7	14.2	13.7	17.7	17.2	16.6
	1.0	17.8	total	17.7	16.5	15.3	22.4	20.9	19.3	26.0	24.2	22.4
			sensible	12.1	11.6	11.1	16.1	15.5	14.9	19.6	18.9	18.2
	1.4	33.1	total	18.7	17.4	16.2	24.4	22.8	21.1	29.0	27.0	25.0
			sensible	12.6	12.0	11.4	17.0	16.3	15.6	20.8	20.0	19.2
31/21	0.6	7.0	total	18.8	17.7	16.6	22.7	21.3	20.0	25.4	23.9	22.4
			sensible	13.4	12.9	12.5	17.5	17.0	16.5	21.1	20.6	20.0
	1.0	17.8	total	21.2	20.0	18.7	26.9	25.3	23.7	31.1	29.3	27.5
			sensible	14.4	13.9	13.3	19.2	18.5	17.9	23.3	22.6	21.9
	1.4	33.1	total	22.5	21.2	19.9	29.3	27.6	25.9	34.7	32.7	30.6
			sensible	14.9	14.4	13.8	20.2	19.5	18.8	24.7	23.9	23.1
35/24	0.6	7.0	total	23.7	22.5	21.4	28.3	26.9	25.5	31.4	29.8	28.3
			sensible	15.0	14.5	14.1	19.4	19.0	18.5	23.3	22.8	22.3
	1.0	17.8	total	26.9	25.7	24.3	33.9	32.2	30.6	38.9	37.0	35.0
			sensible	16.3	15.7	15.2	21.5	20.9	20.2	25.9	25.2	24.5
	1.4	33.1	total	28.7	27.4	26.1	37.2	35.6	33.7	43.8	41.7	39.5
			sensible	17.0	16.5	15.9	22.7	22.1	21.4	26.6	26.9	26.1
1 row hot water coil												
Air on DB	W. flow L/s	P.D. kPa	Heating kW	Entering water temp			Entering water temp			Entering water temp		
				50	65	80	50	65	80	50	65	80
7	0.2	2.8	heat	12.5	16.9	21.2	14.8	20.0	25.2	16.6	22.4	28.2
	0.4	9.6	heat	14.1	19.0	23.9	17.5	23.6	29.7	20.1	27.1	34.1
	0.6	20.2	heat	15.0	20.2	25.4	18.9	25.6	32.2	22.1	29.8	37.5
15	0.2	2.8	heat	9.9	15.1	18.5	11.8	16.9	22.0	13.3	18.9	24.6
	0.4	9.6	heat	12.2	17.0	20.8	13.9	19.9	25.9	16.0	22.9	29.8
	0.6	20.2	heat	13.0	18.1	22.1	15.1	21.5	28.0	17.6	25.2	32.7
21	0.2	2.8	heat	8.2	12.5	16.8	9.8	14.9	19.9	10.9	16.6	22.3
	0.4	9.6	heat	9.3	14.0	18.8	11.5	17.5	23.4	13.2	20.1	26.9
	0.6	20.2	heat	9.8	14.9	20.0	12.5	18.9	25.3	14.5	22.1	29.6

Performance Data

IMD 280Y

Air Handling

Notes:

1. Air flows given are for a unit with no filter installed.
2. In a free blown application, beware of exceeding indoor fan motor's full load amp limit.
3. Airflows are for dry coil. Reduce airflow by 10% in high moisture removal conditions. Refer to page 70 for filter pressure drop.

Dimensions

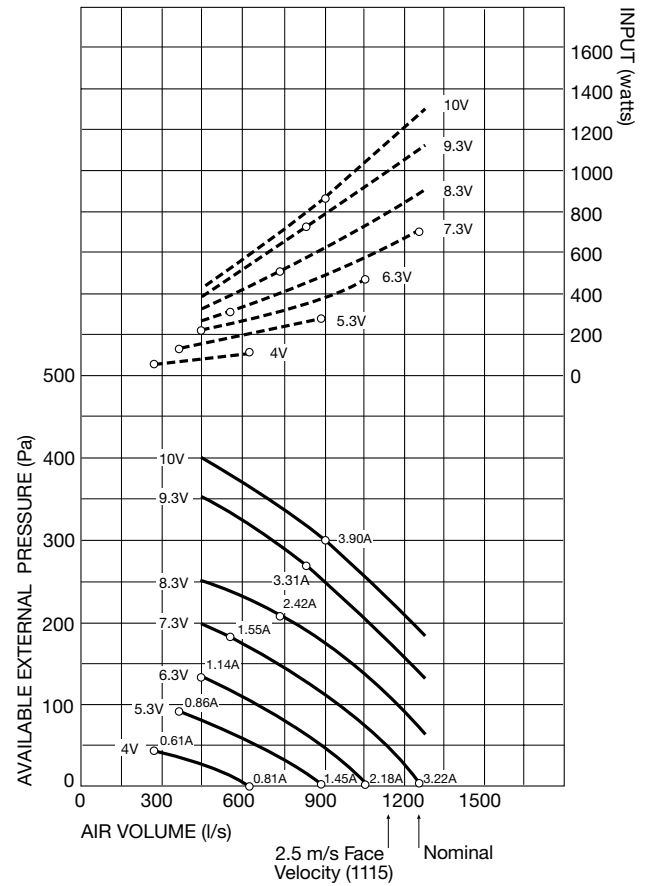
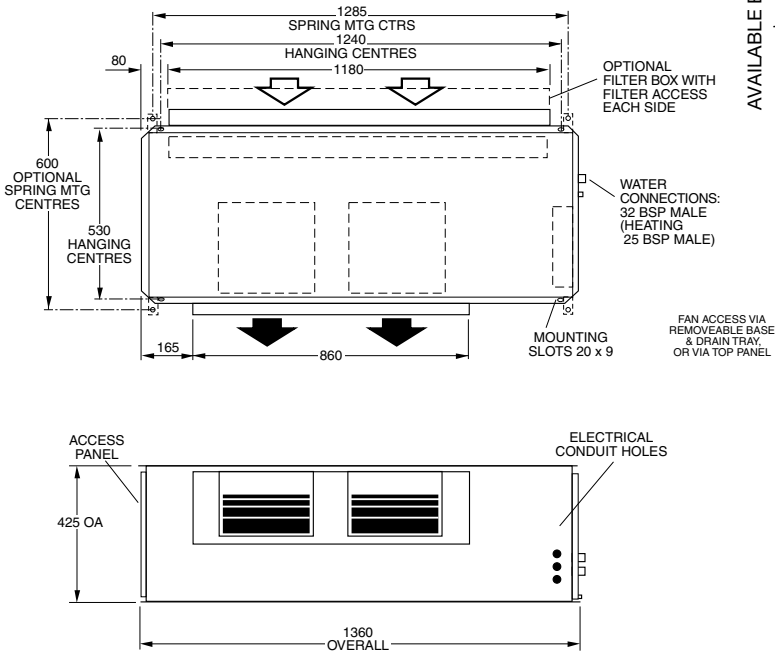

Sound Levels

Sound levels are specified as in-situ conditions. For more information and adjustment factors for your specific installation please find supplementary booklets under the relevant units on our website www.temperzone.com

Fan Speed	Vdc	RPM	Sound Power Levels (SWL) (dB)						
			dB(A)	Octave Band Centre Frequency (Hz)					
				125	250	500	1K	2K	4K
Low	6.3	950	45	49	48	44	38	34	31
Med	8.3	1250	55	58	58	53	49	44	41
High	10	1500	64	66	66	61	58	54	52

IMD 420Y

				Low Air flow			Medium Air flow			Nominal Air flow		
4 row chilled water coil				1000 L/s			1400 L/s			1800 L/s		
Air on DB/WB	W. flow L/s	P.D. kPa	Cooling kW	Entering water temp			Entering water temp			Entering water temp		
				6	7	8	6	7	8	6	7	8
23/17	1.0	3.9	total	20.4	18.8	17.1	23.9	21.9	19.9	26.4	24.4	22.2
			sensible	14.7	14.0	13.3	18.3	17.5	16.7	21.5	20.7	19.8
	2.0	13.9	total	23.8	21.9	19.9	29.2	26.8	24.4	33.6	31.1	28.2
			sensible	16.2	15.4	14.5	20.6	19.6	18.6	24.5	23.4	22.2
	3.0	29.8	total	25.3	23.3	21.2	32.0	29.3	26.7	37.4	34.5	31.2
			sensible	16.9	16.0	15.1	21.8	20.7	19.5	26.1	24.8	23.4
27/19	1.0	3.9	total	25.0	23.3	21.6	29.1	27.2	25.2	32.1	30.2	27.9
			sensible	18.2	17.5	16.8	22.8	22.0	21.2	26.7	26.0	25.1
	2.0	13.9	total	29.3	27.3	25.3	35.8	33.4	30.9	41.6	38.6	35.6
			sensible	20.0	19.2	18.3	25.5	24.5	23.5	30.5	29.3	28.1
	3.0	29.8	total	31.2	29.1	27.0	39.4	36.7	34.0	46.2	43.1	40.1
			sensible	20.9	20.0	19.1	27.0	25.9	24.7	32.4	31.1	29.9
31/21	1.0	3.9	total	29.9	28.2	26.5	34.8	32.8	30.7	38.6	36.0	34.0
			sensible	21.6	20.9	20.3	27.1	26.3	25.6	32.0	31.0	30.3
	2.0	13.9	total	35.1	33.1	31.0	43.0	40.5	38.0	49.5	46.4	43.7
			sensible	23.8	23.0	22.1	30.3	29.3	28.3	36.1	34.9	33.9
	3.0	29.8	total	37.5	35.3	33.2	47.3	44.6	41.8	55.3	52.3	49.2
			sensible	24.9	23.9	23.0	32.2	31.0	29.8	38.4	37.2	36.0
35/24	1.0	3.9	total	37.7	35.9	34.0	43.4	41.3	39.1	47.4	45.1	42.8
			sensible	24.2	23.5	22.9	30.0	29.3	28.6	35.1	34.4	33.6
	2.0	13.9	total	44.6	42.5	40.6	54.5	51.8	49.2	62.1	59.0	56.0
			sensible	27.0	26.1	25.3	34.1	33.1	32.1	40.2	39.1	38.0
	3.0	29.8	total	48.1	45.9	43.6	60.1	57.3	54.4	70.2	66.7	63.2
			sensible	28.4	27.5	26.5	36.3	35.2	34.0	43.2	41.9	40.7
1 row hot water coil												
Air on DB	W. flow L/s	P.D. kPa	Heating kW	Entering water temp			Entering water temp			Entering water temp		
				50	65	80	50	65	80	50	65	80
7	0.3	3.9	heat	20.0	27.0	34.0	23.1	31.1	39.2	25.4	34.3	43.2
	0.6	12.2	heat	22.9	30.9	38.9	27.5	37.1	46.7	31.0	41.8	52.6
	0.9	27.4	heat	24.5	33.0	41.5	29.8	40.3	50.7	34.1	46.0	57.9
15	0.3	3.9	heat	16.2	23.2	30.1	18.7	26.7	34.8	20.7	29.5	38.4
	0.6	12.2	heat	18.5	26.5	34.4	22.3	31.8	41.4	25.1	35.9	46.6
	0.9	27.4	heat	19.8	28.3	36.8	24.2	34.5	44.9	27.6	39.5	51.3
21	0.3	3.9	heat	13.4	20.3	27.3	15.5	23.5	31.5	17.0	25.9	34.7
	0.6	12.2	heat	15.3	23.2	31.1	18.4	27.9	37.4	20.7	31.5	42.2
	0.9	27.4	heat	16.3	24.8	33.2	19.9	30.2	40.5	22.8	34.6	46.4

Performance Data

IMD 420Y

Air Handling

Notes:

1. Air flows given are for a unit with no filter installed.
2. In a free blown application, beware of exceeding indoor fan motor's full load amp limit.
3. Airflows are for dry coil. Reduce airflow by 10% in high moisture removal conditions. Refer to page 70 for filter pressure drop.

Dimensions

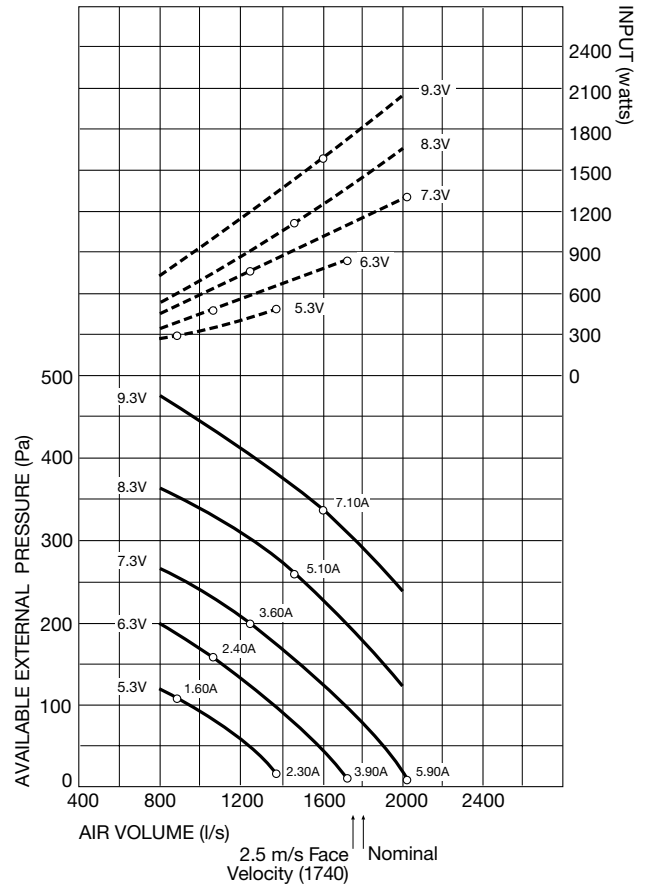
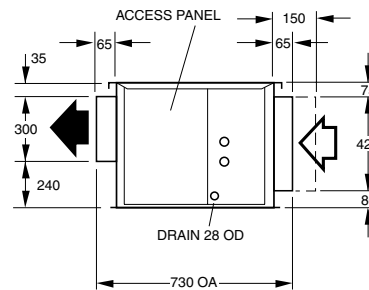
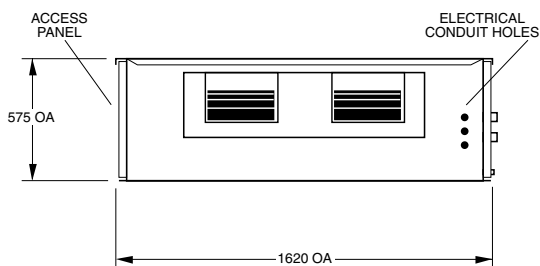
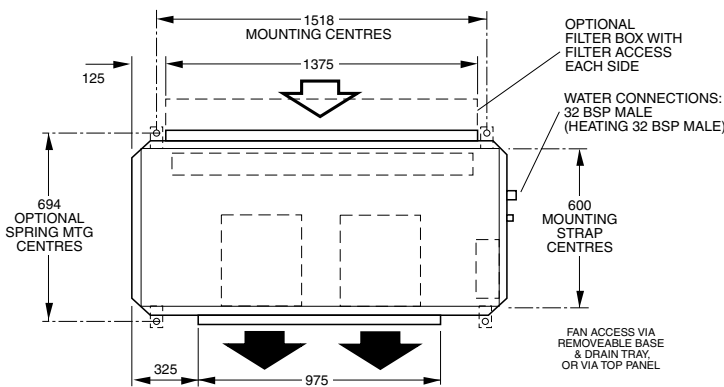

Sound Levels

Sound levels are specified as in-situ conditions. For more information and adjustment factors for your specific installation please find supplementary booklets under the relevant units on our website www.temperzone.com

Fan Speed	Vdc	RPM	Sound Power Levels (SWL) (dB)						
			dB(A)	Octave Band Centre Frequency (Hz)					
				125	250	500	1K	2K	4K
Low	7.3	1100	52	56	52	50	46	42	38
Med	8.3	1250	56	61	57	55	50	47	44
High	9.3	1400	63	67	64	62	57	54	52

IMD 550Y

				Low Air flow			Medium Air flow			Nominal Air flow		
4 row chilled water coil				1300 L/s			1800 L/s			2350 L/s		
Air on DB/WB	W. flow L/s	P.D. kPa	Cooling kW	Entering water temp			Entering water temp			Entering water temp		
				6	7	8	6	7	8	6	7	8
23/17	2.0	9.5	total	29.5	27.1	24.6	35.2	32.5	29.3	40.5	37.2	33.8
			sensible	20.4	19.3	18.3	25.5	24.3	23.1	30.5	29.1	27.7
	3.0	20.6	total	31.7	29.3	26.6	39.3	36.1	32.8	46.1	42.3	38.5
			sensible	21.4	20.3	19.2	27.3	25.9	24.5	32.9	31.2	29.6
	4.0	32.8	total	33.2	30.5	27.8	41.6	38.2	34.7	49.5	45.2	41.4
			sensible	22.1	20.9	19.7	28.3	26.8	25.3	34.3	32.5	30.8
27/19	2.0	9.5	total	36.2	33.7	31.2	43.5	40.5	37.4	49.5	46.1	43.0
			sensible	25.2	24.2	23.1	31.7	30.5	29.2	37.8	36.4	35.2
	3.0	20.6	total	39.2	36.6	33.9	48.2	45.0	41.6	56.7	52.8	48.8
			sensible	26.6	25.4	24.3	33.7	32.3	31.0	40.7	39.1	37.5
	4.0	32.8	total	40.8	38.1	35.3	51.1	47.8	44.1	60.6	56.2	52.3
			sensible	27.3	26.1	24.9	35.0	33.5	32.0	42.3	40.5	38.9
31/21	2.0	9.5	total	43.3	40.9	38.3	52.0	49.0	45.9	59.5	56.0	52.1
			sensible	30.0	28.9	27.9	37.6	36.5	35.3	45.1	43.7	42.3
	3.0	20.6	total	47.1	44.4	41.7	57.9	54.4	51.1	67.7	63.6	59.6
			sensible	31.6	30.4	29.2	40.1	38.7	37.3	48.2	46.7	45.1
	4.0	32.8	total	49.1	46.3	43.5	61.6	58.1	54.5	73.1	68.6	64.5
			sensible	32.5	31.2	30.0	41.6	40.1	38.7	50.4	48.6	47.0
35/24	2.0	9.5	total	55.1	52.6	49.9	65.5	62.3	59.0	74.1	70.4	66.7
			sensible	33.9	32.8	31.8	42.1	40.9	39.8	50.0	48.7	47.5
	3.0	20.6	total	60.0	57.2	54.3	73.6	70.1	66.5	85.3	81.2	76.9
			sensible	35.8	34.7	33.5	45.2	43.8	42.5	54.1	52.5	51.0
	4.0	32.8	total	62.7	60.0	57.0	78.5	74.7	70.9	92.5	88.0	83.5
			sensible	37.0	35.9	34.6	47.1	45.7	44.2	56.8	55.1	53.4
1 row heating water coil												
Air on DB	W. flow L/s	P.D. kPa	Heating kW	Entering water temp			Entering water temp			Entering water temp		
				50	65	80	50	65	80	50	65	80
7	0.4	4.5	heat	26.2	34.1	44.5	30.1	40.6	51.1	33.4	45.1	56.8
	0.8	15.4	heat	30.0	39.0	50.9	35.8	48.3	60.8	40.7	54.9	69.1
	1.2	31.5	heat	32.0	41.7	54.3	38.7	52.2	65.7	44.8	60.4	76.1
15	0.4	4.5	heat	21.2	30.4	39.4	24.4	34.9	45.4	27.2	38.8	50.4
	0.8	15.4	heat	24.3	34.6	45.1	29.0	41.4	53.9	33.0	47.1	61.3
	1.2	31.5	heat	25.9	37.0	48.1	31.5	45.0	58.5	36.3	51.9	67.4
21	0.4	4.5	heat	17.5	26.6	35.7	20.2	30.6	41.1	22.5	34.0	45.6
	0.8	15.4	heat	20.0	30.4	40.7	24.0	36.3	48.7	27.2	41.3	55.4
	1.2	31.5	heat	21.4	32.4	43.5	26.0	39.4	52.8	30.0	45.4	60.9

Performance Data

IMD 550Y

Air Handling

Notes:

1. Air flows given are for a unit with no filter installed.
2. In a free blown application, beware of exceeding indoor fan motor's full load amp limit.
3. Airflows are for dry coil. Reduce airflow by 10% in high moisture removal conditions. Refer to page 70 for filter pressure drop.

Dimensions

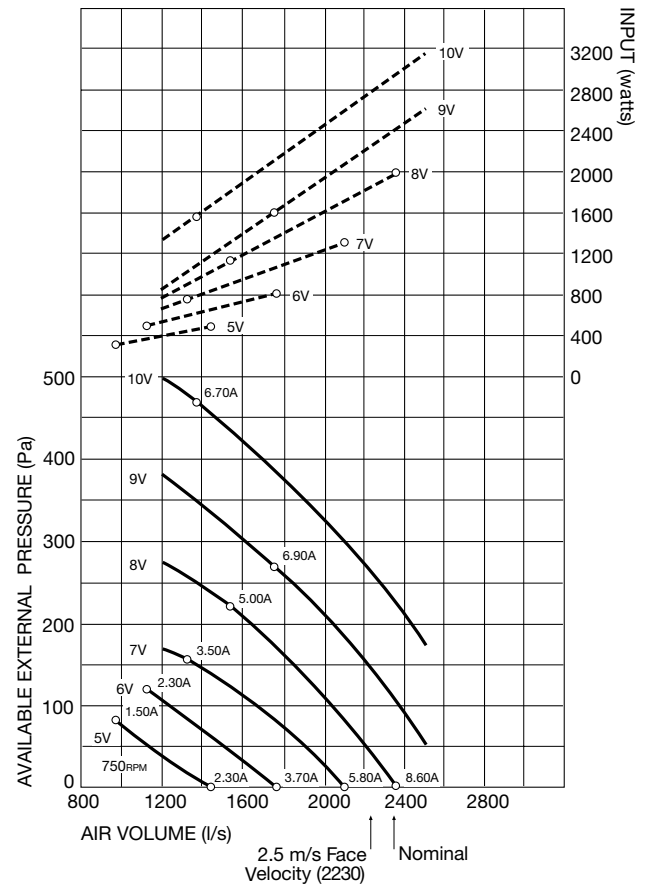
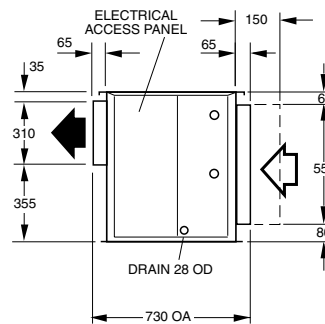
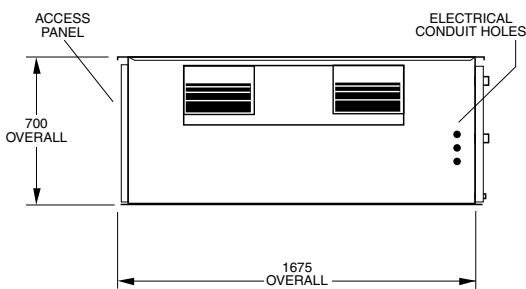
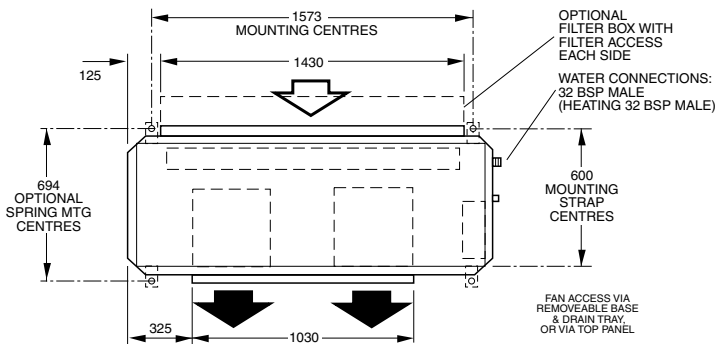

Sound Levels

Sound levels are specified as in-situ conditions. For more information and adjustment factors for your specific installation please find supplementary booklets under the relevant units on our website www.temperzone.com

Fan Speed	Vdc	RPM	Sound Power Levels (SWL) (dB)						
			dB(A)	Octave Band Centre Frequency (Hz)					
				125	250	500	1K	2K	4K
Low	6	900	56	58	54	54	51	47	45
Med	8	1200	63	65	62	61	58	55	53
High	10	1500	69	70	67	66	63	64	59

Advantage Range (AHU)

IJD



Variable Pitch Pulley



High Static Pressure



Vertical Fan Discharge



Opposite Hand



Advantage Range (IJD) Specifications



Model	IJD 370	IJD 450	IJD 620	IJD 950	IJD 1400	IJD 2000	IJD 2400
Nominal Air Flow (l/s) *	1400	1800	2200	3200	5000	7500	9000
Fan Type	Forward curved centrifugal double inlet double width belt driven						
Motor Type	Aluminium foot mounted TEFC IP55						
Power Source **	3 Phase 415V 50 Hz						
Motor Rating	2.2	2.2	3.0	4.0	7.5	(2x) 5.5	(2x) 5.5
Full Load Amps (A) ***	5	5	6.7	8.7	15.7	20.6	20.6
Optional Electric Heating (kW)	12	18	18	27	36	48	54
Electric Heat Current (A/ph)	17.6/3	26.4/3	26.4/3	39.6/3	52.8/3	70.4/3	79.2/3
Heat Exchanger Type	Epoxy aluminium corrugated plate fins to expanded rifled copper tube						
Cooling/Heating Medium	Chilled Water / Hot Water / Electric Heat						
Finish	Zinc galvanised steel						
Test Pressure	2100 kPa						
Connection Sizes 4 Row Cooling Coil (mm)	Ø 32 (1¼" BSP)	Ø 32 (1¼" BSP)	Ø 32 (1¼" BSP)	Ø 40 (1½" BSP)	Ø 50 (2" BSP)	(2x) Ø 50 (2" BSP)	(2x) Ø 50 (2" BSP)
Connection Sizes 6 Row Cooling Coil (mm)	Ø 32 (1¼" BSP)	Ø 40 (1½" BSP)	Ø 40 (1½" BSP)	Ø 40 (1½" BSP)	Ø 50 (2" BSP)	(2x) Ø 50 (2" BSP)	(2x) Ø 50 (2" BSP)
Connection Sizes 1 Row Heating Coil (mm)	Ø 32 (1¼" BSP)	Ø 32 (1¼" BSP)	Ø 32 (1¼" BSP)	Ø 40 (1½" BSP)	Ø 50 (2" BSP)	(2x) Ø 50 (2" BSP)	(2x) Ø 50 (2" BSP)
Optional Filter type	Disposable Extended Surface EU4/G4 Rated						
Optional Filter Qty	2	3	3	3+3	4+4	12	12
Optional Filter Size (mm)	625x500x50	625x400x50	625x500x50	400x500x50 500x500x50	450x500x50 500x500x50	500x500x50	600x500x50
Weight (4/1) Inc. Water (kg)	180	217	245	316	445	657	809
Nett Dry Weight (4/1) (kg)	166	201	224	285	398	583	723
Shipping Weight (kg)	184	218	242	315	428	620	760

* with no filters fitted and with a dry coil surface

** Voltage fluctuation limits 3 phase power supply, 342-436 V a.c 50 Hz.

*** Excluding Electric Heating

Cooling and Heating Coil options

- 4 Row Cooling only
- 4 Row Cooling + 1 Row Heating
- 4 Row Cooling + Electric Heating
- 6 Row Cooling only
- 6 Row Cooling + 1 Row Heating
- 6 Row Cooling + Electric Heating

Configuration options

- Horizontal / Vertical Supply Air
- Standard / Opposite Hand

IJD 370

			Low Air flow (approx 1.5m/s)						Nominal Air flow (approx 2.5m/s)					
4 row chilled water coil			800 L/s						1400 L/s					
Air on DB/WB	W. flow L/s	P.D. kPa	Entering water temp						Entering water temp					
			6		7		8		6		7		8	
			T kW	S kW	T kW	S kW	T kW	S kW	T kW	S kW	T kW	S kW	T kW	S kW
23/17	1.0	3.4	16.7	11.9	15.4	11.4	13.9	10.8	21.7	17.2	19.9	16.5	18.1	15.8
	2.0	11.8	19.3	13.1	17.6	12.3	16.1	11.7	26.9	19.4	24.8	18.5	22.6	17.6
	3.0	24.5	20.4	13.6	18.8	12.8	17.1	12.1	29.8	20.7	27.4	19.6	24.9	18.6
27/19	1.0	3.4	20.5	14.8	19.1	14.2	17.6	13.6	26.6	21.4	24.7	20.7	22.8	20.0
	2.0	11.8	23.7	16.1	22.0	15.4	20.5	14.7	33.1	24.1	30.9	23.1	28.6	22.2
	3.0	24.5	25.1	16.8	23.5	16.0	21.8	15.3	36.7	25.5	34.2	24.5	31.7	23.4
31/21	1.0	3.4	24.5	17.5	23.1	17.0	21.7	16.4	31.6	25.5	29.7	24.8	27.8	24.1
	2.0	11.8	28.4	19.1	26.8	18.5	25.1	17.8	39.7	28.6	37.2	27.6	34.9	26.7
	3.0	24.5	30.2	19.9	28.4	19.2	26.6	18.4	44.2	30.4	41.6	29.3	39.0	28.3
35/24	1.0	3.4	30.9	19.6	29.4	19.1	27.9	18.5	39.3	28.2	37.4	27.5	35.4	26.8
	2.0	11.8	36.1	21.7	34.4	21.0	32.7	20.3	50.1	32.0	47.7	31.1	45.2	30.2
	3.0	24.5	38.6	22.8	36.9	22.0	35.1	21.3	56.0	34.2	53.2	33.2	50.5	32.1
6 row chilled water coil														
23/17	1.0	4.9	19.1	13.2	17.6	12.5	16.1	11.8	25.7	19.2	23.6	18.4	21.6	17.5
	2.0	17.2	21.6	14.3	19.9	13.5	18.1	12.7	31.5	21.8	29.0	20.6	26.4	19.5
	3.0	58.8	22.6	14.8	20.7	13.9	18.9	13.1	34.4	23.1	31.7	21.9	28.9	20.6
27/19	1.0	4.9	23.5	16.3	22.0	15.6	20.4	14.9	31.5	23.9	29.4	23.0	27.3	22.2
	2.0	17.2	26.6	17.7	24.8	16.9	23.1	16.1	38.9	27.0	36.2	25.9	33.6	24.7
	3.0	35.8	27.7	18.2	26.0	17.4	24.1	16.5	42.4	28.6	39.6	27.3	36.8	26.1
31/21	1.0	4.9	28.2	19.3	26.6	18.7	25.0	18.0	37.7	28.4	35.6	27.6	33.4	26.8
	2.0	17.2	31.9	21.0	30.1	20.2	28.3	19.4	46.6	32.0	44.0	30.9	41.3	29.9
	3.0	35.8	33.5	21.7	31.7	20.9	29.8	20.1	50.9	33.9	48.2	32.7	45.2	31.5
35/24	1.0	4.9	35.7	21.8	34.0	21.1	32.4	20.5	46.8	31.5	44.5	30.7	42.4	29.9
	2.0	17.2	40.6	24.0	38.8	23.1	37.0	22.4	58.8	36.0	56.0	35.0	53.2	33.9
	3.0	35.8	42.7	24.9	40.7	24.0	38.9	23.2	64.6	38.4	61.6	37.2	58.6	35.9
1 row hot water coil														
Air on DB	W. flow L/s	P.D. kPa	Entering water temp			Entering water temp								
			50	65	80	50	65	80						
7	0.5	1.3	17.3	23.3	29.3	22.6	30.5	38.5						
	1.0	4.8	18.8	25.4	32.0	25.7	34.7	43.6						
	2.0	15.6	20.6	27.8	35.0	28.9	38.9	48.9						
15	0.5	1.3	14.0	20.0	26.0	18.4	26.2	34.1						
	1.0	4.8	15.3	21.8	28.3	20.8	29.7	38.7						
	2.0	15.6	16.6	23.8	30.9	23.4	33.4	43.4						
21	0.5	1.3	11.6	17.6	23.6	15.2	23.0	30.9						
	1.0	4.8	12.6	19.1	25.6	17.2	26.1	35.0						
	2.0	15.6	13.6	20.8	27.8	19.2	29.2	39.2						

Performance Data

IJD 370

Air Handling

Notes:

1. Air flows given are for a unit with no filter installed.
2. In a free blown application, beware of exceeding indoor fan motor's full load amp limit.
3. Airflows are for dry coil. Reduce airflow by 10% in high moisture removal conditions. Refer to page 70 for filter pressure drop.

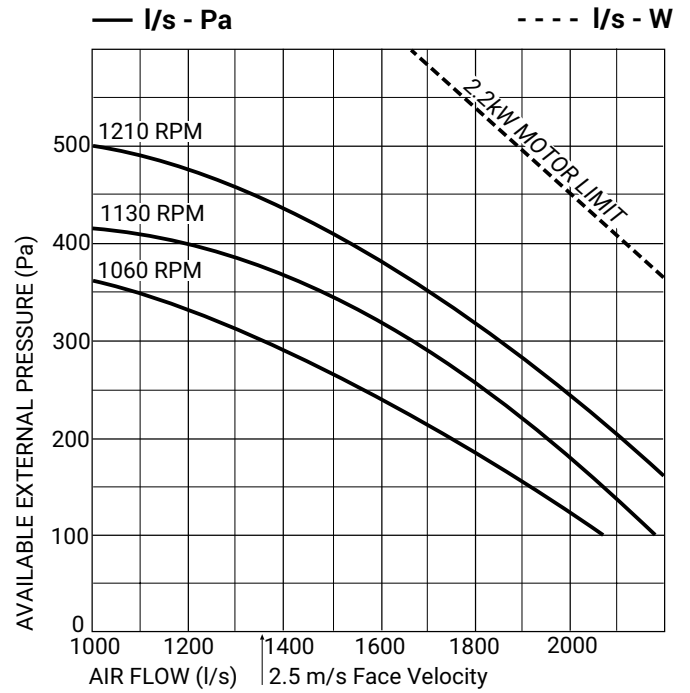

Dimensions

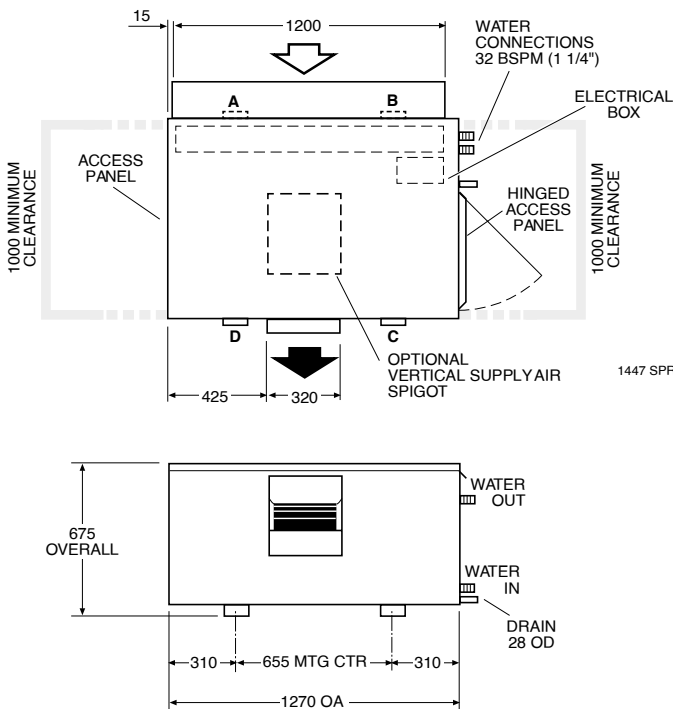

Point Loads			
A	B	C	D
40	52	50	38

*4/1 row coil including water

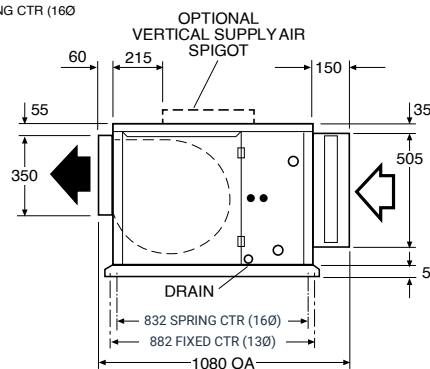

Sound Levels

Test Conditions: BS 848 PT2 1985
Installation Type A (free inlet and outlet)
Direct method of measurement (reverberant room)
Measured in decibels re 1 picowatt

Fan Speed	Sound Power Levels (SWL) (dB)						
	dB(A)	Octave Band Centre Frequency (Hz)					
		125	250	500	1K	2K	4K
1060	82	79	78	79	77	75	70
1130	84	80	79	81	79	77	72
1210	86	81	80	82	82	79	75

IJD 450

			Low Air flow (approx 1.5m/s)						Nominal Air flow (approx 2.5m/s)					
4 row chilled water coil			1000 L/s						1800 L/s					
Air on DB/WB	W. flow L/s	P.D. kPa	Entering water temp						Entering water temp					
			6		7		8		6		7		8	
			T kW	S kW	T kW	S kW	T kW	S kW	T kW	S kW	T kW	S kW	T kW	S kW
23/17	2.0	7.9	23.1	15.9	21.2	15.0	19.3	14.2	32.3	23.9	29.6	22.8	26.8	21.6
	3.0	16.7	24.6	16.6	22.7	15.7	20.7	14.8	36.0	25.5	33.3	24.3	30.1	23.0
	4.0	26.0	25.7	17.1	23.7	16.1	21.5	15.2	38.6	26.6	35.4	25.2	32.3	23.9
27/19	2.0	7.9	28.3	19.6	26.4	18.8	24.5	18.0	39.4	29.6	36.6	28.5	34.1	27.5
	3.0	16.7	30.4	20.5	28.4	19.7	26.4	18.8	44.4	31.6	41.2	30.3	38.4	29.2
	4.0	26.0	31.7	21.1	29.5	20.1	27.4	19.2	47.5	32.9	44.3	31.6	41.0	30.2
31/21	2.0	7.9	34.0	23.3	32.1	22.5	30.0	21.7	47.1	35.1	44.2	34.0	41.6	33.1
	3.0	16.7	36.6	24.4	34.5	23.5	32.4	22.7	53.2	37.5	49.8	36.2	46.9	35.1
	4.0	26.0	38.1	25.1	35.9	24.1	33.8	23.2	56.8	39.0	53.7	37.8	50.4	36.4
35/24	2.0	7.9	43.4	26.4	41.2	25.5	39.2	24.8	59.2	39.2	56.2	38.1	53.2	37.1
	3.0	16.7	46.8	27.8	44.5	26.9	42.3	26.0	67.2	42.1	63.9	40.9	60.5	39.7
	4.0	26.0	48.7	28.6	46.4	27.7	44.3	26.8	72.3	44.1	68.8	42.7	65.3	41.4
6 row chilled water coil														
23/17	1.5	6.6	24.9	16.9	22.9	16.0	20.8	15.1	34.8	25.5	31.8	24.2	29.1	23.1
	2.5	17.0	27.0	17.9	24.8	16.9	22.6	15.9	40.2	27.8	37.1	26.5	33.8	25.0
	3.5	31.5	28.0	18.4	25.8	17.3	23.6	16.3	43.2	29.2	40.0	27.7	36.3	26.1
27/19	1.5	6.6	30.6	20.9	28.5	20.0	26.5	19.1	42.4	31.5	39.7	30.4	37.0	29.3
	2.5	17.0	33.3	22.1	31.1	21.1	28.8	20.1	49.5	34.5	46.2	33.1	42.8	31.6
	3.5	31.5	34.6	22.7	32.3	21.7	30.0	20.6	53.5	36.2	49.8	34.6	46.0	33.0
31/21	1.5	6.6	36.7	24.8	34.6	23.9	32.5	23.0	51.0	37.5	48.2	36.4	45.0	35.2
	2.5	17.0	39.9	26.3	37.7	25.3	35.4	24.3	59.5	41.0	56.1	39.6	52.5	38.1
	3.5	31.5	41.5	27.0	39.4	26.0	37.0	25.0	63.9	42.9	60.5	41.4	56.6	39.8
35/24	1.5	6.6	46.3	28.0	44.3	27.2	42.2	26.3	63.5	41.6	60.4	40.5	57.3	39.4
	2.5	17.0	50.8	29.9	48.4	28.9	46.3	28.0	74.7	45.9	71.2	44.5	67.8	43.2
	3.5	31.5	52.8	30.8	50.6	29.8	48.3	28.9	81.1	48.5	77.6	47.1	73.7	45.5
1 row hot water coil														
Air on DB	W. flow L/s	P.D. kPa	Entering water temp			Entering water temp								
			50	65	80	50	65	80						
7	0.5	1.0	21.1	28.4	35.8	27.4	37.0	46.6						
	1.0	3.3	23.0	31.0	39.0	31.3	42.2	53.1						
	2.0	10.7	25.1	33.8	42.6	35.2	47.6	59.9						
15	0.5	1.0	17.1	24.4	31.7	22.2	31.8	41.2						
	1.0	3.3	18.6	26.5	34.5	25.4	36.2	47.1						
	2.0	10.7	20.2	28.8	37.5	28.5	40.8	53.1						
21	0.5	1.0	14.1	21.4	28.7	18.4	27.9	37.4						
	1.0	3.3	15.3	23.2	31.2	20.9	31.8	42.6						
	2.0	10.7	16.6	25.2	33.9	23.6	35.8	48.0						

Performance Data

IJD 450

Air Handling

Notes:

1. Air flows given are for a unit with no filter installed.
2. In a free blown application, beware of exceeding indoor fan motor's full load amp limit.
3. Airflows are for dry coil. Reduce airflow by 10% in high moisture removal conditions. Refer to page 70 for filter pressure drop.

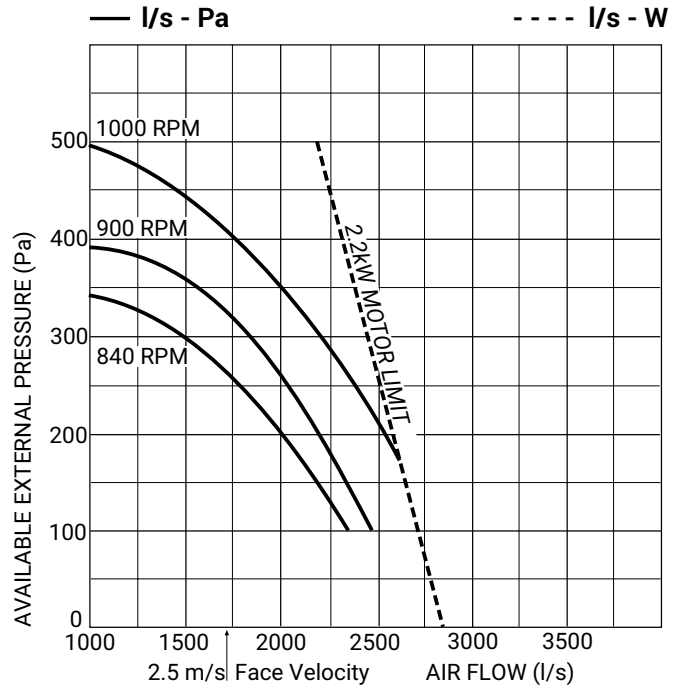

Dimensions

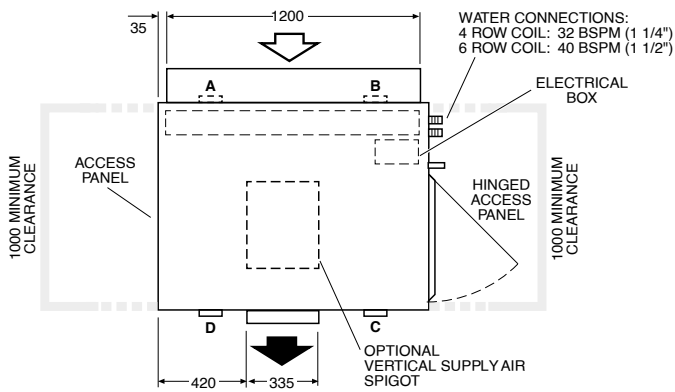

Point Loads			
A	B	C	D
61	74	47	35

*4/1 row coil including water

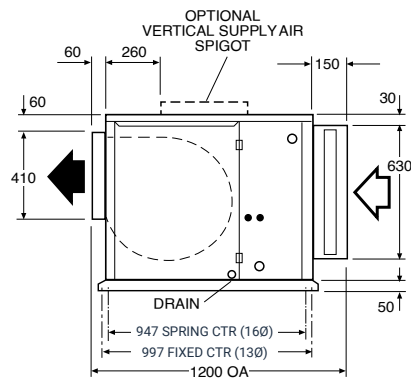
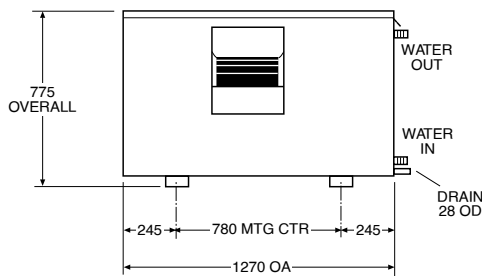

Sound Levels

Test Conditions: BS 848 PT2 1985
Installation Type A (free inlet and outlet)
Direct method of measurement (reverberant room)
Measured in decibels re 1 picowatt

Fan Speed	Sound Power Levels (SWL) (dB)						
	dB(A)	Octave Band Centre Frequency (Hz)					
		125	250	500	1K	2K	4K
840	84	86	82	80	78	77	76
900	89	87	84	84	83	82	81
1000	94	88	86	88	90	87	87

IJD 620

			Low Air flow (approx 1.5m/s)						Nominal Air flow (approx 2.5m/s)					
4 row chilled water coil			1600 L/s						2200 L/s					
Air on DB/WB	W. flow L/s	P.D. kPa	Entering water temp						Entering water temp					
			6		7		8		6		7		8	
			T kW	S kW	T kW	S kW	T kW	S kW	T kW	S kW	T kW	S kW	T kW	S kW
23/17	1.5	5.5	29.9	22.1	27.5	21.1	25.0	20.1	34.7	27.2	31.9	26.1	29.0	24.9
	2.5	13.9	34.4	24.1	31.6	22.8	28.6	21.6	41.3	30.0	37.8	28.5	34.3	27.1
	3.5	24.7	36.9	25.2	33.9	23.8	30.8	22.5	45.1	31.6	41.4	30.0	37.7	28.5
27/19	1.5	5.5	36.8	27.5	34.3	26.5	31.6	25.4	42.4	33.9	39.5	32.8	36.6	31.6
	2.5	13.9	42.2	29.8	39.3	28.5	36.4	27.4	50.5	37.1	47.0	35.7	43.5	34.3
	3.5	24.7	45.3	31.1	42.2	29.8	39.2	28.5	55.5	39.2	51.7	37.6	47.8	36.0
31/21	1.5	5.5	44.0	32.7	41.4	31.7	38.8	30.7	50.8	40.4	47.6	39.2	44.5	38.1
	2.5	13.0	50.6	35.3	47.6	34.1	44.7	33.0	60.4	44.1	56.8	42.6	53.2	41.3
	3.5	24.7	54.6	37.1	51.5	35.7	48.3	34.4	66.5	46.5	62.6	44.9	58.7	43.4
35/24	1.5	5.5	55.1	36.4	52.4	35.4	49.7	34.4	62.9	44.5	59.7	43.5	56.6	42.5
	2.5	13.9	64.3	39.8	61.2	38.6	58.1	37.5	76.1	49.2	72.3	47.9	68.5	46.5
	3.5	24.7	69.5	41.9	66.2	40.6	62.8	39.3	84.1	52.2	80.0	50.7	76.1	49.2
6 row chilled water coil														
23/17	1.5	7.8	34.9	24.6	32.1	23.4	29.2	22.2	40.9	30.4	37.6	29.0	34.3	27.6
	2.5	19.9	39.3	26.7	36.2	25.2	33.0	23.8	48.2	33.6	44.3	31.9	40.3	30.2
	3.5	36.3	41.9	27.8	38.5	26.3	35.1	24.8	52.2	35.3	48.0	33.5	43.8	31.7
27/19	1.5	7.8	42.8	30.5	39.9	29.3	37.0	28.1	50.3	37.8	46.8	36.5	43.4	35.1
	2.5	19.8	48.4	33.0	45.1	31.5	41.9	30.2	59.2	41.6	55.2	39.9	51.2	38.2
	3.5	36.3	51.5	34.4	48.1	32.9	44.6	31.3	64.2	43.8	60.0	41.9	55.6	40.1
31/21	1.5	7.8	51.3	36.3	48.5	35.1	45.5	33.9	59.9	44.9	56.6	43.6	53.1	42.3
	2.5	19.8	58.2	39.2	55.0	37.8	51.6	36.4	70.9	49.3	66.8	47.1	62.8	46.0
	3.5	36.3	61.9	40.9	58.5	39.3	54.9	37.8	77.1	51.9	72.7	50.1	68.3	48.3
35/24	1.5	7.8	64.4	40.6	61.4	39.5	58.3	38.3	74.5	49.8	70.9	48.5	67.4	47.2
	2.5	19.8	73.8	44.4	70.4	43.0	66.9	41.6	89.1	55.2	85.2	53.7	80.9	52.1
	3.5	36.3	78.8	46.5	75.2	45.0	71.5	43.5	97.8	58.7	93.3	56.9	88.7	55.1
1 row hot water coil														
Air on DB	W. flow L/s	P.D. kPa	Entering water temp			Entering water temp								
			50	65	80	50	65	80						
7	1.0	3.6	32.2	43.5	54.7	37.7	50.8	64.0						
	1.5	7.3	34.4	46.4	58.4	40.7	54.9	69.1						
	2.0	12.3	35.5	47.9	60.3	42.8	57.7	72.6						
15	1.0	3.6	26.1	37.3	48.5	30.5	43.6	56.7						
	1.5	7.3	27.8	39.7	51.6	33.0	47.1	61.3						
	2.0	12.3	28.7	41.1	53.4	34.7	49.5	64.4						
21	1.0	3.6	21.5	32.7	43.8	25.2	38.2	51.3						
	1.5	7.3	23.0	34.9	46.7	27.2	41.3	55.4						
	2.0	12.3	23.8	36.0	48.3	28.6	43.4	58.2						

Performance Data

IJD 620

Air Handling

Notes:

1. Air flows given are for a unit with no filter installed.
2. In a free blown application, beware of exceeding indoor fan motor's full load amp limit.
3. Airflows are for dry coil. Reduce airflow by 10% in high moisture removal conditions. Refer to page 70 for filter pressure drop.

Dimensions

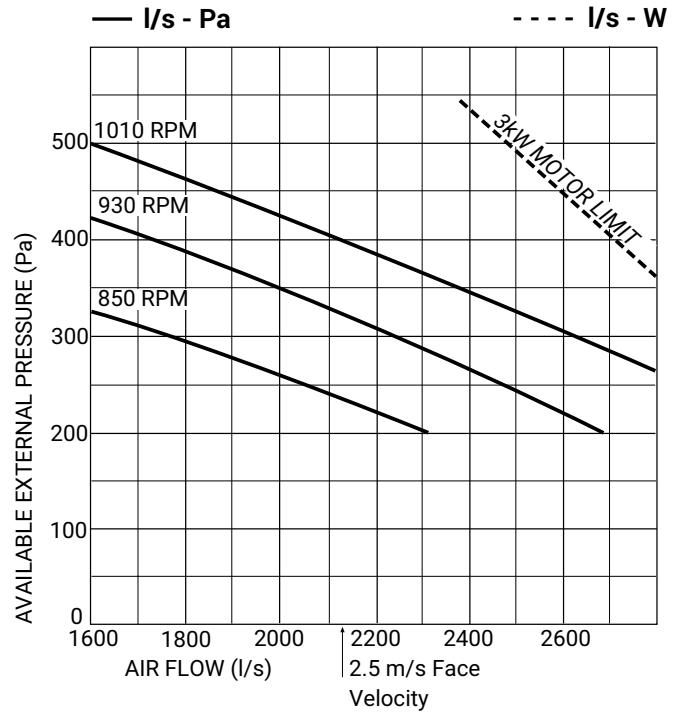
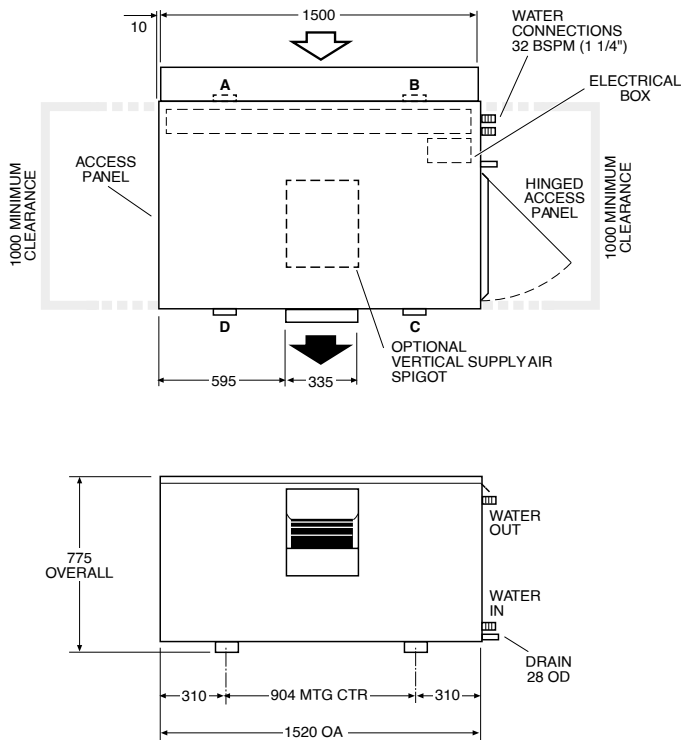

Point Loads			
A	B	C	D
69	83	54	39

*4/1 row coil including water

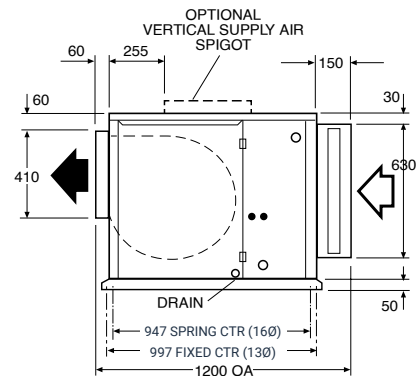

Sound Levels

Test Conditions: BS 848 PT2 1985
 Installation Type A (free inlet and outlet)
 Direct method of measurement (reverberant room)
 Measured in decibels re 1 picowatt

Fan Speed	Sound Power Levels (SWL) (dB)						
	dB(A)	Octave Band Centre Frequency (Hz)					
		125	250	500	1K	2K	4K
850	88	84	83	83	84	82	79
930	91	86	84	85	87	86	81
1010	94	87	85	87	91	90	84

IJD 950

			Low Air flow (approx 1.5m/s)						Nominal Air flow (approx 2.5m/s)					
4 row chilled water coil			2000 L/s						3200 L/s					
Air on DB/WB	W. flow L/s	P.D. kPa	Entering water temp						Entering water temp					
			6		7		8		6		7		8	
			T kW	S kW	T kW	S kW	T kW	S kW	T kW	S kW	T kW	S kW	T kW	S kW
23/17	2.5	7.7	42.7	30.1	39.1	28.6	35.6	27.1	54.1	41.2	49.5	39.3	45.1	37.5
	3.5	14.0	45.9	31.6	42.1	29.9	38.4	28.3	60.3	43.8	55.3	41.7	50.3	39.6
	4.5	22.6	48.1	32.6	44.3	30.9	40.3	29.1	64.6	45.7	59.4	43.5	54.2	41.2
27/19	2.5	7.7	52.3	37.3	48.8	35.8	45.2	34.3	66.2	51.1	61.5	49.3	57.0	47.6
	3.5	14.0	56.4	39.1	52.6	37.4	48.7	35.8	73.9	54.3	68.8	52.2	63.7	50.2
	4.5	22.6	59.3	40.3	55.3	38.5	51.2	36.8	79.6	56.7	74.1	54.4	68.6	52.2
31/21	2.5	7.7	62.7	44.3	59.1	42.8	55.3	41.3	79.3	61.0	74.1	59.0	69.5	57.3
	3.5	14.0	67.6	46.3	63.8	44.8	60.0	43.2	88.5	64.5	83.1	62.4	78.0	60.4
	4.5	22.6	71.3	47.9	67.1	46.1	63.0	44.4	95.4	67.2	89.7	65.0	84.1	62.8
35/24	2.5	7.7	79.1	49.7	75.6	48.3	71.6	46.9	98.6	67.5	93.7	65.7	88.7	64.1
	3.5	14.0	86.2	52.5	82.1	50.8	77.9	49.2	111.4	72.0	105.8	70.1	100.4	68.1
	4.5	22.6	90.6	54.3	86.3	52.6	82.5	51.0	120.2	75.3	114.8	73.3	108.9	71.1
6 row chilled water coil														
23/17	2.5	11.1	48.7	33.3	44.6	31.5	40.8	29.8	63.5	46.0	58.3	43.8	53.1	41.7
	3.5	20.6	51.8	34.7	47.8	32.9	43.6	31.0	70.4	49.1	64.8	46.6	59.1	44.2
	4.5	31.9	54.1	35.7	49.7	33.8	45.3	31.7	74.9	51.1	68.8	48.4	62.8	45.8
27/19	2.5	11.1	59.8	41.1	55.8	39.4	51.9	37.6	77.8	57.1	72.6	54.9	67.4	52.8
	3.5	20.6	63.9	43.0	59.7	41.1	55.5	39.3	86.5	60.7	80.7	58.3	74.9	55.9
	4.5	31.9	66.5	44.2	62.2	42.2	57.7	40.2	92.1	63.2	85.9	60.5	79.7	57.9
31/21	2.5	11.1	71.7	48.8	67.6	47.1	63.6	45.4	92.9	67.7	87.8	65.7	82.3	63.5
	3.5	20.6	76.9	51.1	72.6	49.2	68.2	47.3	103.7	72.1	97.9	69.7	91.6	67.2
	4.5	31.9	79.9	52.5	75.5	50.5	70.9	48.5	110.5	75.0	104.1	72.3	97.9	69.7
35/24	2.5	11.1	90.9	55.2	86.7	53.5	82.4	51.8	116.5	75.5	110.8	73.5	105.3	71.4
	3.5	20.6	97.6	58.0	93.2	56.2	88.6	54.3	130.2	80.8	124.1	78.4	118.3	76.2
	4.5	31.9	101.6	59.8	97.2	57.9	92.7	56.0	140.0	84.7	133.5	82.1	126.9	79.5
1 row hot water coil														
Air on DB	W. flow L/s	P.D. kPa	Entering water temp			Entering water temp								
			50	65	80	50	65	80						
7	1.0	2.1	41.6	56.1	70.6	51.7	69.7	87.7						
	2.0	7.2	45.8	61.8	77.7	59.3	80.0	100.8						
	3.0	14.7	48.3	65.2	82.1	63.9	86.2	108.6						
15	1.0	2.1	33.7	48.1	62.6	41.9	59.8	77.8						
	2.0	7.2	37.1	52.9	68.8	48.1	68.7	89.3						
	3.0	14.7	39.1	55.9	72.7	51.8	73.9	96.1						
21	1.0	2.1	27.8	42.2	56.6	34.6	52.5	70.4						
	2.0	7.2	30.5	46.3	62.2	39.6	60.2	80.7						
	3.0	14.7	32.3	49.0	65.7	42.7	64.9	87.0						

Performance Data

IJD 950

Air Handling

Notes:

1. Air flows given are for a unit with no filter installed.
2. In a free blown application, beware of exceeding indoor fan motor's full load amp limit.
3. Airflows are for dry coil. Reduce airflow by 10% in high moisture removal conditions. Refer to page 70 for filter pressure drop.

Dimensions

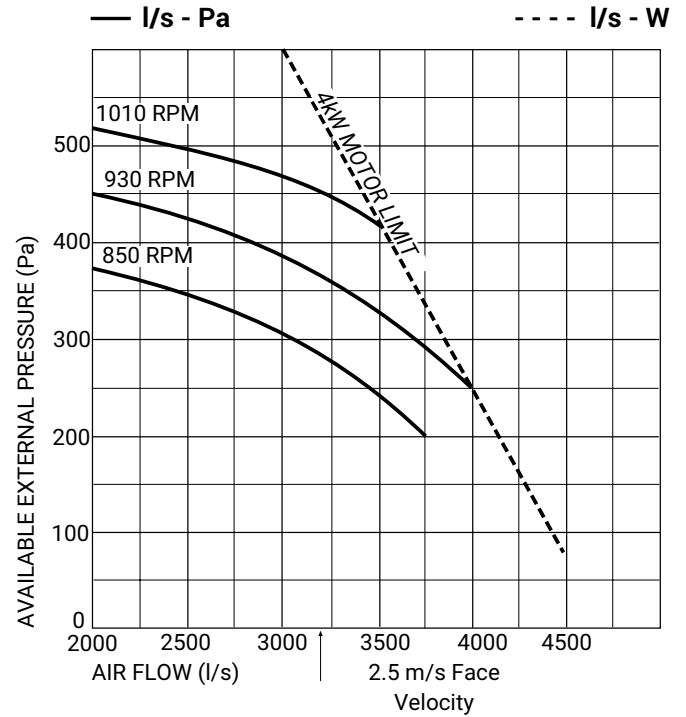
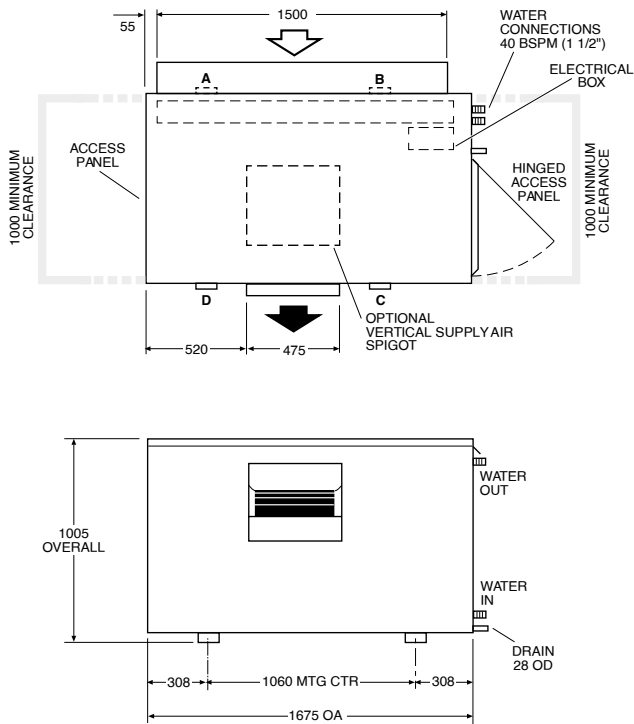

Point Loads			
A	B	C	D
95	103	64	54

*4/1 row coil including water

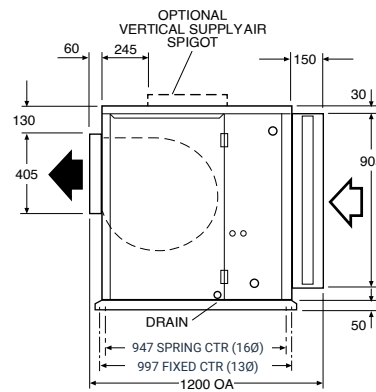

Sound Levels

Test Conditions: BS 848 PT2 1985
 Installation Type A (free inlet and outlet)
 Direct method of measurement (reverberant room)
 Measured in decibels re 1 picowatt

Fan Speed	Sound Power Levels (SWL) (dB)					
	dB(A)	Octave Band Centre Frequency (Hz)				
		125	250	500	1K	2K
850	88	86	84	82	82	79
930	89	86	84	82	84	81
1010	90	87	85	83	85	81

IJD 1400

			Low Air flow (approx 1.5m/s)						Nominal Air flow (approx 2.5m/s)					
4 row chilled water coil			3000 L/s						5000 L/s					
Air on DB/WB	W. flow L/s	P.D. kPa	Entering water temp						Entering water temp					
			6		7		8		6		7		8	
			T kW	S kW	T kW	S kW	T kW	S kW	T kW	S kW	T kW	S kW	T kW	S kW
23/17	2.5	9.1	59.9	43.5	55.1	41.3	50.1	39.3	74.9	60.3	68.6	57.8	62.6	55.4
	3.5	16.2	65.7	45.9	60.3	43.6	54.8	41.2	85.7	64.7	78.7	61.8	71.5	58.9
	4.5	25.5	69.7	47.8	64.0	45.2	58.2	42.7	93.6	68.1	85.9	64.8	78.1	61.6
27/19	2.5	9.1	73.7	53.9	68.5	51.8	63.5	49.8	91.5	75.1	85.3	72.7	79.2	70.3
	3.5	16.2	81.0	57.0	75.4	54.7	69.8	52.4	104.9	80.4	97.7	77.5	90.6	74.7
	4.5	25.5	85.7	59.1	79.8	56.5	74.0	54.1	114.6	84.3	106.9	81.1	99.0	78.0
31/21	2.5	9.1	87.9	64.0	82.8	61.9	77.7	60.0	109.1	89.5	102.7	87.1	96.1	84.8
	3.5	16.2	97.0	67.7	91.4	65.4	85.8	63.1	125.8	95.6	118.1	92.8	110.8	90.1
	4.5	25.5	102.8	70.1	96.8	67.6	90.8	65.1	137.1	100.1	129.1	97.0	120.9	93.9
35/24	2.5	9.1	110.5	71.5	105.3	69.5	100.9	67.6	135.2	98.7	128.5	96.5	121.5	94.2
	3.5	16.2	122.5	76.1	116.7	73.8	110.7	71.5	156.4	106.0	148.6	103.3	141.1	100.7
	4.5	25.5	130.9	79.4	124.7	76.9	118.4	74.4	172.5	111.8	164.1	108.7	155.6	105.7
6 row chilled water coil														
23/17	2.5	13.0	68.7	48.0	63.2	45.6	57.7	43.2	87.7	66.9	80.7	64.0	73.5	61.1
	3.5	23.5	74.7	50.7	68.7	48.0	62.6	45.3	99.9	72.2	92.0	68.8	83.9	65.4
	4.5	36.7	78.4	52.4	72.1	49.5	65.9	46.7	108.7	76.0	100.1	72.2	91.2	68.4
27/19	2.5	13.0	84.4	59.4	79.0	57.0	73.2	54.6	107.3	83.2	100.4	80.4	93.1	77.6
	3.5	23.5	91.8	62.6	85.7	60.0	79.6	57.3	122.5	89.4	114.5	86.1	106.2	82.8
	4.5	36.7	96.3	64.7	90.3	62.0	83.8	59.1	133.5	94.1	124.7	90.3	115.7	86.6
31/21	2.5	13.0	101.1	70.5	95.5	68.1	89.6	65.8	128.1	98.9	120.6	96.1	113.7	93.5
	3.5	23.5	110.2	74.4	104.0	71.7	97.7	69.1	147.2	106.4	138.7	103.1	130.2	99.8
	4.5	36.7	116.1	77.0	109.7	74.2	103.1	71.4	159.9	111.6	151.0	108.0	141.9	104.3
35/24	2.5	13.0	126.8	79.0	121.3	76.8	115.4	74.5	158.4	109.2	150.8	106.6	143.0	103.9
	3.5	23.5	139.7	84.3	133.3	81.6	126.8	79.0	183.3	118.3	174.7	115.1	166.0	111.9
	4.5	36.7	147.5	87.6	140.8	84.7	134.0	81.9	201.2	125.1	191.8	121.5	182.3	117.9
1 row hot water coil														
Air on DB	W. flow L/s	P.D. kPa	Entering water temp			Entering water temp								
			50	65	80	50	65	80						
7	1.5	5.0	63.9	86.2	108.5	81.4	109.8	138.2						
	2.5	11.7	69.1	93.1	117.2	91.4	123.2	155.2						
	3.5	21.2	72.6	97.9	123.2	97.6	131.6	165.7						
15	1.5	5.0	51.8	73.7	96.3	66.0	94.3	122.6						
	2.5	11.7	55.8	79.8	103.8	74.1	105.8	137.5						
	3.5	21.3	58.7	83.9	109.1	79.0	112.9	146.8						
21	1.5	5.0	42.6	64.7	86.7	54.5	82.7	110.9						
	2.5	11.7	46.1	70.0	93.8	61.1	92.8	124.4						
	3.5	21.3	48.4	73.4	98.5	65.3	99.0	132.8						

Performance Data

IJD 1400

Air Handling

Notes:

1. Air flows given are for a unit with no filter installed.
2. In a free blown application, beware of exceeding indoor fan motor's full load amp limit.
3. Airflows are for dry coil. Reduce airflow by 10% in high moisture removal conditions. Refer to page 70 for filter pressure drop.

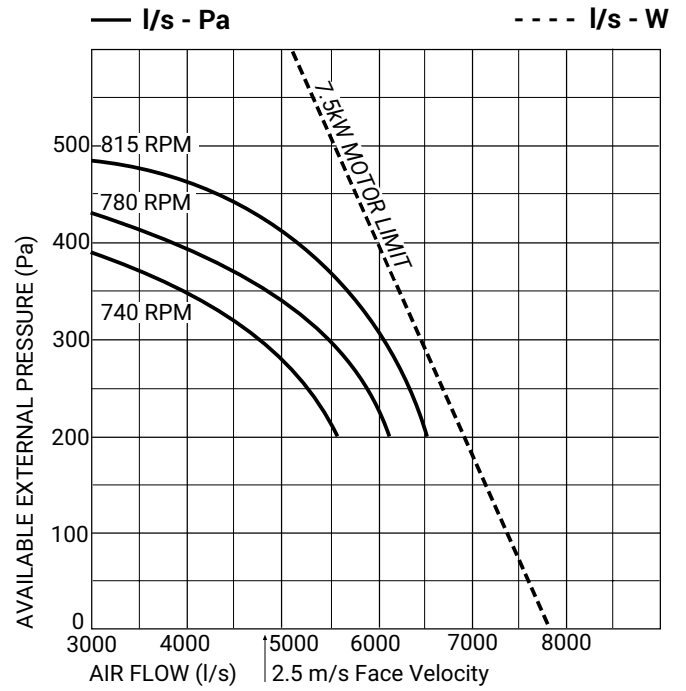

Dimensions

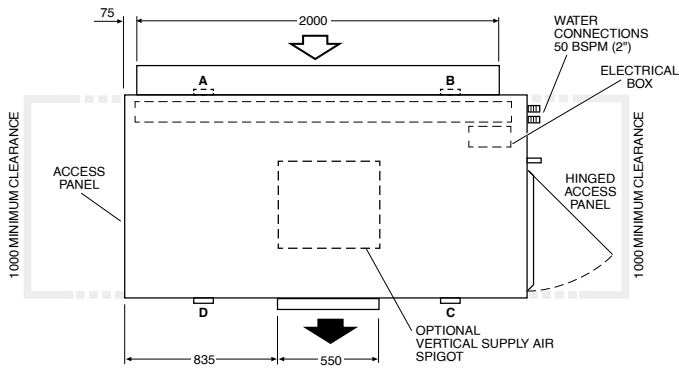

Point Loads			
A	B	C	D
115	145	107	78

*4/1 row coil including water

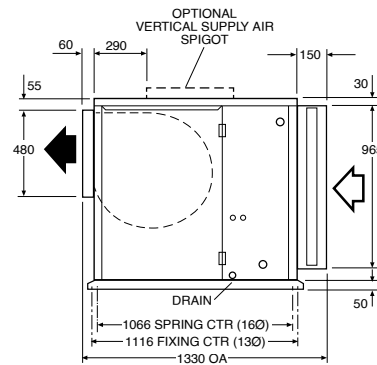
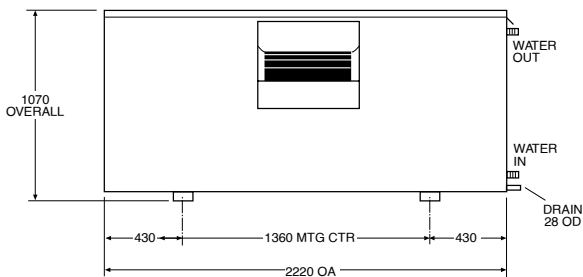

Sound Levels

Test Conditions: BS 848 PT2 1985
 Installation Type A (free inlet and outlet)
 Direct method of measurement (reverberant room)
 Measured in decibels re 1 picowatt

Fan Speed	Sound Power Levels (SWL) (dB)						
	dB(A)	Octave Band Centre Frequency (Hz)					
		125	250	500	1K	2K	4K
740	81	83	80	76	74	76	70
780	86	86	83	83	81	81	76
815	92	90	86	89	87	86	82

IJD 2000

			Low Air flow (approx 1.5m/s)						Nominal Air flow (approx 2.5m/s)					
4 row chilled water coil			4500 L/s						7500 L/s					
Air on DB/WB	W. flow L/s	P.D. kPa	Entering water temp						Entering water temp					
			6		7		8		6		7		8	
			T kW	S kW	T kW	S kW	T kW	S kW	T kW	S kW	T kW	S kW	T kW	S kW
23/17	3.5	6.9	88.2	64.5	81.0	61.4	73.8	58.4	108.9	89.2	100.3	85.7	91.4	85.2
	5.5	15.3	99.7	69.5	91.4	65.9	83.2	62.4	130.4	98.0	119.6	93.6	109.1	89.3
	7.5	27.2	106.8	72.7	98.1	68.8	89.3	64.9	144.8	104.1	133.0	99.1	120.7	94.0
27/19	3.5	6.9	107.8	79.9	100.6	76.9	93.1	73.9	133.0	111.2	123.9	107.7	115.4	104.5
	5.5	15.3	122.3	85.9	114.2	82.5	105.9	79.1	159.5	121.7	148.7	117.3	137.5	113.0
	7.5	27.2	131.1	89.8	122.4	86.0	113.4	82.2	177.5	128.9	165.3	124.0	153.2	119.1
31/21	3.5	6.9	129.0	94.9	121.5	91.9	114.0	89.0	158.6	132.6	148.5	129.0	140.2	126.0
	5.5	15.3	147.1	102.3	138.7	98.8	130.0	95.3	191.0	144.7	179.9	140.5	167.9	136.1
	7.5	27.2	157.7	106.7	148.5	102.8	139.4	99.1	212.2	153.0	199.8	148.2	187.3	143.3
35/24	3.5	6.9	161.9	105.9	154.1	103.0	146.0	100.1	195.4	145.9	185.8	142.7	176.2	139.6
	5.5	15.3	186.1	115.1	177.0	111.6	168.1	108.2	238.3	160.6	226.9	156.5	215.1	152.5
	7.5	27.2	200.1	120.7	191.4	117.2	181.8	113.4	268.1	171.3	254.7	166.4	241.3	161.6
6 row chilled water coil														
23/17	3.5	9.7	101.1	71.1	92.9	67.6	84.8	64.1	127.2	98.8	117.1	94.6	106.6	90.4
	5.5	22.5	113.1	76.6	104.1	72.5	94.9	68.4	152.2	109.4	139.9	104.1	127.7	98.9
	7.5	38.6	119.7	79.6	110.1	75.2	100.5	70.8	167.5	116.1	153.8	110.1	140.2	104.3
27/19	3.5	9.7	123.9	88.0	115.9	84.5	107.7	81.1	156.1	123.0	144.9	118.6	135.1	114.8
	5.5	22.5	139.1	94.7	129.9	90.6	120.5	86.5	186.6	135.5	173.9	130.2	161.7	125.3
	7.5	38.6	147.3	98.4	137.6	94.0	127.8	89.7	206.2	143.9	192.7	138.0	178.6	132.2
31/21	3.5	9.7	148.7	104.6	140.2	101.0	131.7	97.6	185.8	146.2	175.1	142.2	164.5	138.2
	5.5	22.5	166.9	112.4	157.5	108.3	148.1	104.3	222.9	160.7	210.3	155.8	197.5	150.7
	7.5	38.6	176.9	116.9	167.0	112.4	156.9	108.1	247.1	170.7	233.4	165.0	218.9	159.2
35/24	3.5	9.7	186.5	117.1	177.9	113.7	169.1	110.3	228.9	161.1	218.0	157.3	207.2	153.6
	5.5	22.5	210.7	127.0	201.9	123.3	192.2	119.3	279.2	179.3	265.6	174.2	252.5	169.4
	7.5	38.6	225.2	133.2	215.3	128.9	205.0	124.5	310.8	191.4	296.2	185.7	281.2	180.0
1 row hot water coil														
Air on DB	W. flow L/s	P.D. kPa	Entering water temp			Entering water temp								
			50	65	80	50	65	80						
7	2.0	3.3	94.3	127.1	160.0	119.2	160.7	202.2						
	4.0	11.4	104.9	141.5	178.1	139.1	187.7	236.2						
	6.0	23.4	111.6	150.7	189.4	150.7	203.3	255.9						
15	2.0	3.3	76.3	109.1	141.8	96.6	138.0	179.3						
	4.0	11.4	84.9	121.2	157.7	112.6	161.1	209.4						
	6.0	23.4	90.0	128.6	167.1	122.1	174.4	226.7						
21	2.0	3.3	63.1	95.7	128.3	79.9	121.1	162.4						
	4.0	11.4	70.0	106.2	142.5	93.1	141.2	189.4						
	6.0	23.4	74.2	112.6	151.0	100.7	152.9	204.9						

Performance Data

IJD 2000

Air Handling

Notes:

1. Air flows given are for a unit with no filter installed.
2. In a free blown application, beware of exceeding indoor fan motor's full load amp limit.
3. Airflows are for dry coil. Reduce airflow by 10% in high moisture removal conditions. Refer to page 70 for filter pressure drop.

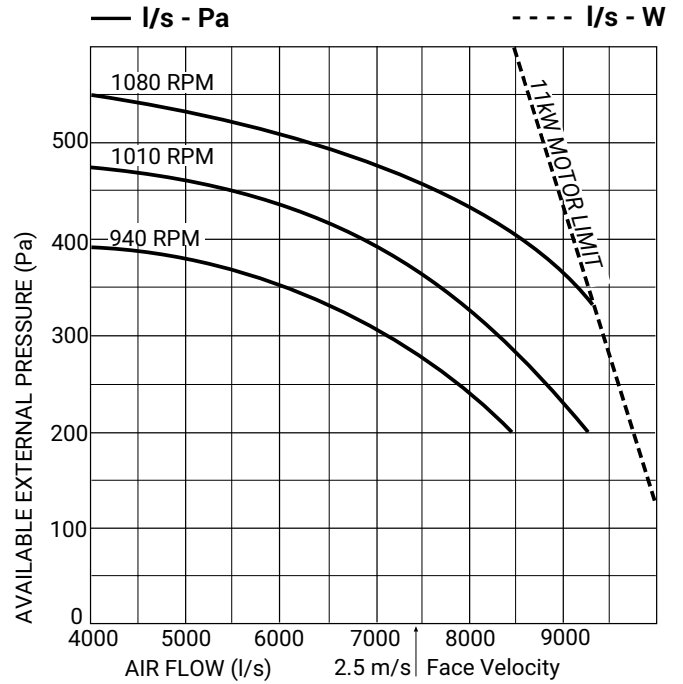

Dimensions

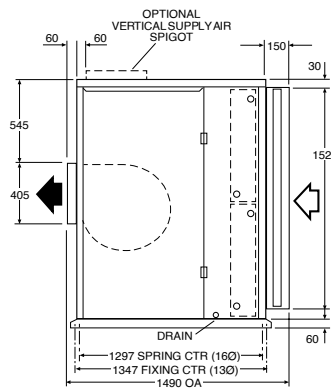
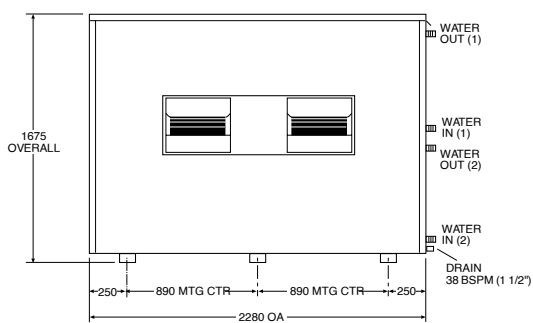
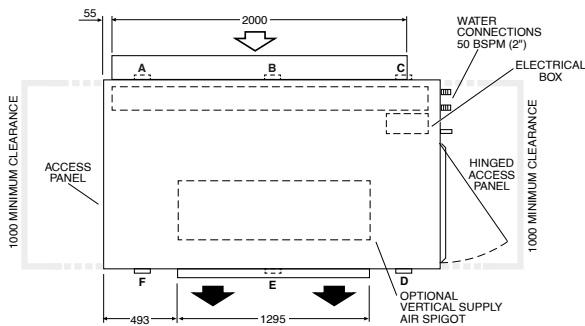

Point Loads					
A	B	C	D	E	F
117	133	149	102	86	70

*4/1 row coil including water

Sound Levels

Test Conditions: BS 848 PT2 1985
Installation Type A (free inlet and outlet)
Direct method of measurement (reverberant room)
Measured in decibels re 1 picowatt

Fan Speed	Sound Power Levels (SWL) (dB)						
	dB(A)	Octave Band Centre Frequency (Hz)					
		125	250	500	1K	2K	4K
940	83	88	86	80	78	74	70
1010	89	92	91	82	81	84	80
1080	99	97	96	95	95	94	90

IJD 2400

			Low Air flow (approx 1.5m/s)						Nominal Air flow (approx 2.5m/s)					
4 row chilled water coil			5000 L/s						9000 L/s					
Air on DB/WB	W. flow L/s	P.D. kPa	Entering water temp						Entering water temp					
			6		7		8		6		7		8	
			T kW	S kW	T kW	S kW	T kW	S kW	T kW	S kW	T kW	S kW	T kW	S kW
23/17	5.0	9.8	106.4	75.4	97.8	71.7	88.7	67.8	139.7	110.5	128.4	105.7	116.8	101.3
	7.0	18.3	115.3	79.4	106.0	75.2	96.4	71.0	159.1	118.5	146.8	113.1	132.7	107.6
	9.0	28.5	121.3	82.1	111.5	77.7	101.5	73.3	172.8	124.3	158.8	118.4	143.8	112.4
27/19	5.0	9.8	130.5	93.4	121.8	89.7	112.7	86.0	170.9	137.6	159.4	133.1	147.6	128.6
	7.0	18.3	141.6	98.2	132.1	94.0	122.3	89.9	194.7	147.0	181.4	141.6	167.9	136.4
	9.0	28.5	149.2	101.5	139.2	97.1	129.0	92.7	212.0	154.0	197.4	148.1	182.9	142.3
31/21	5.0	9.8	156.4	110.9	147.6	107.3	138.2	103.6	204.1	163.8	191.9	159.4	179.6	154.9
	7.0	18.3	169.8	116.5	160.0	112.4	150.1	108.3	233.2	174.9	219.4	169.6	205.0	164.2
	9.0	28.5	179.3	120.6	168.9	116.2	158.6	111.8	253.6	182.8	238.7	177.0	223.7	171.3
35/24	5.0	9.8	196.9	124.2	187.3	120.6	177.7	117.0	253.3	181.0	240.9	176.8	227.3	172.3
	7.0	18.3	216.1	131.8	206.0	127.8	195.5	123.7	291.4	194.1	277.2	189.1	262.5	184.1
	9.0	28.5	228.0	136.7	217.3	132.3	206.5	127.9	319.8	204.5	304.1	198.8	288.4	193.1
6 row chilled water coil														
23/17	5.0	14.2	120.9	82.9	111.3	78.6	101.5	74.3	163.9	123.1	150.8	117.6	137.2	111.9
	7.0	25.9	129.7	87.0	119.3	82.2	108.8	77.5	185.6	132.3	170.8	126.0	155.7	119.6
	9.0	40.3	135.7	89.8	124.9	84.8	113.9	79.8	200.1	138.7	184.6	131.9	168.0	124.8
27/19	5.0	14.2	148.6	102.6	138.8	98.3	128.8	94.1	200.7	152.8	187.6	147.5	174.3	142.2
	7.0	25.9	159.3	107.5	149.4	103.0	138.8	98.3	227.8	163.9	212.5	157.6	197.5	151.4
	9.0	40.3	166.9	110.9	155.9	105.9	144.7	100.9	246.6	172.1	230.3	165.0	213.7	158.1
31/21	5.0	14.2	178.1	121.8	168.3	117.6	157.9	113.3	240.1	181.7	225.9	176.3	212.3	171.1
	7.0	25.9	192.0	127.9	181.4	123.3	170.6	118.6	272.2	194.5	256.9	188.3	241.1	182.1
	9.0	40.3	200.6	131.9	189.6	126.8	178.0	121.8	295.6	204.1	278.9	197.2	262.0	190.3
35/24	5.0	14.2	225.2	137.5	214.8	133.2	204.2	129.1	297.3	200.9	283.1	195.8	268.9	190.9
	7.0	25.9	243.7	145.3	232.6	140.5	221.4	135.9	341.4	217.2	325.3	211.1	308.9	205.1
	9.0	40.3	255.1	150.3	243.4	145.1	231.6	140.1	371.5	228.8	354.1	222.0	337.0	215.4
1 row hot water coil														
Air on DB	W. flow L/s	P.D. kPa	Entering water temp			Entering water temp								
			50	65	80	50	65	80						
7	4.0	8.6	116.4	156.9	197.6	159.0	226.0	270.2						
	6.0	17.8	123.3	166.4	209.2	173.0	245.4	293.8						
	8.0	29.6	129.1	174.0	218.9	183.1	259.4	310.7						
15	4.0	8.6	94.1	134.5	174.9	128.9	184.2	239.4						
	6.0	17.8	99.7	142.6	185.2	140.1	200.2	260.3						
	8.0	29.6	104.3	148.8	193.7	148.5	211.9	275.4						
21	4.0	8.6	77.7	118.0	158.1	106.5	161.5	216.4						
	6.0	17.8	82.3	124.8	167.4	115.7	175.5	235.3						
	8.0	29.6	86.0	130.4	174.7	122.4	185.7	249.0						

Performance Data

IJD 2400

Air Handling

Notes:

1. Air flows given are for a unit with no filter installed.
2. In a free blown application, beware of exceeding indoor fan motor's full load amp limit.
3. Airflows are for dry coil. Reduce airflow by 10% in high moisture removal conditions. Refer to page 70 for filter pressure drop.

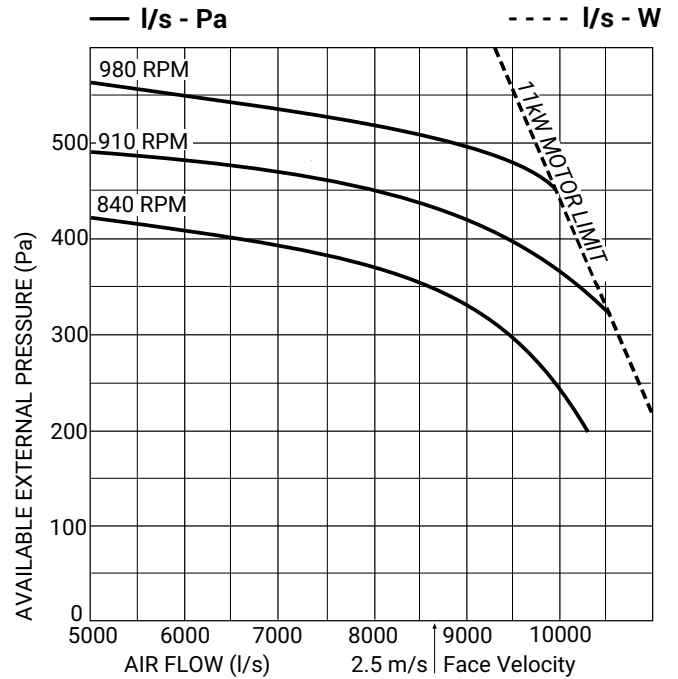

Dimensions

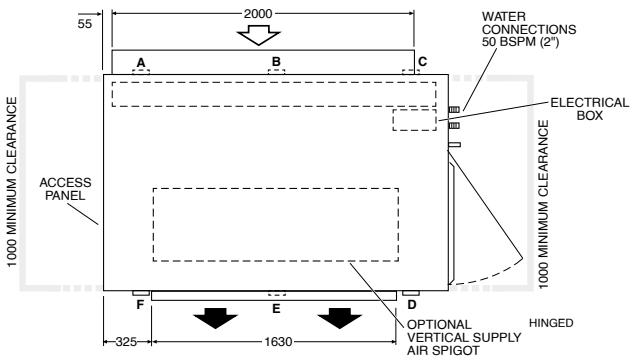

Point Loads					
A	B	C	D	E	F
144	163	184	125	106	87

*4/1 row coil including water

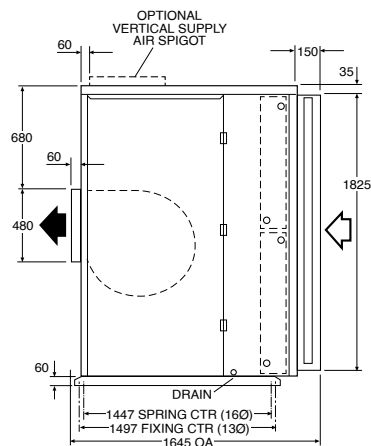
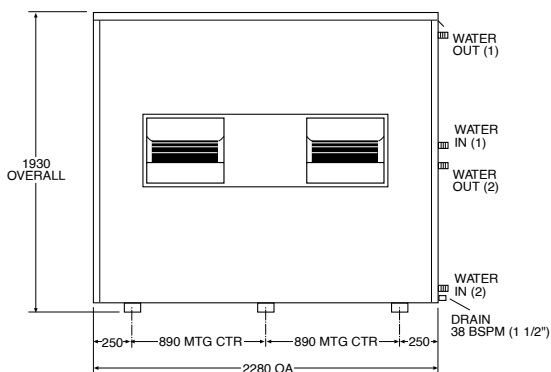

Sound Levels

Test Conditions: BS 848 PT2 1985
 Installation Type A (free inlet and outlet)
 Direct method of measurement (reverberant room)
 Measured in decibels re 1 picowatt

Fan Speed	Sound Power Levels (SWL) (dB)						
	dB(A)	Octave Band Centre Frequency (Hz)					
		125	250	500	1K	2K	4K
840	83	86	83	80	77	76	72
910	90	91	88	87	86	84	79
980	97	97	94	92	92	92	88

Range Options & Features

The available Temperzone options allows you to completely customise your unit, giving you flexibility and ultimate control.

Model	GMW	MKT	IMDL	IMDL-Y	IXDL	IMD	IMD-Y	IJD
FEATURES								
kW Range (kW)*	4.0 - 16.0	2.0-11.0	5.0-15.5	5.0-15.5	4.0 - 20.0	9.5 - 55.0	9.5 - 55.0	36.0 - 230.0
EC Fan (Y) version	-	-	-	●	●	-	●	□
0-10V Fan Speed Control	-	-	-	●	●	-	●	□
3rd Party Controls Input	●	●	●	●	●	●	●	●
High Static Fans	-	-	-	-	-	●	●	●
Epoxy Coated Coil								
Chilled Water Cooling	●	●	●	●	●	●	●	●
Hot Water Heating (STD)	●	●	●	●	●	●	●	●
Alternative Electric Heating	-	-	□	□	-	□	□	□
Cabinet Colour	●	-	-	-	-	□	□	□
Stainless Steel Cabinet	-	-	-	-	-	□	□	□
Configuration Options								
Standard Handing (RHS)	-	●	●	●	●	●	●	●
Opposite Handing (LHS)	-	●	●	●	□	●	●	□
Vertical Air Discharge	-	-	-	-	-	-	-	□
Accessories								
Washable Screen Filter	●	-	-	-	-	-	-	-
12mm (Washable)	-	□	●	●	●	□	□	-
50mm (Disposable)	-	-	-	-	-	-	-	□
Spring Hanger Kit	-	-	-	-	-	□	□	-
Multi-Oval Spigot	-	-	□	□	●	-	-	-

● Standard

□ Option

- Not Applicable

* Nominal cooling capacity @ nominal air flow, 27/19 entering air, 7.0°C water.





Temperzone Fan Coil Selection Program

Temperzone offers a comprehensive web based Fan Coil Unit Selection Program. With the ability to set all relevant parameters, including water flow rate, you will instantly select the required fan coil units for your project.

The Fan Coil Selection program can be found at www.temperzone.biz

If you need assistance with your selections call your local temperzone office for help.

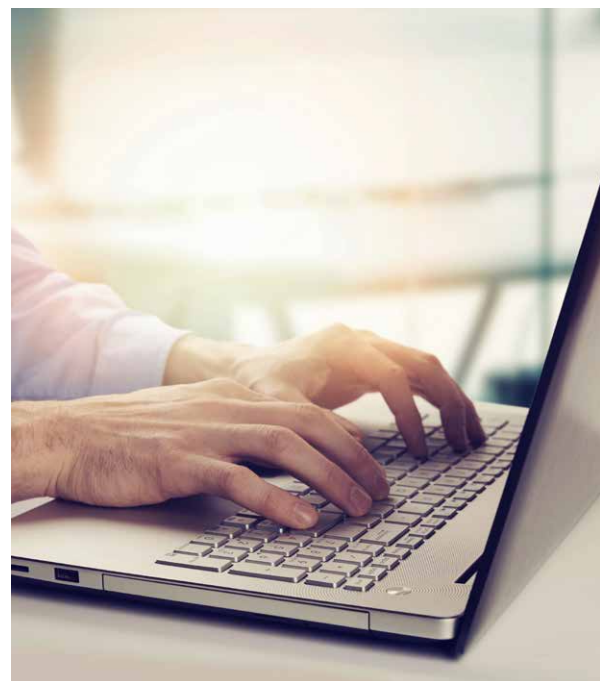



Temperzone Customer Care

Temperzone Customer Care is designed to deliver the highest level of support and accessibility to all our customers. This program provides factory trained technicians with the ability to resolve issues on-site, significantly reducing guesswork from commissioning.

With Temperzone products continually evolving to provide higher levels of efficiency, control and protection we want our customers to have the comfort of knowledge that Temperzone will be there right along-side them for the entire product life cycle.

Temperzone offers a wide range of training courses in application, service and commissioning.

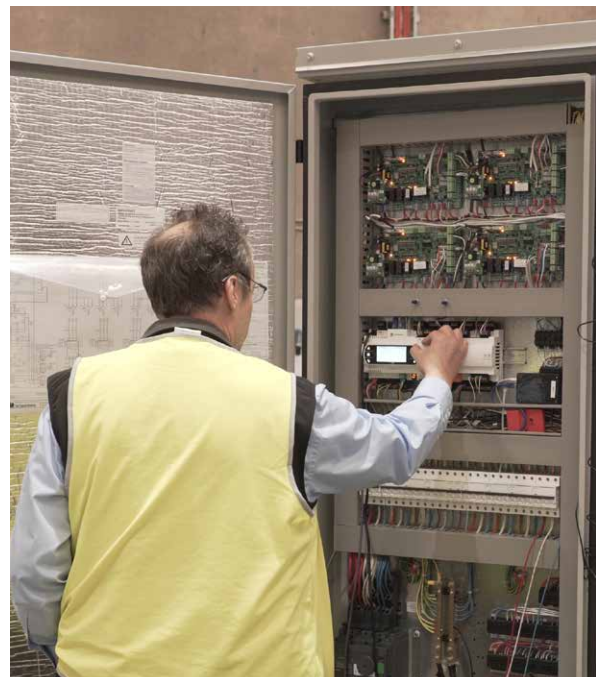

Temperzone Australia Pty Ltd

ENQUIRIES

Australia: sales@temperzone.com.au
New Zealand: nzsales@temperzone.com
Singapore: sales@temperzone.com.sg

AUSTRALIA

Sydney: (02) 8822 5700
Adelaide: (08) 8115 2111
Brisbane: (07) 3308 8333
Melbourne: (03) 8769 7600

DISTRIBUTORS

Newcastle: (02) 4962 1155
Perth: (08) 6399 5900
Launceston: (03) 6331 4209

NEW ZEALAND

Auckland: (09) 279 5250
Hamilton: (07) 839 2705
Wellington: (04) 569 3262
Christchurch: (03) 379 3216

ASIA

Singapore: (65) 6733 4292
Shanghai: (21) 5648 2078

temperzone.com
temperzone.biz

