



# **UNIT CONTROLLER 7 (UC7) Operation & Installation**

## **Air-to-Air Units**

**Date:** 20 March 2015

**Issue:** 9

## Contents

1. Connections, air-to-air unit .....	3
2. Functions assigned to SSR1, SSR2 and AUX .....	3
3. Input and output signals .....	4
3.1. Temperature sensor inputs .....	4
3.2. Pressure transducers:.....	4
3.3. Switch input IN #1 .....	4
3.4. Switch input IN #2.....	4
3.5. Remote On/Off .....	4
3.6. Switched signal type thermostats.....	5
3.7. Digitally communicating thermostat .....	6
3.8. Electronic expansion valves.....	7
3.9. DRED inputs.....	7
3.10. Mains power.....	7
3.11. Optional 0-10V analogue input.....	8
4. DIP switch selections .....	9
5. Test mode .....	11
6. Commissioning mode.....	11
7. Set-up mode.....	12
8. Quiet Mode.....	12
8.1. Enabling quiet mode on units with TZT-100 thermostat.....	12
8.2. Enabling quiet mode on units without TZT-100 thermostat.....	12
9. Dry mode (de-humidification) .....	13
9.1. Enabling the TZT-100 thermostat for dry mode.....	14
9.2. Enabling dry mode on units without TZT-100 thermostat .....	14
9.3. Conventional dry mode.....	14
9.4. Advanced dry mode .....	15
9.5. Super dry mode.....	15
10. De-icing the outdoor coil.....	15
11. Units with more than one UC7.....	16
12. Control by BMS and data logging .....	16
13. Display messages (normal operation) .....	16
14. Faults .....	17
15. Specifications .....	19

**Note:**

**The information in this document applies to UC7 controllers programmed with software version 4.91 or later.**

To find the UC7 software version:

- Turn on mains power to the UC7 controller and observe the display.
- First the display will show the characters “UC7”, followed by the software version.

**1. Connections, air-to-air unit**

The drawing below shows all possible connections for air-to-air units. Most units do not require the use of all input /output signals.

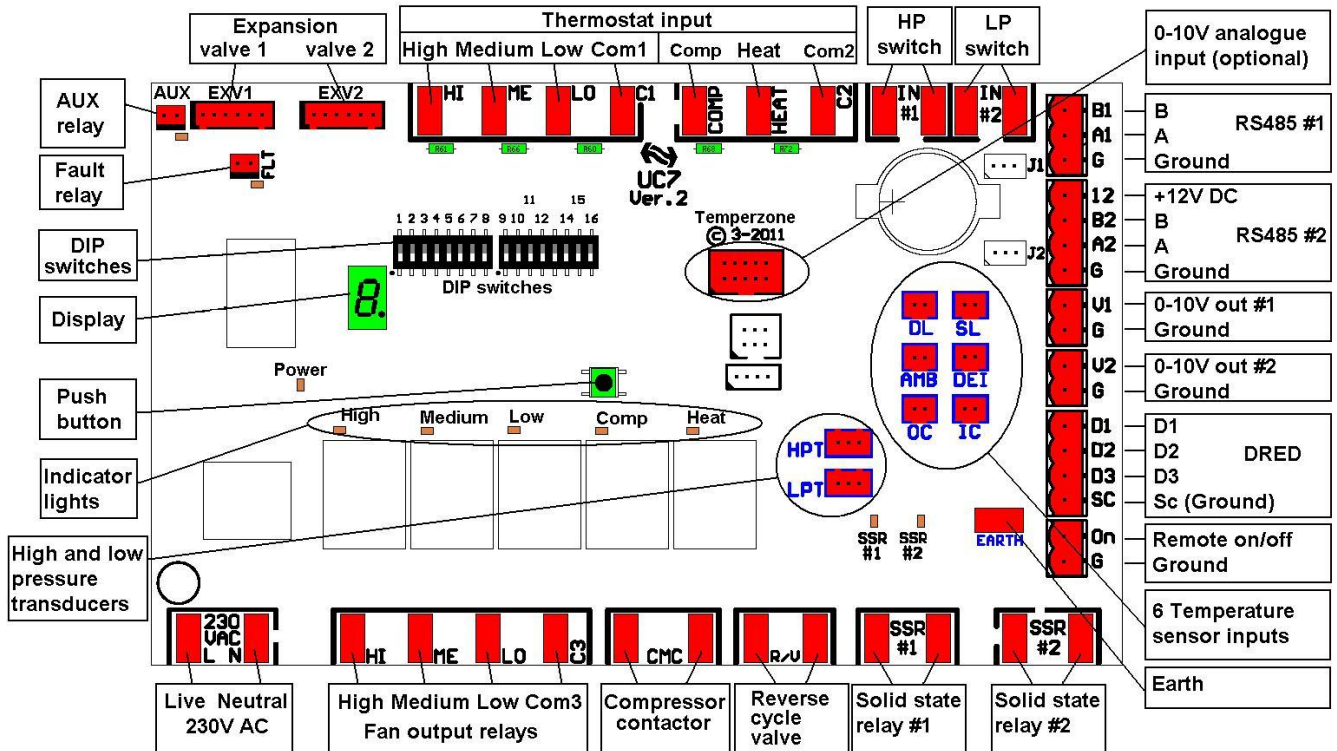

**2. Functions assigned to SSR1, SSR2 and AUX**

System	Digital	Tandem	SSR1	SSR2	AUX	Notes
Air to air			CCH	-	ECO/-	* See notes
	•		CCH	CAP	ECO/-	* See notes
		•	CMC2	CCH	ECO/-	* See notes
	•	•	CMC2	CAP	ECO/CCH	* See notes

Legend:

- CCH = Crank case heater
- CAP = Capacity solenoid (digital scroll compressor)
- CMC2 = Compressor 2 contactor (tandem system)
- ECO = Economiser

\* Notes:

The economiser output is enabled only with DIP switch 13 OFF and DIP switch 15 ON.

If the economiser function is enabled on a tandem air-to-air unit with a digital compressor the AUX output functions as economiser output. In such units the UC7 does not provide an output for a crank case heater. If switch 15 is OFF the AUX output can be used to control a crank case heater.

In all other cases the AUX output on an air-to-air unit has no function and will be off.

### 3. Input and output signals

#### 3.1. Temperature sensor inputs

**Note:**

If pressure transducers are connected to the HPT and LPT inputs then there is no need for temperature sensors on the outdoor coil and indoor coil (OC and IC).

Connector	Function	Notes
DL	Compressor discharge line	Red
SL	Compressor suction line	Blue
AMB	Ambient	Yellow or black (not always required)
DEI	De-Ice (on fins of outdoor coil)	Blue (not required on cooling only units)
OC	Outdoor coil	Yellow (not always required)
IC	Indoor coil	Yellow (not always required)

#### 3.2. Pressure transducers:

Connector	Function	Default pressure range	Output voltage
HPT	High pressure	0 to 4500kPa	0.5 to 4.5V
LPT	Low pressure	0 to 1730kPa (fixed capacity compressors) 0 to 3450kPa (digital scroll compressors)	0.5 to 4.5V

Not all temperzone air conditioning units are equipped with pressure transducers. If no pressure transducer is present then the corresponding switch input (IN#1 and/or IN#2) is configured as an input for a pressure switch. Refer to sections 3.3 and 3.4.

#### 3.3. Switch input IN #1

If the unit has a high pressure transducer connected to HPT then no high pressure switch is needed and the IN #1 terminals can be left un-connected.

If a high pressure switch is fitted then connect it directly to the two IN #1 terminals.

#### 3.4. Switch input IN #2

Low pressure transducer	LP switch	Overload switch	What to do with the IN #2 terminals
Yes	No	No	Short IN #2 terminals together.
Yes	No	Yes	Connect overload switches in series, then to the IN #2 terminals.
No	Yes	No	Connect low pressure switch directly to the two IN #2 terminals.

#### 3.5. Remote On/Off

A remote On/Off signal ('dry' or 'voltage-free' contacts) can be connected to the "On" and "G" terminals.

To turn the unit **on** the remote on/off input must be **closed-circuit**.

If no remote On/Off function is needed then the terminals must be connected (looped).

When the unit is off by the remote on/off signal the display will show a slowly flashing – symbol.

### 3.6. Switched signal type thermostats

Signals from a thermostat that provides switched signals normally connect to the following input signals:

- COMP
- HEAT (not required for cooling-only installations)
- HIGH – MEDIUM – LOW (required only when the UC7 controls the indoor fan)

If a communicating thermostat is used (TZT-100), or the unit is controlled by a BMS via Modbus over RS485, or the UC7 is configured as a slave unit, then terminals HEAT, HI, ME, LO, C1, C2 can be left unconnected.

If the UC7 is configured as a slave unit AND the master unit is controlled by BMS via Modbus over RS485, or a TZT-100 thermostat is used, then the slave COMP input acts as an input for overload switches. If no overload switches are to be connected then the COMP input should be made permanently active with 24V AC or 230V AC.

If the master uses the switched signal type COMP input then each slave unit must also have an appropriate COMP input signal connected.

**Important note for version 3 boards (part number 201 000 403):**

UC7 version 3 boards will accept 24V AC or 12V DC control signals on inputs HI, ME, LO, COMP and HEAT. These boards **cannot** accept 230V AC control signals!

**Important note for version 2 boards (part number 201 000 390):**

A new UC7 version 2 board accepts 24V (AC or DC) signals from the thermostat.

It is allowed to connect 230V AC signals to inputs HI, ME, LO, COMP and HEAT. When 230V AC is applied for the first time to any one of these inputs a small puff of smoke may come from resistors R61, R56, R50, R68 or R72. **This is normal and will occur only once!**

(These five resistors are special fusible types, designed for this purpose.)

**Once 230V AC has been applied to any of these inputs, they will no longer respond to 24V AC signals!**

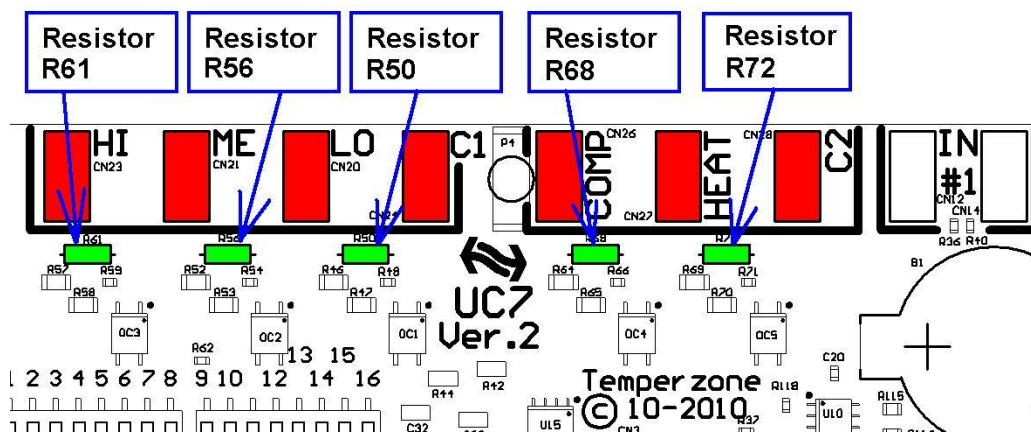

Signal level:	Terminals “C1” and “C2” must connect to:
24V AC or DC	24V common
230V AC	Mains neutral

The UC7 provides 12V DC power on terminal “12” that can be used to power a thermostat. Terminal “G” is the ground return for the 12V DC power.

### 3.7. Digitally communicating thermostat

Use shielded twisted pair suitable for RS485 to connect a digitally communicating thermostat. The UC7 supports the Temperzone TZT-100 thermostat. Other thermostats can be added on request.

Connect the twisted pair wires to terminals “B2” (-) and “A2” (+).

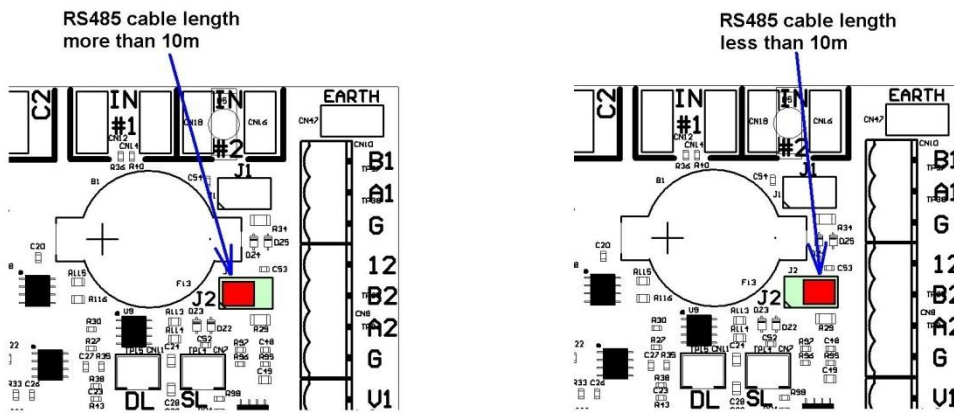

If the distance between the thermostat and the UC7 is greater than 10m and the UC7 is located at one end of the cable then place jumper “J2” on the centre and left pins

Otherwise place jumper “J2” on the centre and right pins.

The UC7 provides 12V DC power on terminal “12” that may be used to power the thermostat. Terminal “G” is ground return for the 12V DC power. For this application it is recommended to use a shielded cable with twisted pairs. The correct connections are shown here:

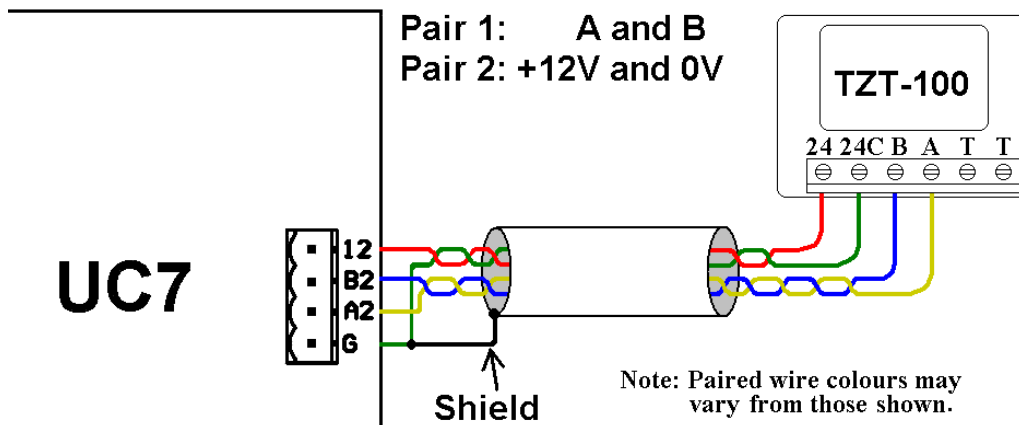

The TZT-100 thermostat can also be powered by an **isolated** 24V AC power source as shown below:

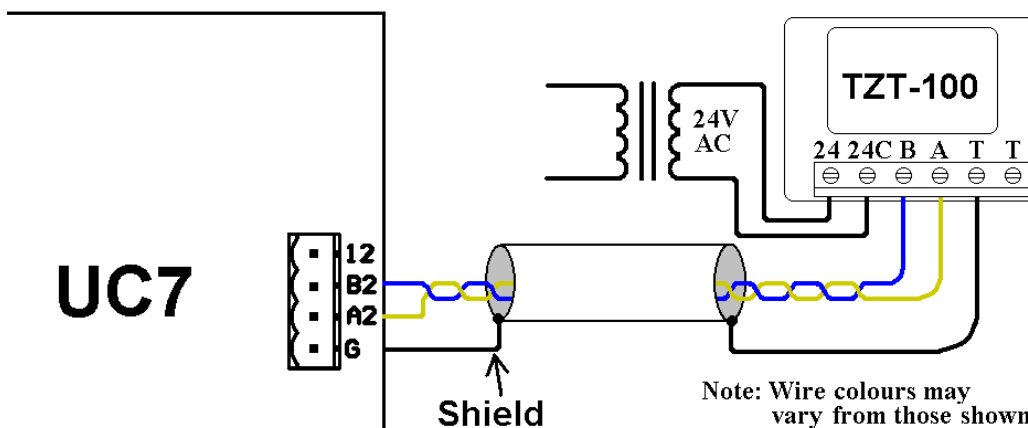

In this case the 24V AC supply common should NOT be earthed elsewhere in the system, otherwise differences in earth potentials can lead to unreliable communications between the thermostat and the UC7.

### 3.8. Electronic expansion valves

The UC7 can control up to two electronic expansion valves (EXV) via connectors EXV1 and EXV2. The expansion valves must be 12V unipolar types. The connectors must be compatible with JST type XH and have either 5 pins or 6 pins. If the valve connectors have 5 pins then use a small sharp knife to (very carefully!) make a cut in the white plastic of the headers about 2mm beside the leftmost slot, then insert the connector so that pin 1 (leftmost) remains unconnected.

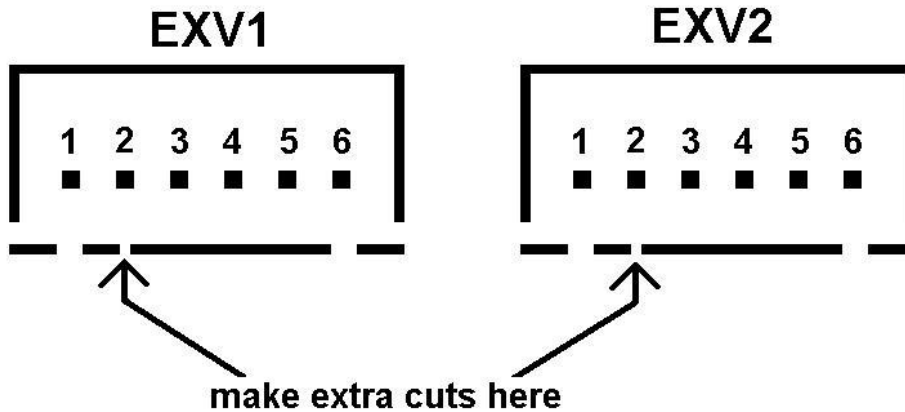

DIP switches 7 and 8 on UC7 board define how the outputs EXV1 and EXV2 are operated. Refer to section 4 (DIP switch selections) for more details.

### 3.9. DRED inputs

- Inputs D1, D2 and D3 can be connected to a set of three 'voltage free' dry switch contacts in accordance with the DRED standard. The SC terminal is the common for the three inputs.

*Note: Terminal SC is internally directly connected to 'G' and 'EARTH'.*

- Optionally, the DRED level can be communicated to the UC7 by a BMS via RS485 serial communications. If this option is used then it is not necessary to connect anything to the DRED inputs; the inputs can be left open circuit.
- If the DRED function is not required then leave these contacts open circuit.
- Input D1 alternate function: Quiet Mode enable/disable. Refer to Quiet Mode and the DIP switch settings for more information.
- Input D2 alternate function: Dry Mode enable/disable. Refer to Dry Mode and the DIP switch settings for more information.

### 3.10. Mains power

Connect 230V AC mains live to terminal **L**, neutral to terminal **N**.

**NOTE:**

*The **EARTH** terminal on the UC7 controller board **MUST** always be directly connected to the unit earth stud.*

### 3.11. Optional 0-10V analogue input

Units equipped with a digital scroll compressor are capable of variable duty. The required duty can be set in three ways:

- Automatic, only in combination with the TZT-100 thermostat
- Via Modbus, for example by a BMS
- Via an optional 0-10V analogue input

The 0-10V input comes as a small plug-in-board and connects directly to the UC7 controller via the 10-pin header pins on the circuit board. The controller automatically detects the presence of the 0-10V input board when power is applied.

Note: The 0-10V input is not electrically isolated; the terminal “G” is directly connected to the controller EARTH terminal. If the 0-10V signal source is located remotely from the unit then it is recommended to use a suitable 0-10V isolating amplifier.

**IMPORTANT:** The 0-10V plug-in board must be connected to the controller in the correct orientation!

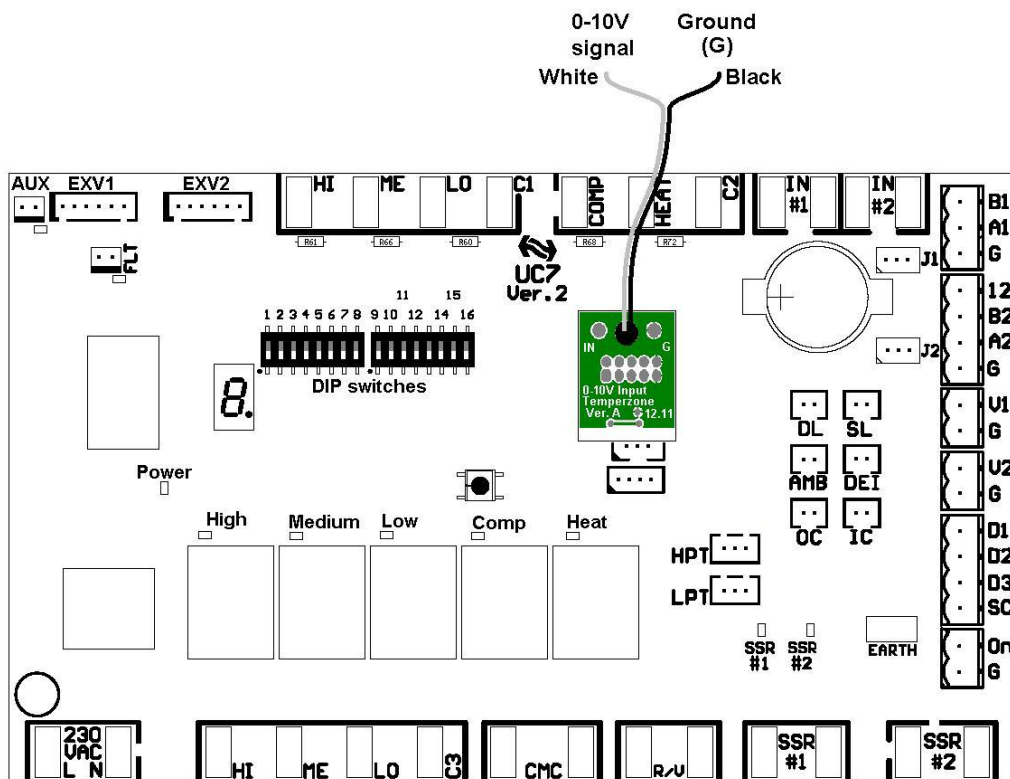



## 4. DIP switch selections

Table 1, DIP switch functions for switches 1 to 13.

Switch		Function
<b>1</b>		<b>Indoor air flow (also refer to chapter 9: Dry mode)</b>
<b>OFF</b>		Variable indoor air flow: Indoor fan performs a warm start when unit starts heating. Indoor fan stops during de-ice cycles. Indoor fan speed may vary from thermostat request.
<b>ON</b>		Fixed indoor air flow: Indoor fan follows thermostat request even when heating starts. Indoor fan continues during de-ice cycles. Indoor fan speed follows thermostat request.
<b>2</b>		<b>Compressor type</b>
<b>OFF</b>		Fixed capacity.
<b>ON</b>		Digital scroll.
<b>3</b>	<b>4</b>	<b>Outdoor fan selection</b>
<b>OFF</b>	<b>OFF</b>	Three speed fan (HI/ME/LO relay outputs).
<b>ON</b>	<b>OFF</b>	One speed fan (HI relay output).
<b>OFF</b>	<b>ON</b>	0-10V EC fan (V1 output).
<b>ON</b>	<b>ON</b>	Modbus over RS485 EC fan (A2 and B2 outputs).
<b>5</b>	<b>6</b>	<b>Indoor fan selection</b>
<b>OFF</b>	<b>OFF</b>	Three speed fan (HI/ME/LO relay outputs).
<b>ON</b>	<b>OFF</b>	One speed fan (ME relay output).
<b>OFF</b>	<b>ON</b>	0-10V EC fan (V2 output). <b>Select this option when the UC7 does not control the indoor fan.</b>
<b>ON</b>	<b>ON</b>	Modbus over RS485 EC fan (A2 and B2 outputs).
<b>7</b>	<b>8</b>	<b>Electronic expansion valve operating mode</b>
<b>OFF</b>	<b>OFF</b>	No electronic expansion valves (e.g. accurators, capillary tube).
<b>ON</b>	<b>OFF</b>	One valve or two parallel electronic expansion valves (as required), positions always identical. If the unit is capable of advanced dry mode operation then this setting is the 'High Efficiency Mode'.
<b>OFF</b>	<b>ON</b>	Two electronic expansion valves:      Cooling: EXV1 regulates, EXV2 fully open Heating: EXV1 fully open, EXV2 regulates  (This option should also be selected if the UC7 controls an outdoor or an indoor unit only. Use EXV1 output for an indoor unit, EXV2 output for an outdoor unit.)
<b>ON</b>	<b>ON</b>	Advanced Dry Mode. This option must only be selected on units suitably equipped. Dry mode has no influence on the unit when heating.

<b>9</b>	<b>10</b>	<b>Electronic expansion valve type</b>	<b>How to recognise the valve type</b>
<b>OFF</b>	<b>OFF</b>	Dunan DPF series	removable black coil
<b>ON</b>	<b>OFF</b>	Zhe Jiang Sanhua DPF series	non-removable metal coil
<b>OFF</b>	<b>ON</b>	Carel E2V series (& E3V series with unipolar coil)	removable red coil
<b>ON</b>	<b>ON</b>	Custom series	-
<b>11</b>	<b>12</b>	<b>System number (for units with multiple compressors)</b>	
<b>OFF</b>	<b>OFF</b>	1 (master system, select this for single compressor units)	
<b>ON</b>	<b>OFF</b>	2 (slave system)	
<b>OFF</b>	<b>ON</b>	3 (slave system)	
<b>ON</b>	<b>ON</b>	4 (slave system)	
<b>13</b>	<b>Function of DIP switches 14, 15 and 16</b>		
<b>OFF</b>	Standard DIP switch functions; refer to table 2.		
<b>ON</b>	Custom DIP switch functions; refer to table 3.		

Table 2, Standard DIP switch functions for switches 14, 15 and 16.

Switch		Function
<b>13</b>	<b>14</b>	<b>Tandem compressor option</b>
<b>OFF</b>	<b>OFF</b>	Single stage system.
<b>OFF</b>	<b>ON</b>	Tandem compressor system.
	<b>15</b>	<b>Economizer option</b>
<b>OFF</b>	<b>OFF</b>	Disabled
<b>OFF</b>	<b>ON</b>	Enabled (AUX output)
	<b>16</b>	<b>Quiet mode option</b>
<b>OFF</b>	<b>OFF</b>	Disabled
<b>OFF</b>	<b>ON</b>	Enabled (D1 input)

Table 3, Custom DIP switch functions for switches 14, 15 and 16.

Switch				Function
<b>13</b>	<b>14</b>	<b>15</b>	<b>16</b>	<b>Custom options</b>
<b>ON</b>	<b>OFF</b>	<b>ON</b>	<b>ON</b>	Enable all of the following options: Quiet mode (D1 input) Dry mode (D2 input) Economiser (AUX output)  <b>All other custom configuration options for air-to-air units are reserved and must not be selected.</b>

## 5. Test mode

To activate test mode follow these steps:

- Apply power to the unit and wait until the power-on sequence is successfully completed.
- Ensure the thermostat is 'OFF' (COMP and HEAT signals must be OFF).
- Press and hold the push button (2 to 4 seconds) until the display shows the letter 't', then release the button.

Test mode will start immediately. The following outputs are activated one by one in the following order, for a duration of 4 seconds each and with a pause between each output:

- R/V
- Outdoor fan low - medium - high
- Indoor fan low - medium - high
- SSR1
- SSR2
- AUX
- CMC

If the unit has high and low pressure transducers then the pressure readings from the two sensors is compared before the CMC output is activated. The two pressure readings are expected to be approximately equal. If the two pressure readings are found to be very different then fault F34 will be reported. The pressure comparison is then repeated every 60 seconds and the fault is cleared as soon as the pressures have equalised sufficiently.

When the test sequence is complete the UC7 returns to normal mode and the display will show a blinking decimal point.

## 6. Commissioning mode

To activate commissioning mode follow these steps:

- Apply power to the unit and wait until the power-on sequence is successfully completed.
- Ensure the thermostat is 'OFF' (COMP and HEAT signals must be OFF).
- Press and hold the UC7 push button (6 to 8 seconds) until the display shows the letter 'c', then release the button.

Commissioning mode will start immediately and end after 30 minutes. When the 30 minutes have expired the UC7 automatically returns to normal mode. During commissioning mode some safety times are reduced to:

- Minimum On-Off time ('Run'-time): 10 seconds
- Minimum Off-On time ('Off'-time): 20 seconds
- Minimum On-On time: 30 seconds
- Heat/cool change-over time: 40 seconds
- De-ice mode hold-off time 60 seconds

## 7. Set-up mode

In setup mode it is possible to change the modbus address of the UC7 controller. The default modbus address of the temperzone UC7 controller is **44**. The procedure to change the address is as follows:

- Turn mains power on.
- Ensure the thermostat and the compressor are off.
- Press and hold the pushbutton on the controller board until the display shows the letter “S”, then release the button. The controller is now in “setup” mode.
- The display will show the modbus device address. Subsequent button presses will increase the address. After address 99 the address will cycle back to 1 in round-robin fashion.
- When the button has not been pressed for more than 30 seconds the controller will leave setup mode and return to normal mode.

NOTE: If the address was changed then the controller will save a new address in non-volatile memory (i.e. the new address will be retained even after mains power has been switched off).

## 8. Quiet Mode

Quiet mode can reduce the amount of noise produced by the outdoor fan. Quiet mode is available both when cooling and when heating.

The effectiveness of Quiet mode depends on the outdoor ambient temperature. The limitations are:

- If the unit is heating while the outdoor ambient temperature is below about +5°C then selecting Quiet mode will have no effect.
- If the unit is cooling while the outdoor ambient temperature is above about +40°C then Quiet mode will also have no effect.

### 8.1. Enabling quiet mode on units with TZT-100 thermostat

**Note:** This option is available only on TZT-100 thermostats with software version 2.31 or later. If the TZT-100 thermostat is programmed with an earlier software version then refer to paragraph 8.2 to enable Quiet mode using input D1.

To select Quiet mode press-and-hold down the MODE button for 3 seconds until the AUX symbol appears on the display of the thermostat. To switch Quiet mode off do the same until the AUX symbol disappears.

### 8.2. Enabling quiet mode on units without TZT-100 thermostat

A unit operating without TZT-100 thermostat, or a unit with a TZT-100 thermostat that is programmed with an older software version, can be configured for Quiet mode operation as follows:

	DIP switches				Notes
	13	14	15	16	
Option 1	Off	-	-	On	-
Option 2	On	Off	On	On	Also makes Dry mode(s) available

Both sets of DIP switches settings shown above reserve input D1 as an enable/disable signal to start or stop operation in Quiet mode. Input D1 is then not available for the DRED function.

To start or stop Quiet mode via input D1:

- D1 input open circuit: Quiet mode OFF
- D1 input shorted to terminal SC (same as ground or G): Quiet mode ON

## 9. Dry mode (de-humidification)

The UC7 controller can offer a variety of options while cooling the room:

Mode	Available on	Indoor fan speed
Standard cooling	All units	Fixed
High-efficiency cooling	All units	Variable and must be controlled via the UC7
Conventional dry cooling	All units	Variable and must be controlled via the UC7
Advanced dry cooling	Units with dual expansion valves and split indoor coil	Fixed
Super-dry cooling	Units with dual expansion valves and split indoor coil	Variable and must be controlled via the UC7

- **Standard cooling mode:**

This is the default mode for Temperzone units with UC7 controller when no other cooling mode is activated. In this mode the unit does not actively control the indoor coil temperature. The supply air is de-humidified only when the indoor coil temperature remains below the dew point. The indoor fan speed is equal to the speed requested by the thermostat.

Standard cooling mode is suitable for installations where indoor airflow must remain constant and where de-humidification is less important.

- **High efficiency cooling mode:**

The UC7 controller must be allowed to vary the indoor fan speed to obtain an indoor coil temperature for optimum unit duty and efficiency. Thus the indoor fan speed can be different from the speed as requested by the thermostat. The supply air is de-humidified only when the indoor coil temperature remains below the dew point.

High efficiency cooling mode may be unsuitable for installations where indoor airflow must remain constant.

- **Conventional dry cooling mode:**

The UC7 controller must be allowed to vary the indoor fan speed to obtain a low indoor coil temperature to provide de-humidification of the supply air. Thus the indoor fan speed can be different from the speed as requested by the thermostat.

Conventional dry cooling mode may be unsuitable for installations where indoor airflow must remain constant.

- **Advanced dry cooling mode:**

Advanced dry mode provides highly effective de-humidification over a wide range of operating conditions and unit duty whilst the indoor fan speed remains unaffected. De-humidification of the supply air is achieved by operation of dual electronic expansion valves.

Advanced dry cooling mode is suitable for installations where indoor airflow must remain constant.

- **Super dry cooling mode:**

Super dry cooling mode is a combination of advanced dry mode and conventional dry mode.

The UC7 controller must be allowed to vary the indoor fan speed. Under most operating conditions the indoor fan speed will remain equal to the speed as requested by the thermostat. Only when the desired indoor coil temperature cannot be achieved by the dual electronic expansion valves alone then the controller will adjust the indoor fan speed to obtain maximum de-humidification.

Super dry cooling mode may be unsuitable for installations where indoor airflow must remain constant.

### 9.1. Enabling the TZT-100 thermostat for dry mode

**Note:** This option is available only on TZT-100 thermostats with software version 2.31 or later. If the TZT-100 thermostat is programmed with an earlier software version then refer to paragraph 9.2 to enable Dry mode using input D2.

To configure the TZT-100 thermostat for dry mode:

- Press-and-hold the O/RIDE button for 15 seconds until the PIN code is shown (88:15).
- Use the Up/Down buttons to select the correct PIN code (default is 88:21), then press O/RIDE again. The thermostat is now in installer mode.
- Press O/RIDE a number of times until the screen shows Fn.
- Press the Up/Down buttons to select the correct option. The options are:
  - -- manually select heating / cooling
  - H heating only
  - C cooling only
  - A heating / cooling / auto
  - d- manually select heating / cooling / cooling with dry mode
  - dC cooling / cooling with dry mode
  - dA heating only / cooling only / cooling with dry mode / auto with dry mode
- After selecting the desired option press MODE to exit from installer mode.

### 9.2. Enabling dry mode on units without TZT-100 thermostat

A unit operating without TZT-100 thermostat, or a unit with a TZT-100 thermostat that is programmed with an older software version, can be configured for Dry mode operation as follows:

DIP switches			
13	14	15	16
On	Off	On	On

The DIP switches setting shown above reserve input D2 as an enable/disable signal to start or stop operation in Dry mode. Input D2 is then not available for the DRED function.

To start or stop Dry mode via input D2:

- D2 input open circuit: Dry mode OFF
- D2 input shorted to terminal SC (same as ground or G): Dry mode ON

### 9.3. Conventional dry mode

Expansion device	DIP switches	
	7	8
Accurators	OFF	OFF
One electronic expansion valve	ON	OFF
Dual electronic expansion valves		

To activate conventional dry mode (refer also to paragraphs 9.1 and 9.2):

- With TZT-100 thermostat: Select cool-dry or cool-heat-dry.  
Fan speed must show Low-Med-High.
- Without TZT-100 thermostat: DIP switch 1 OFF (variable indoor airflow).  
Connect input D2 to SC.

### 9.4. Advanced dry mode

Expansion device	DIP switches	
	7	8
Accurators	Advanced dry mode not available	
One electronic expansion valve		
Dual electronic expansion valves	ON	ON

To activate advanced dry mode (refer also to paragraphs 9.1 and 9.2):

- With TZT-100 thermostat: Select cool-dry or cool-heat-dry.  
Select only one fan speed.
- Without TZT-100 thermostat: DIP switch 1 ON (fixed indoor airflow).  
Connect input D2 to SC.

### 9.5. Super dry mode

Expansion device	DIP switches	
	7	8
Accurators	Super dry mode not available	
One electronic expansion valve		
Dual electronic expansion valves	ON	ON

To activate super dry mode (refer also to paragraphs 9.1 and 9.2):

- With TZT-100 thermostat: Select cool-dry or cool-heat-dry.  
Fan speed must show Low-Med-High.
- Without TZT-100 thermostat: DIP switch 1 OFF (variable indoor airflow).  
Connect input D2 to SC.

## 10. De-icing the outdoor coil

When a unit is in heating mode and the outdoor ambient temperature is low then ice may start to form on the outdoor coil. In such running conditions it is necessary to periodically remove the ice from the outdoor coil. To detect presence of ice on the outdoor coil all Temperzone reverse cycle units have a temperature sensor fitted onto the outdoor coil. Using information from this sensor the logic for de-icing the outdoor coil is as follows:

When the unit is heating and the de-ice sensor reports that the outdoor coil temperature is below +1°C a timer starts counting down from a start value of 35 minutes. When the timer has reached zero then a de-ice cycle is allowed to start but this will happen only if the temperature of the de-ice sensor has reduced further down to -4°C or lower.

The 35 minute duration can become shorter when operating conditions are adverse. The minimum value is 10 minutes, but such a short duration between de-ice cycles would be reached only for the most extreme conditions.

During a de-ice cycle the indoor fan may be stopped to avoid blowing cold air into the room. Whether the indoor fan stops or not is determined by the setting of DIP switch 1 on the UC7 circuit board: OFF means the fan will stop, ON means the indoor fan continues running during the de-ice cycle. If a TZT-100 thermostat is used to control the unit then the UC7 DIP switch setting can be overruled by the selection on the thermostat: AUTO-FAN allows the indoor fan to stop during de-ice, FAN-ON means the indoor fan continues during de-ice mode.

As a de-ice cycle commences initially the compressor will stop while the outdoor fan continues at high speed. After 30 seconds the reverse cycle valve switches over, the outdoor fan stops and the compressor restarts. The outdoor coil will start to warm up causing the ice to melt.

Duration of the de-ice mode is limited a maximum of 10 minutes. De-ice mode normally ends as soon as the de-ice sensor reports a temperature of +12°C or higher. To complete the de-ice cycle the compressor stops once again and the outdoor fan restarts on high speed. This removes melt-water from the outdoor coil so that it does not re-freeze when normal heating mode resumes. The final step of a de-ice cycle is to return the reverse cycle valve to the heating position and restart the compressor.

### 11. Units with more than one UC7

A maximum of up to four UC7 controllers can be connected together in a master-slave arrangement. The connections are shown below.

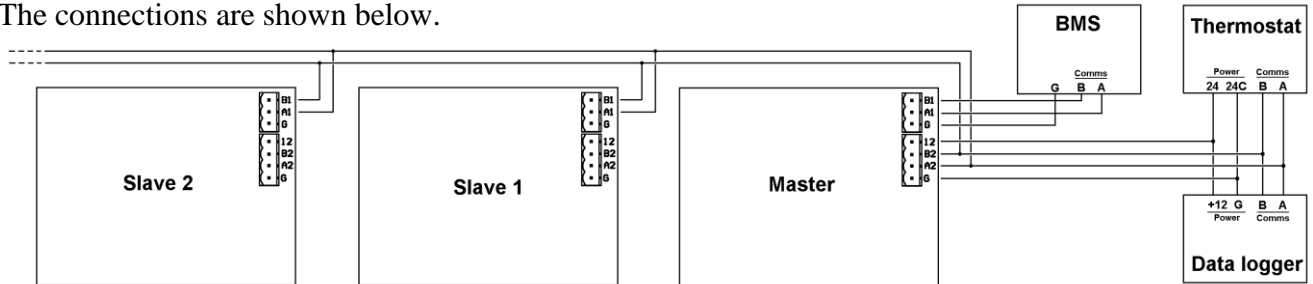

In the arrangement shown above only the master needs to connect to a communicating thermostat. Similarly, a BMS or data logging system also only need to connect to the master.

### 12. Control by BMS and data logging

It is possible to remotely control a unit with one (or more than one) UC7 controller(s), for example by a building management system (BMS). Alternatively, the connections can be used to connect a data logging system. The correct connections are shown above.

Temperzone has available a low cost data logger specifically designed for use with temperzone units. This data logger can be connected as shown above.

For more details about remote control and data logging capabilities refer to documentation titled "*Temperzone UC7 modbus communications*".

### 13. Display messages (normal operation)

The display on the UC7 can show the following messages:

Display	Meaning
UC7 4.91	Name and software version (shown only after power-on)
0 (flashing)	Expansion valves are zeroing (shown only after power-on)
dELAY	The unit waits for a random delay time (up to 30s, occurs only after power-on)
● (flashing)	Ready (normal operation)
— (slowly flashing)	Unit is OFF by Remote On/Off signal
dE-ICE	De-icing the outdoor coil
c	Commissioning mode (lasts for 30 minutes)
t	Test mode (lasts about 1 minute)
HOLD	The compressor is held-on or held-off by a safety timer
dr	DRED energy consumption restriction is active



In addition to the messages shown above, it is possible to use the display to monitor some pressures and temperatures while the unit is in normal mode or in commissioning mode. This is available regardless whether the compressor is on or off.

Repeatedly press the pushbutton to cycle the display through the options (in a round robin fashion). After 2 minutes the display will automatically return to a flashing dot (or “c”).

Button press	Display	Meaning	Units
0	• or c	Normal mode (default)	
1	SLP	Suction line pressure	kPa
2	Et	Evaporating temperature	°C
3	SLt	Suction line temperature	°C
4	SSH	Suction side superheat	K
5	dLP	Discharge line pressure	kPa
6	Ct	Condensing temperature	°C
7	dLt	Discharge line temperature	°C
8	dSH	Discharge side superheat	K
9	• or c	Back to button press 0	

Pressures are shown in kPa. Divide by 6.895 (roughly 7) to convert to PSI.

Temperatures are shown in whole degrees Celsius. If the indicated temperature is below 0°C then a minus sign is shown before the value. If the unit has one or two pressure transducers then the condensing and/or evaporating temperatures shown are converted from pressure readings.

## 14. Faults

Display	Meaning
LP	Low pressure protection is active
HP	High pressure protection is active
HI-t	High temperature protection is active
FROSt	Indoor coil frost protection is active
HI-SL	High suction line temperature protection is active
Lo-dSH	Low discharge superheat protection active
Hi-dSH	High discharge superheat protection active
OL	Overload protection is active “IN #2” input is open circuit <b>or</b> COMP signal is off (for units connected to a TZT-100 thermostat)

<b>Display</b>	<b>Meaning</b>
F10	Outdoor fan fault (no serial communications)
F11	Indoor fan fault (no serial communications)
F12	Low pressure transducer fault (will show as LP)
F13	High pressure transducer fault (will show as HP)
F14	Suction line temperature sensor fault
F15	Discharge line temperature sensor fault
F16	De-Ice temperature sensor fault
F17	Outdoor coil temperature sensor fault
F18	Indoor coil temperature sensor fault
F19	Ambient temperature sensor fault
F20	Superheat is unknown
F21	Thermostat fault (no serial communications)
F22	System 1 or BMS fault (no serial communications)
F23	System 2 fault (no serial communications)
F24	System 3 fault (no serial communications)
F25	System 4 fault (no serial communications)
F26	Invalid DIP switches setting
F27	Invalid fan selection
F28	Invalid economiser selection
F29	Microcontroller temperature exceeds +100 °C
F30	Supply voltage out of bounds (+3.3V DC supply voltage on controller PCB)
F31	A slave unit reports a fault
F32	0-10V input fault
F33	High discharge superheat protection active
F34	Problem with pressure transducer readings
F35	Reverse cycle valve fault
F36	Invalid DIP switch setting on TZT-100 thermostat

## 15. Specifications

*Notes:*

- All input and output signals from/to the UC7 are isolated from the mains inputs (L and N).
- Relay outputs HI, ME, LO, C3, CMC, HEAT, SSR1 and SSR2, as well as inputs HI, ME, LO, C1, COMP, HEAT and C2, are isolated from all other circuits. These inputs and outputs can be connected to external 24V AC or 230V AC live circuits.
- All other input and output signals from/to the UC7 are electrically referenced to the EARTH terminal.
- Any input signal that is referenced to EARTH and that needs to connect to a circuit external to the temperzone unit should be isolated by a suitable means, for example a relay. Typical examples of this are the remote On/Off input, DRED inputs, the IN#1 and IN#2 inputs.
- For safety, and to ensure correct operation of the unit, the EARTH terminal must directly connect to a unit earth stud located close to the controller board.

<b>Mains input</b> L and N	230V AC 50Hz nominal	190V AC minimum	250V AC maximum
<b>Output relays</b> Applies to: HI, ME, LO, CMC and R/V outputs	250V AC, 5A maximum, resistive load 250V AC, 2.5A maximum, inductive load		
<b>Solid state output relays</b> Applies to: SSR1 and SSR2 outputs	12V AC minimum, 250V AC maximum (AC only!) 0.25A maximum (continuous) 2.5A maximum (peak, 0.5s)		
<b>AUX and FLT outputs</b> Designed to operate a relay with 12V DC coil.	Open collector and +12VDC output OFF state: leakage current 0.5mA maximum ON state: 12V DC, 100mA maximum		
<b>EXV1 and EXV2 outputs</b> Designed to operate unipolar electronic expansion valves: 5-wire and 6-wire types.	Open collector and +12VDC output OFF state: leakage current 0.5mA maximum ON state: 12V DC, 275mA maximum per winding		
<b>Isolated inputs</b> Applies to: HI, ME, LO, COMP and HEAT inputs	<b>When configured for 24V input signals:</b> Maximum input voltage OFF state: 3V AC/DC Minimum input voltage ON state: 18V AC/DC Absolute maximum input voltage: 40V AC/DC Input impedance: 4.7kΩ		
	<b>When configured for 230V AC input signals:</b> Maximum input voltage OFF state: 30V AC Minimum input voltage ON state: 180V AC Absolute maximum input voltage: 300V AC Input impedance: 200kΩ		

Continued on the next page.

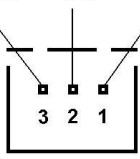
<p><b>IN#1 and IN#2</b>  <b>DRED inputs D1, D2, D3</b>  <b>Remote On/Off input</b></p>	<p>Designed to be operated by isolated voltage free contacts.                  Open circuit voltage: 3.3V DC typical                  Closed circuit current: 3.3mA DC typical</p>
<p><b>V1 and V2 outputs</b></p>	<p>Provide 0-10V DC output.                  Maximum load: 6.5kΩ                  Maximum short circuit output current: 30mA</p>
<p><b>Temperature sensor inputs</b>                  DL: red                  SL, DEI: blue                  AMB: yellow or black                  OC, IC: yellow</p>	<p>Designed to connect to standard Temperzone thermistor temperature sensors.</p>
<p><b>Pressure transducer inputs</b>                  signal +5V 0V</p> 	<p>Power: 5.0V DC, maximum current 50mA                  Signal: 0.5V at the lowest pressure                  4.5V at the highest pressure                  Pressure ranges:                  LPT, unit with a fixed capacity compressor:                  0 to 1730 kPa (0-17.3 bar, 0-251 PSI)                  LPT, unit with a digital scroll compressor:                  0 to 3450 kPa (0-34.5 bar, 0-500 PSI)                  HPT, all units:                  0 to 4500 kPa (0-45.0 bar, 0-653 PSI)</p>
<p><b>Controller working ambient temperature range</b></p>	<p>-10 to +65°C</p>
<p><b>Modbus RS485 serial communications format</b></p>	<p>Baud rate 19200                  Data bits 8                  Parity even                  Stop bits 1</p>